

Honeywell

DCP302
Digital Program Controller
User's Manual

EN1I-6215
Issue 0 (03/99)

SAFETY PRECAUTIONS

■ About Icons

Safety precautions are for ensuring safe and correct use of this product, and for preventing injury to the operator and other people or damage to property. You must observe these safety precautions. The safety precautions described in this manual are indicated by various icons.

The following describes the icons and their meanings. Be sure to read and understand the following descriptions before reading this manual.



WARNING

Warnings are indicated when mishandling this product might result in death or serious injury to the user.







CAUTION

Cautions are indicated when mishandling this product might result in minor injury to the user, or only physical damage to this product.









■ Examples

	<p>Triangles warn the user of a possible danger that may be caused by wrongful operation or misuse of this product.</p> <p>These icons graphically represent the actual danger. (The example on the left warns the user of the danger of electrical shock.)</p>
	<p>White circles with a diagonal bar notify the user that specific actions are prohibited to prevent possible danger.</p> <p>These icons graphically represent the actual prohibited action. (The example on the left notifies the user that disassembly is prohibited.)</p>
	<p>Black filled-in circles instruct the user to carry out a specific obligatory action to prevent possible danger.</p> <p>These icons graphically represent the actual action to be carried out. (The example on the left instructs the user to remove the plug from the outlet.)</p>







WARNING

	Before removing or mounting the DCP302, be sure to turn the power OFF. Failure to do so might cause electric shock.
	Do not disassemble the DCP302. Doing so might cause electric shock or faulty operation.
	Before connecting the DCP302 to the measurement target or external control circuits, make sure that the FG terminal is properly grounded (100Ω max.). Failure to do so might cause electric shock or fire.
	Turn the DCP302 OFF before starting wiring. Failure to do so might cause electric shock.
	Do not touch electrically charged parts such as the power terminals. Doing so might cause electric shock.

CAUTION

	Use the DCP302 within the operating ranges recommended in the specifications (temperature, humidity, voltage, vibration, shock, mounting direction, atmosphere, etc.). Failure to do so might cause fire or faulty operation.
	Do not block ventilation holes. Doing so might cause fire or faulty operation.
	Do not allow lead clippings, chips or water to enter the DCP302 case. Doing so might cause fire or faulty operation.
	Wire the DCP302 properly according to predetermined standards. Also wire the DCP302 using designed power leads according to recognized installation methods. Failure to do so might cause electric shock, fire or faulty operation.
	Inputs to the current input terminals ③① and ③③ on the DCP302 should be within the current and voltage ranges listed in the specifications. Failure to do so might cause fire or faulty operation.
	Firmly tighten the terminal screws at the torque listed in the specifications. Insufficient tightening of terminal screws might cause electric shock or fire.
	Do not use unused terminals on the DCP302 as relay terminals. Doing so might cause electric shock, fire or faulty operation.
	We recommend attaching the terminal cover (sold separately) after wiring the DCP302. Failure to do so might cause electric shock.

CAUTION

	Use induced lighting surge preventive device if there is the risk of power surges caused by lightning. Failure to do might cause fire or faulty operation.
	Before replacing the battery, be sure to turn the power OFF. Failure to do so might cause electric shock.
	Do not touch internal components immediately after turning the power OFF to replace the battery. Doing so might cause burns.
	<ul style="list-style-type: none">· Do not insert the battery with the polarities (+, -) reversed.· Do not use damaged (broken battery skin, leaking battery fluid) batteries.· Do not throw batteries into fires, or charge, short-circuit, disassemble or heat batteries.· Store batteries in low-temperature, dry locations. Failure to observe the above cautions may cause batteries to emit heat or split, or battery fluid to leak.
	Store batteries out of the reach of small children. Batteries are small and are easy to swallow. If a child swallows a battery, consult a physician immediately.
	Do not throw used batteries into fires or dispose at the user site. Return used batteries to Honeywell sales/service office or your dealer.
	If you touch components inside the DCP302, touch a grounded metal object to discharge any static electricity from your body. Otherwise, static electricity might damage the components.

Handling Precautions

After turning the power ON, do not operate the DCP302 for at least 15s to allow the DCP302 to stabilize.



Unpacking

Check the following when removing the DCP302 from its package.

1. Check the model No. to make sure that you have received the product that you ordered.
2. Check the DCP302 for any apparent physical damage.
3. Check the contents of the package against the Package List to make sure that all accessories are included in the package.

After unpacking, handle the DCP302 and its accessories taking care to prevent damage or loss of parts.

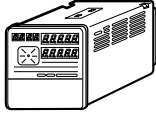
If an inconsistency is found or the package contents are not in order, immediately contact your dealer.

Name	Model No.	Q'ty	Remarks
Body 		1	See 1-5 Model Number Configuration, page 1-5
Mounting bracket 	81405411-001	1pair (2)	
User's Manual 	EN11-6215 (CP-UM-5105E)	1	This manual
Unit indicator seal	N-3132	1	

Request

The filter on the front of the DCP302 is covered with a protective film to protect the surface of the DCP302.

When you have finished mounting and wiring the DCP302, fix cellophane adhesive tape on the corners of the filter, and pull in the direction of the arrow to peel off the protective film.



! Handling Precautions

Peeling off the protective film with your fingernail might scratch the surface of the DCP302.

Organization of This User's Manual

This manual is organized as follows.

Chapter 1. GENERAL

This chapter describes DCP302 applications, features and basic function blocks. It also gives a list of model numbers.

Chapter 2. NAMES & FUNCTIONS OF PARTS

This chapter describes the names and functions of DCP302 parts, input types and range Nos.

Chapter 3. INSTALLATION & MOUNTING

This chapter describes how to mount the DCP302 on control panels. This chapter is required reading for designers of control systems using the DCP302.

Chapter 4. WIRING

This chapter describes the precautions when wiring the DCP302 to a control system and how to wire the DCP302. This chapter is required reading for designers of control systems and supervisors of wiring work.

Chapter 5. FUNCTIONS

This chapter describes the functions of the DCP302. This chapter is required reading for designers of control systems using the DCP302.

Chapter 6. OPERATION

This chapter describes how to switch the basic display states of the DCP302, and select and run programs. This chapter is required reading for designers of control systems using the DCP302 and users of control systems.

Chapter 7. PARAMETER SETUP

This chapter describes how to set up parameters on the DCP302 and the meaning of settings.

Chapter 8. PROGRAM SETUP

This chapter describes how to set up programs on the DCP302 and the meanings of settings.

Chapter 9. MAINTENANCE & TROUBLESHOOTING

This chapter describes points to check when the DCP302 is not working properly or how to remedy trouble that might occur.

Chapter 10. SPECIFICATIONS

This chapter describes the general specifications, performance specifications and external dimensions of the DCP302.

Chapter 11. CALIBRATION

This chapter describes calibration procedures for the functions of the DCP302.

Contents

SAFETY PRECAUTIONS

Unpacking

Request

Organization of This User's Manual

Contents

Conventions Used in This Manual

Chapter 1. GENERAL

1-1	Features	1-1
1-2	Basic Function Blocks	1-2
1-3	Data Structure	1-3
1-4	System Configuration	1-4
	■ System configuration by CPL communications	1-4
1-5	Model Numbers	1-5

Chapter 2. NAMES & FUNCTIONS OF PARTS

2-1	Structure	2-1
2-2	Console	2-2
	■ Basic display state	2-2
	■ Displays	2-2
	■ Keys	2-5
	■ Combined key operations	2-7
	■ Loader jack	2-8
2-3	Input Type and Range No.	2-9
	■ Inputs 1	2-9
	■ Inputs 2	2-10

Chapter 3. INSTALLATION & MOUNTING

3-1	Installation	3-1
	■ Mounting locations	3-1
	■ Noise generating sources and countermeasures	3-2
	■ Dust-proof cover	3-2
3-2	Mounting	3-3
	■ Panel cutout dimensions	3-3
	■ Mounting method	3-4

Chapter 4. WIRING

4-1	Wiring Precautions	4-1
4-2	Compensating Lead	4-3
4-3	Terminal Connections	4-4

4-4	Layout of Terminals and Recommended Lead Draw-out Direction	4-5
4-5	Connecting the Ground and Power Supply	4-6
	■ Power supply	4-6
	■ Ground	4-6
4-6	Wiring of Standard and Add-on Terminal Base	4-7
	■ Standard terminal layout	4-7
4-7	Connecting Inputs (analog inputs)	4-8
	■ Connecting input 1	4-8
	■ Connecting input 2	4-8
4-8	Connecting Control Outputs (outputs 1, 2, 3)	4-10
	■ Relay output (0D)	4-10
	■ Current output (5G)	4-10
	■ Position-proportional output (2G)	4-11
	■ Heat/cool output (3D)	4-12
	■ Heat/cool output (5K)	4-13
4-9	Connecting Auxiliary Outputs (output 3)	4-14
	■ 0D, 5G auxiliary outputs	4-14
4-10	Connecting Event Output (relay output)	4-15
4-11	Connecting Time Event Output (open-collector)	4-16
4-12	Connecting External Switch (RSW) Input	4-17
4-13	Connecting for Communications	4-19
	■ RS-485 interface	4-19
4-14	Isolating Inputs and Outputs	4-22
	■ Control outputs 0D, 5G, 3D, 5K	4-22
	■ Control output 2G	4-22

Chapter 5. FUNCTIONS

5-1	Data	5-1
	■ Data types	5-1
5-2	Program Patterns	5-2
	■ Patterns	5-2
	■ Events 1 to 3	5-3
	■ Time events 1 to 5	5-6
	■ PID set selection	5-8
	■ G.Soak (guarantee soak)	5-9
	■ PV start	5-10
	■ Cycle	5-10
	■ Pattern link	5-11
	■ Tag	5-11
5-3	Modes	5-12
	■ Mode type	5-12
	■ Mode transition	5-14
	■ Mode transition operations	5-15
	■ Mode transition limitations	5-16

5-4	Controller and Programmer	5-17
5-5	Input Processing Functions	5-18
5-6	Output Processing Functions	5-20
■	Exchanging MV1/MV2	5-20
■	Control output CH1	5-21
■	SP output	5-29
■	Auxiliary output	5-30

Chapter 6. OPERATION

6-1	Turning the Power ON	6-1
6-2	Switching the Basic Display	6-2
■	Display in program operation mode	6-3
■	Display in constant-value operation mode	6-7
6-3	Program Selection	6-10
■	How to select the program No.	6-10
6-4	External Switch (RSW) Operations	6-11
■	External switch (RSW) input	6-11
■	Program selection	6-12
■	Read timing	6-13
6-5	Manual Operation and Auto-tuning	6-14
■	Manual operation	6-14
■	Auto-tuning (AT)	6-14

Chapter 7. PARAMETER SETUP

7-1	Parameter Setup	7-1
■	Selecting the setting group in the parameter setup	7-1
■	Moving individual items in the parameter setup	7-2
■	Changing individual items and how to return from the setup state	7-2
7-2	How to Use PARA Keys	7-4
■	How to register functions to PARA keys	7-4
7-3	Parameter Setup List	7-6
■	Variable parameter settings	7-7
■	Description of variable parameter settings	7-9
■	Variable parameter 2 settings	7-16
■	Description of variable parameter 2 settings	7-17
■	Event configuration data settings	7-18
■	Description of event configuration data	7-24
■	PID parameter 1 settings	7-25
■	PID parameter 2 settings	7-28
■	Setup data settings	7-31
■	Description of setup data settings	7-38
■	Table data settings	7-45
■	Description of table data settings	7-46
■	Constant-value operation data settings	7-47

Chapter 8. PROGRAM SETUP

8-1	Program Setup	8-1
■	How to enter program setup	8-1
■	Selecting the program No. to set up	8-1
■	Mode transition	8-2
■	Programming map	8-4
■	Display details	8-5
■	Setting up pattern items	8-5
■	Setting up SP 2 items	8-6
■	Setting up events 1 to 3 items	8-6
■	Setting up time events 1 to 5	8-8
■	Setting up PID set No. items (CH1)	8-9
■	Setting up PID set No. items (CH2)	8-10
■	Setting up G.Soak (guarantee soak) items (CH1)	8-11
■	Setting up G.Soak (guarantee soak) items (CH2)	8-12
■	Setting up PV start items	8-13
■	Setting up cycle items	8-14
■	Setting up pattern link items	8-15
■	Deleting programs	8-16
■	Inserting and deleting segments	8-17
8-2	Copying Programs	8-19
■	Operation	8-19
8-3	General Reset	8-20
■	Operation	8-20

Chapter 9. MAINTENANCE & TROUBLESHOOTING

9-1	Maintenance	9-1
9-2	Self-diagnostics and Alarm Code Display	9-2
■	Self-diagnostics at power ON	9-2
■	Self-diagnostics at each sampling cycle	9-2
■	Intermittent self-diagnostics during operation	9-3
■	Self-diagnostics only when certain functions are operating	9-3
■	Alarm code display	9-3
■	Alarm categories	9-4
9-3	Trouble during Key Entry	9-5
■	Trouble in the basic display state	9-5
■	Trouble in the parameter setup state	9-8
■	Trouble in the program setup state	9-8
9-4	Motor Adjustment is Impossible	9-11
■	Normal wiring for direct motor rotation	9-12
■	Normal wiring for reverse motor rotation	9-12
■	Alarm display caused by wrong wiring and causes	9-12
9-5	When BAT LED Blinks	9-13
■	BAT LED blinking	9-13
■	Replacing the battery	9-13
■	Items to prepare	9-13

Chapter 10. SPECIFICATIONS

10-1 Specifications	10-1
■ Accessories/option list	10-8
10-2 External Dimensions	10-9
■ DCP302	10-9
■ Soft dust-proof cover (sold separately)	10-10
■ Hard dust-proof cover (sold separately)	10-10
■ Terminal cover set (sold separately)	10-10

Chapter 11. CALIBRATION

■ Precautions before calibration	11-1
■ Equipment needed	11-1
11-1 Quick Reference Table for Calibration Items	11-2
11-2 Calibration Procedures	11-6
■ Enter calibration mode	11-6
■ Function test	11-7
■ PV calibration	11-10
■ Cold junction sensor calibration	11-12
■ Current output calibration	11-12

Index

Conventions Used in This Manual

The following conventions are used in this manual.

Handling Precautions

: Handling Precautions indicate items that the user should pay attention to when handling the DCP302.

Note

: Notes indicate useful information that the user might benefit by knowing.

①②③

: Circled numbers indicate steps in a sequence or indicate corresponding parts in an explanation.

»

: Indicates the DCP302 state after an operation.

DISP + ↑ keys

: These icons represent keys on the DCP302's console.

FUNC + PROG keys

: Key combinations like these indicate keys that must be pressed while being held down together.

PA01, C21

: These represent indications on the upper and lower 7-segment displays.

Chapter 1. GENERAL

1 - 1 Features

TheDCP302 is:

- a general-purpose double-loop program controller for controlling temperature, pressure, flow rate and other inputs
- a 2-loop program controller for controlling temperature and relative humidity.

On theDCP302, you can set up to 19 program patterns, and set up to 30 segments to each program pattern.

● High accuracy achieved by multi-range input

Multi-range input allows you to choose between the following input types: thermocouple, resistance temperature detector (RTD), DC voltage and DC current. Accuracy of $\pm 0.1\%FS \pm 1$ digit ($\pm 0.2\%FS \pm 1$ digit for Input 2 only) and a sampling cycle of 0.1 seconds ensures consistently high-precision control.

● Wide range of control output types

A wide range of models supporting various control output types are available: relay time-proportional output, position-proportional output, current output, voltage time-proportional output, and heat/cool output.

On models other than heat-cool control output, you can also choose neural net-based auto-tuning and smart-tuning for inhibiting overshoot, in addition to 2 degrees of freedom PID.

● Enhanced compatibility with PLCs

12 external switch inputs (eight optional), three event outputs and five time event outputs (optional) ensure compatibility with automating systems designed around a PLC core.

● Easy operation

Up to eight frequently changed parameter setups can be registered to the PARA key, facilitating recall of item setups.

1 - 2 Basic Function Blocks

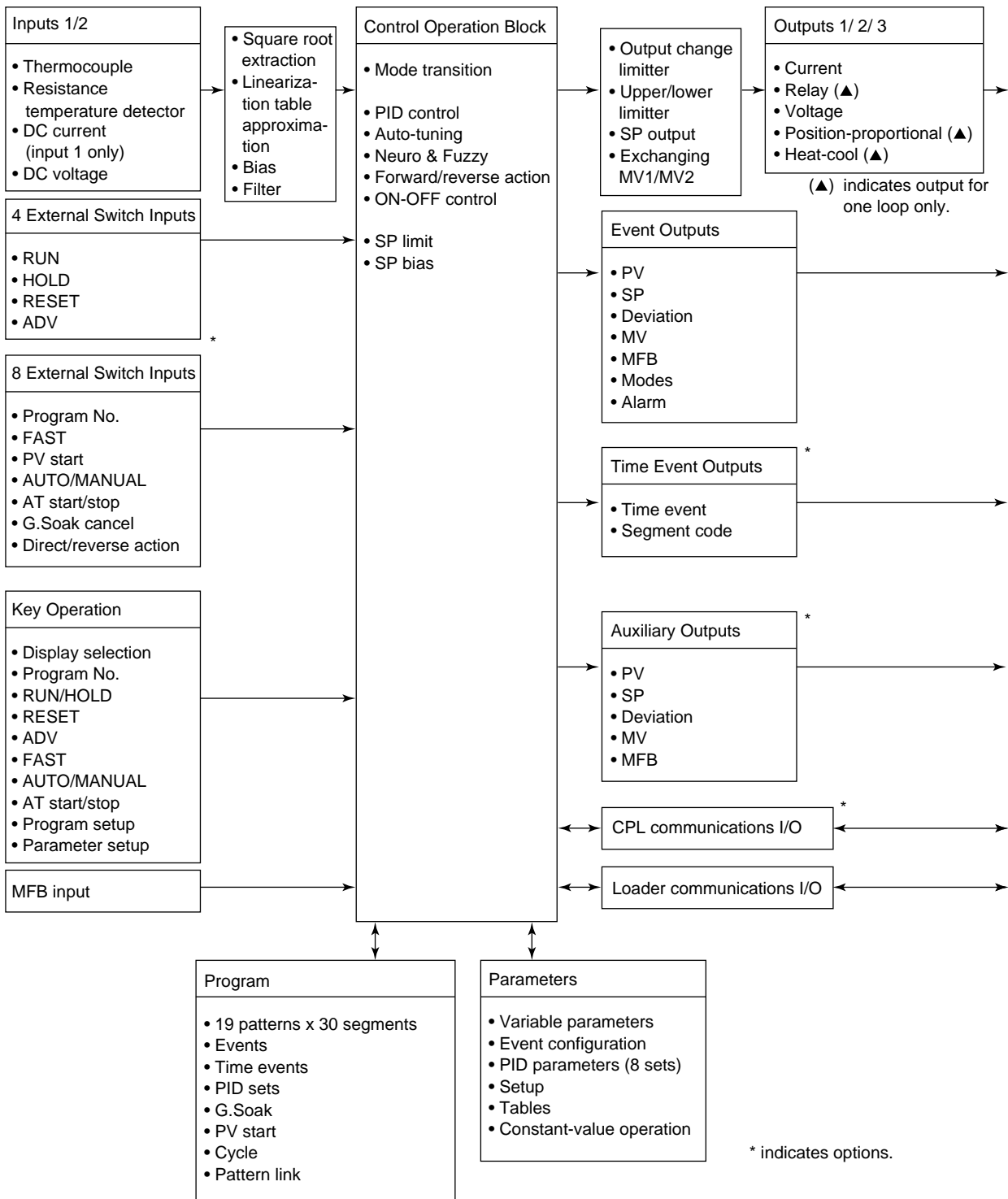

1 - 3 Data Structure

Data is made up of “parameters” that are used mainly for setting controller functions and “programs” that are used for setting operation during program operation of theDCP302.

● **Total of 19 program patterns**

Up to 19 program patterns can be set.

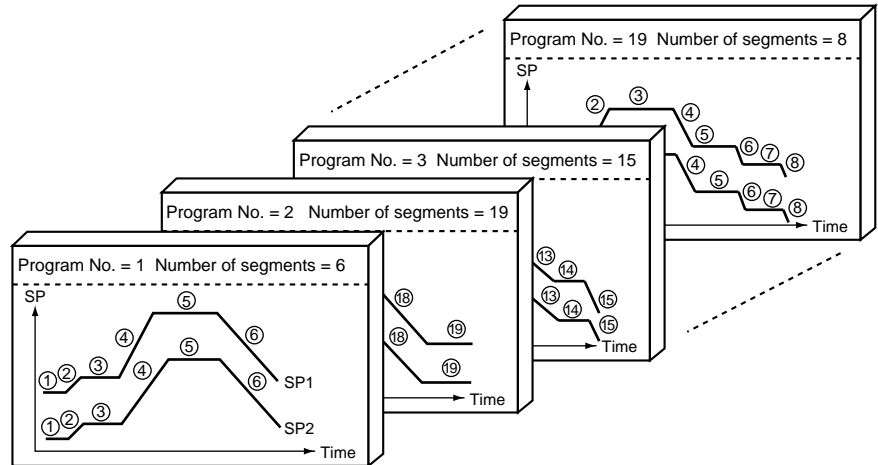

● **Parameters**

Parameters are provided for six types of data: variable parameters, event configuration data, PID parameters, setup data, table data and constant-value operation data.

Variable parameters
Variable parameters 2
Event configuration data
PID parameter 1
PID parameter 2
Setup data
Table data
Constant-value operation data

 **Note**

Variable parameters contain common parameters regardless of channels CH1 and CH2.

1 - 4 System Configuration

■ System configuration by CPL communications

On DCP302 models supporting RS-485 communications (optional), controllers can be connected as slave stations on a communications network.

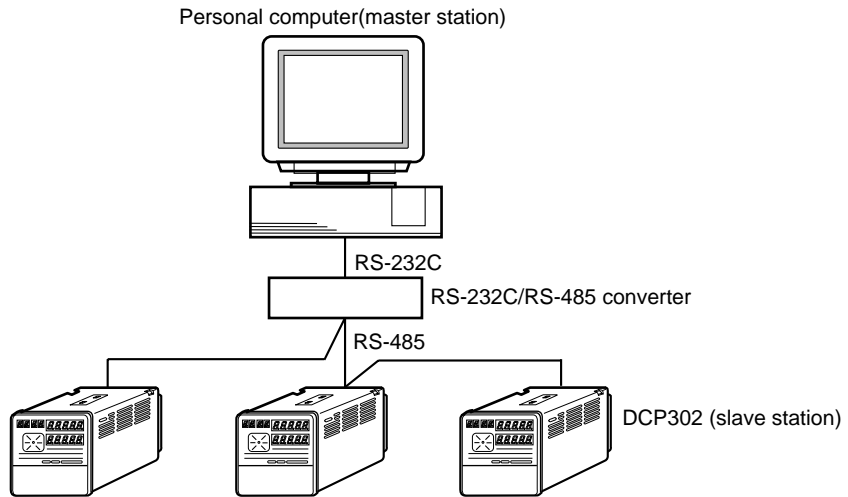

1 - 5 Model Numbers

Basic Model No. : P 3 0 2 E S

Basic Model No.	Output	Function	Power	Option 1	Option 2	Additions	Description
P302							Digital Program Controller (2-loop model)
	0D						Relay outputs + current output
	2G						Position-proportional output + current output
	5G						Current output + current output
	3D						Heat-cool output (relay output + relay output) + current output
	5K						Heat-cool output (current output + current output) + current output
		1					Input 2 channel
		2					Temperature/humidity calculation
			ES				Free power supply (90 to 264 Vac)
				00			No auxiliary output
				01			1 auxiliary output
					0		External switch inputs (4), time events not supported, communications not supported
					1		External switch inputs (12), 5 time events supported, communications not supported
					2		External switch inputs (12), 5 time events supported, RS-485 communications supported
						00	Additional treatment not supported
						T0	Tropical treatment
						K0	Antisulfide treatment
						D0	Inspection Certificate provided
						B0	Tropical treatment + Inspection Certificate provided
						L0	Antisulfide treatment + Inspection Certificate provided
						Y0	Traceability Certificate

Handling Precautions

- On 2G, 3D and 5K output models, only 00 (auxiliary output OFF) can be designated for option 1.
- On current output models other than heat/cool output, you can choose between use of the DCP302 as a controller or a programmer.
- Current output can be changed to voltage output (with current value adjustment function).
- Relay output on 0D output models is time-proportional output.
- Relay output on 3D output models is either time-proportional output or 3-position control output.
- Voltage output is time-proportional output.

Chapter 2. NAMES & FUNCTIONS OF PARTS

2 - 1 Structure

The DCP302 comprises a body, console, case, standard terminal base and add-on terminal base.

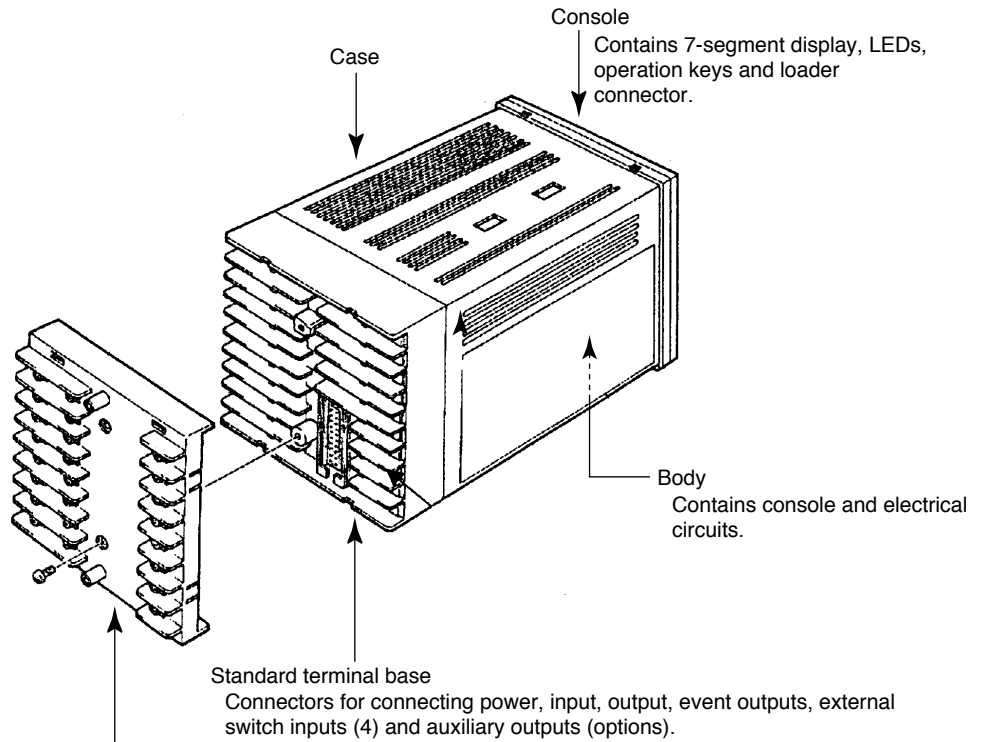

Add-on terminal base

Terminal for connecting external switch inputs (8 options), time event outputs (options) and CPL communications (options).
This base is not provided on models not supporting external switch inputs (8) and time event outputs.

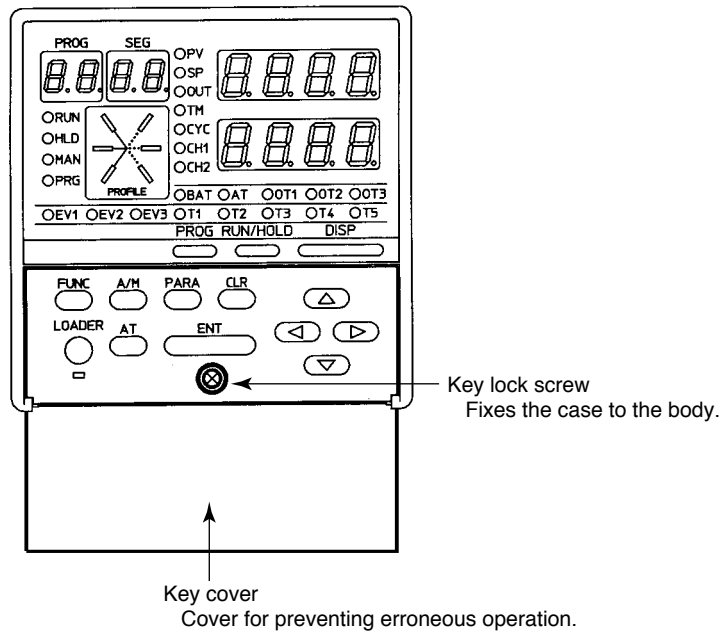

2 - 2 Console

The console comprises keys for operating the DCP302, and displays and LEDs.

■ Basic display state

The “basic display state” is the state in which the DCP302 operating state is displayed on the console.

When the power is turned ON, the DCP302 is in this state.

Key operation changes the DCP302 from the basic display state to one of the parameter setup, program setup, program copy or general reset states. Key operation also returns the DCP302 to the basic display state.

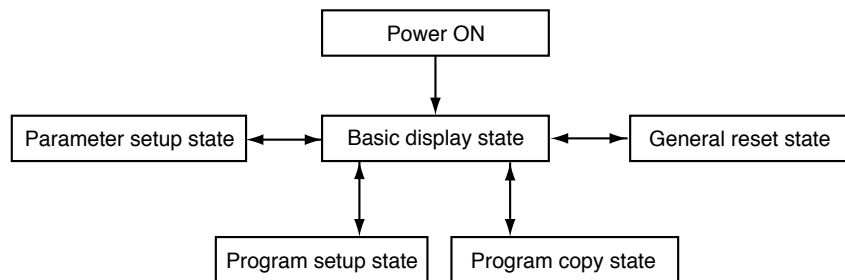

■ Display

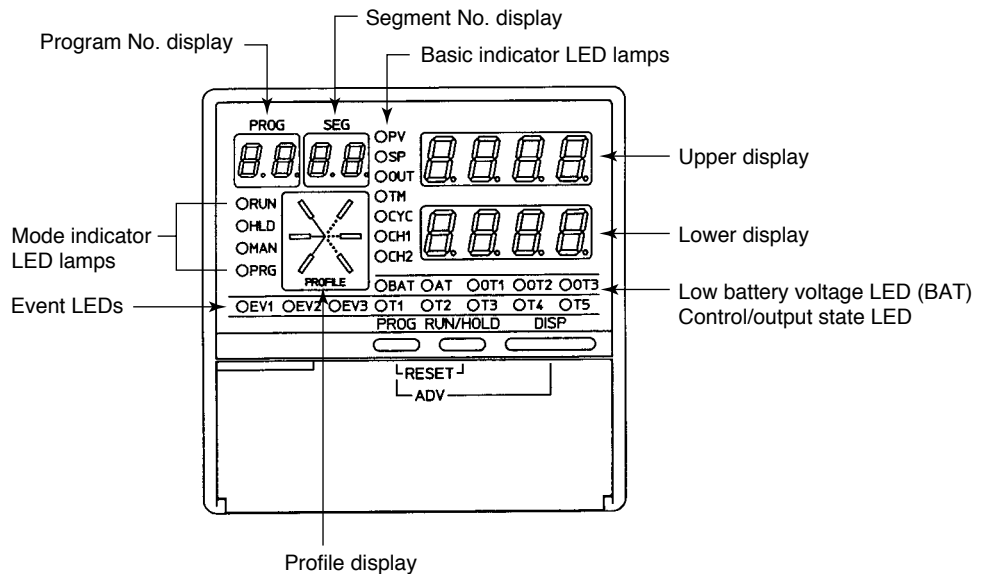

● Program No. display

In the basic display state, this display indicates the currently selected program No.

In the program setup state, this display indicates the program No. currently being set up.

During constant-value operation, this display goes out in the basic display state.

When an alarm occurs in the basic display state, alarm code “AL” is displayed.

● Segment No. display

In the basic display state, this display indicates the currently selected segment No.

In the program setup state, this display indicates the segment No. currently being set up.

During constant-value operation, this display goes out in the basic display state.

In the parameter setup state, this display indicates the item No.

When an alarm occurs in the basic display state, the alarm code No. is displayed.

● **Mode indicator LEDs**

RUN, HLD : Display the READY, RUN, HOLD, FAST and END modes. (See following table.)

Mode LED	READY	RUN	HOLD	FAST	END
RUN	Out	Lit	Out	Blinking	Out
HLD	Out	Out	Lit	Out	Blinking

MAN : Lights when the displayed channel (CH1 or CH2 whose LED is lit) is in the MANUAL mode, blinks when the displayed channel is in the AUTO mode or the undisplayed channel is in the MANUAL mode, and goes out when both channels are in the AUTO mode.

PRG : Lights in the program setup state. Otherwise, this LED is out.

● **Upper display**

In the basic display state, displays PV and other values.

In the parameter setup state, displays the item code.

● **Lower display**

In the basic display state, displays SP, time, output and other values.

In the parameter setup state, displays the item setting value.

● **Low battery voltage LED**

BAT : Blinks when the battery voltage is low. Otherwise, this LED is out.

● **Control/output state LED**

AT : The channel currently displayed in the upper or lower displays (CH1 or CH2 whose LED is lit) blinks during auto-tuning, and lights during smart-tuning. Otherwise, this LED is out.

OT1 : When relay or voltage are assigned to output 1, lights when output is ON and goes out when output is OFF. In the case of 2G output models, lights when the open-side relay is ON and goes out when the relay is OFF.

Lights when current output is assigned to output 1.

OT2 : When relay or voltage are assigned to output 2, lights when output is ON and goes out when output is OFF. In the case of 2G output models, lights when the closed-side relay is ON and goes out when the relay is OFF. Lights when current output is assigned to output 2.

OT3 : Lights when voltage output assigned to output 3 is ON, and goes out when voltage output is OFF. Lights when current output is assigned to output 3, and goes out when output 3 is auxiliary output.

● **Basic indicator LEDs**

PV : Lights during PV display. Otherwise, this LED is out.

SP : Lights during SP display. Otherwise, this LED is out.

OUT : Lights during output display. Otherwise, this LED is out.

TM : Lights during time display. Otherwise, this LED is out.

CYC : Lights during cycle display. Otherwise, this LED is out.

CH1 : Lights when CH1 data is displayed, blinks when CH1 data is displayed with CH2 data. Otherwise, this LED is out.

CH2 : Lights when CH2 data is displayed, blinks when CH2 data is displayed with CH1 data. Otherwise, this LED is out.

● **Event LEDs**

EV1, EV2, EV3 : · In the basic display state or parameter setup state, these LEDs light when each of EV3 events 1 to 3 are ON, and go out when OFF.

- In the program setup (programming) state, these LEDs light when each of the items for events 1 to 3 are displayed. Otherwise, these LEDs are out.

T1, T2, T3, T4, T5 : · These LEDs light when each of time events 1 to 5 are ON, and go out when OFF.

- In the program setup (programming) state, these LEDs light when each of the items for time events 1 to 5 are displayed. Otherwise, these LEDs are out.

● **Profile display**

Displays the tendencies (rise, soak, fall) of the program pattern of the displayed channel (CH1 or CH2 whose LED is lit) in the upper/lower display. Blinks during G.Soak standby, and light successively after the power is turned ON.

■ Keys

! Handling Precautions

Do not operate the console keys using a sharp-pointed object such as a propelling pencil or needle. Doing so might damage the console.

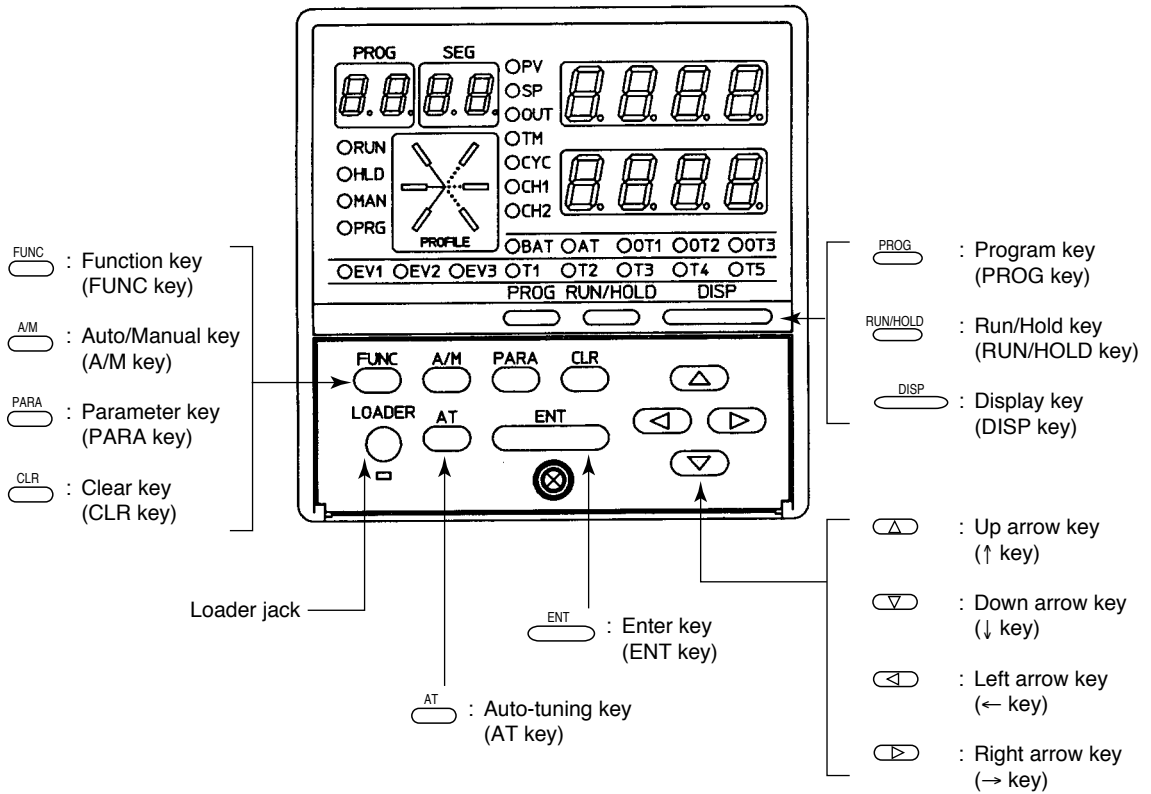

Category	Function	Key operation
Basic display state	To change the display	DISP
	To switch the display channel	FUNC + DISP
	To change the program No. in ascending order (in READY mode)	PROG
	To change the program No. in descending order (in READY mode)	↓
	To run the program (in READY, HOLD, FAST modes)	RUN/HOLD
	To hold the program (in RUN mode)	
	To reset the program (in READY, HOLD, FAST, END modes)	PROG + RUN/HOLD
	To advance the program (in RUN, HOLD, FAST modes)	PROG + DISP
	To run the program fast (in RUN, HOLD modes)	FUNC + →
	To execute manual operation (in AUTO mode)	A/M
	To execute automatic operation (in MANUAL mode)	
	To start auto-tuning (when not executing auto-tuning)	AT
	To cancel auto-tuning (when executing auto-tuning)	
To change values during manual operation (when MV or SP is blinking)	↑ ↓ ← →	
Parameter setup	Starts parameter setup. So, the controller enters selection of setup group (major item). (in basic display state)	FUNC + PARA
	To change the setup group (major item)	PARA ↑ ↓
	To fix the setup group (major item)	ENT
	To move between individual items (minor items)	↑ ↓ ← →
	To start changing of individual item setting values	ENT
	To end changing of individual item setting values (while setting value is blinking)	
	To change individual item setting values (while setting value is blinking)	↑ ↓ ← →
	To cancel changing of individual item setting values (in basic display state)	PARA
	To select setup group	
	To end parameter setup	DISP
PARA key Assignment item setup	To start changing assignment item setting values (in basic display state)	PARA
	To move to next item by assignment item, and start changing setting values	
	To change assignment item setting values (while setting value is blinking)	↑ ↓ ← →
	To end changing of assignment item setting values (while setting value is blinking)	ENT
	To start changing assignment item setting values	
	To end assignment item setup	DISP

Category	Function	Key operation
Program setup	To start program setup (programming) (in basic display state)	FUNC + PROG
	To move between program items and segment Nos.	↑ ↓ ← →
	To start changing of item setting values (while setting value is blinking)	ENT
	To end changing of item setting values (while setting value is blinking)	
	To change item setting values (while setting value is blinking)	↑ ↓ ← →
	To clear item setting (while setting value is blinking)	FUNC + CLR
	To cancel changing item setting values (while setting value is blinking)	DISP
	To insert/delete segments	FUNC + ENT
	To change the program No. in ascending order	FUNC + PROG
	To change the program No. in descending order	FUNC + ↓
	To end program setup (programming)	DISP
	Program copy	To start program copy (in basic display state)
To change the copy destination program No.		↑ ↓
To execute program copy (while setting value is blinking)		ENT
To end program copy		DISP
General reset	To check general reset (in basic display state)	FUNC + CLR + DISP
	To execute general reset	ENT
	To cancel general reset	DISP

■ Combined key operations

- FUNC + DISP** : Displayed channel switching keys
Press the DISP key with the FUNC key held down in the basic display state to switch the displayed channel.
- PROG + RUN/HOLD** : Reset keys
Press the RUN/HOLD key with the PROG key held down in the basic display state to reset the DCP302.
The DCP302 enters the READY mode from the RUN, HOLD, FAST or END modes.
The DCP302 cannot be reset in the READY mode by key operation.
- PROG + DISP** : Advance keys
Press the DISP key with the PROG key held down in the program operation mode in the basic display state to advance the program.
In the RUN, HOLD or FAST modes, the program advances to the next segment.
The DCP302 cannot advance in the READY mode by key operation.
- FUNC + →** : Fast keys
Press → with the FUNC key held down in the program operation mode in the basic display state to fast-operate the program.

	The DCP302 enters the FAST mode from the RUN or HOLD modes.
FUNC + PARA	: Parameter setup keys Press the PARA key with the FUNC key held down in the basic display state to move to selection of the setting group (major items) in the parameter setup state.
FUNC + PROG	: Program setup (programming) keys Press the PROG key with the FUNC key held down in the program operation mode in the basic display state to move to the program setup (programming) state. Press the PROG key with the FUNC key held down in the program setup state to change the No. of the program to be set up in ascending order.
FUNC + ↓	: Program No. change keys Press ↓ with the FUNC key held down in the program setup state to change the No. of the program to be set up in descending order.
FUNC + CLR	: Program item delete keys Press the CLR key with the FUNC key held down during entry of settings in the program setup state to clear the setting.
FUNC + ENT	: Segment insert/delete keys Press the ENT key with the FUNC key held down at the SP or time items in the program setup state to move to the segment insert/delete screen.
↑ + PROG	: Program copy keys Press the PROG key with ↑ held down in the program operation READY mode in the basic display state to move to the program copy screen.
FUNC + CLR + DISP	: General reset keys Press the CLR key and the DISP key with the FUNC key held down in the READY AUTO mode in the basic display state to move to the general reset confirmation screen.

■ Loader jack

This jack is for connecting the loader.

Objects other than the loader plug should not be inserted into this jack.

The loader jack is not isolated from internal digital circuits. Be sure to cap the loader jack when it is not in use.

2 - 3 Input Type and Range No.

■ Input 1

● Thermocouple

Input Type	Range No.	Code	Temp. Range (°C)	Temp. Range (°F)
K (CA)	0	K09	0 to 1200	0 to 2400
K (CA)	1	K08	0.0 to 800.0	0 to 1600
K (CA)	2	K04	0.0 to 400.0	0 to 750
K (CA)	3	K29	-200 to +1200	-300 to +2400
K (CA)	4	K44	-200.0 to +300.0	-300 to +700
K (CA)	5	K46	-200.0 to +200.0	-300 to +400
E (CRC)	6	E08	0.0 to 800.0	0 to 1800
J (IC)	7	J08	0.0 to 800.0	0 to 1600
T (CC)	8	T44	-200.0 to +300.0	-300 to +700
B (PR30-6)	9	B18	0 to 1800	0 to 3300
R (PR13)	10	R16	0 to 1600	0 to 3100
S (PR10)	11	S16	0 to 1600	0 to 3100
W (WRe5-26)	12	W23	0 to 2300	0 to 4200
W (WRe5-26)	13	W14	0 to 1400	0 to 2552
PR40-20	14	D19	0 to 1900	0 to 3400
Ni-Ni-Mo	15	Z13	0 to 1300	32 to 2372
N	16	U13	0 to 1300	32 to 2372
PL II	17	Y13	0 to 1300	32 to 2372
DIN U	18	Z08	-200.0 to +400.0	-300 to +750
DIN L	19	Z07	-200.0 to +800.0	-300 to +1600
Golden iron chromel	20	Z06	0.0 to +300.0 K	—

● Resistance temperature detector (RTD)

Input Type	Range No.	Code	Temp. Range (°C)	Temp. Range (°F)	
JIS'89 Pt100 (IEC Pt100 Ω)	32	F50	-200.0 to +500.0	-300 to +900	
	33	F46	-200.0 to +200.0	-300 to +400	
	34	F32	-100.0 to +150.0	-150.0 to +300.0	
	35	F36	-50.0 to +200.0	-50.0 to +400.0	
	36	F38	-60.0 to +40.0	-76.0 to +104.0	
	37	F33	-40.0 to +60.0	-40.0 to +140.0	
	38	F05	0.0 to 500.0	0.0 to 900.0	
	39	F03	0.0 to 300.0	0.0 to 500.0	
	40	F01	0.00 to 100.00	0.0 to 200.0	
	JIS'89 JPt100	48	P50	-200.0 to +500.0	-300 to +900
		49	P46	-200.0 to +200.0	-300 to +400
50		P32	-100.0 to +150.0	-150.0 to +300.0	
51		P36	-50.0 to +200.0	-50.0 to +400.0	
52		P38	-60.0 to +40.0	-76.0 to +104.0	
53		P33	-40.0 to +60.0	-40.0 to +140.0	
54		P05	0.0 to 500.0	0.0 to 900.0	
55		P03	0.0 to 300.0	0.0 to 500.0	
56	P01	0.00 to 100.00	0.0 to 200.0		

● DC current, DC voltage

Input Type	Range No.	Code	Range (programmable)
4 to 20 mA	64	C01	-1999 to +9999
0 to 20 mA	65	C08	
0 to 10 mA	66	M01	
-10 to +10 mV	67	L02	
0 to 100 mV	68	L01	
0 to 1 V	69	L04	
-1 to +1 V	70	L08	
1 to 5 V	71	V01	
0 to 5 V	72	L05	
0 to 10 V	73	L07	

■ Input 2

● Thermocouple

Input Type	Range No.	Code	Temp. Range (°C)	Temp. Range (°F)
K (CA)	128	K44	-200.0 to +300.0	-300 to +700
K (CA)	129	K29	-200 to +1200	-300 to +2400

● Resistance temperature detector (RTD)

Input Type	Range No.	Code	Temp. Range (°C)	Temp. Range (°F)
JIS'89Pt100 (IEC Pt100 Ω)	160	F36	-50.0 to +200.0	-50.0 to +400.0
	161	F01	0.00 to 100.00	0.0 to 200.0
JIS'89 JPt100	176	P36	-50.0 to +200.0	-50.0 to +400.0
	177	P01	0.00 to 100.00	0.0 to 200.0

● DC current, DC voltage

Input Type	Range No.	Code	Range (programmable)
0 to 10 V	192	L07	-1999 to +9999
1 to 5 V	193	V01	

! Handling Precautions

- The unit of code Z06 is Kelvin (K)
- The lower limit readout of code B18 is 20°C.
The lower limit readout of codes K44, K46, T44, Z08 and Z07 is -199.9°C.
- The lower limit readout of codes F50, F46, P50 and P46 is -199.9°C.
- The upper limit readout of codes F01 and P01 is 99.99°C.
- The PV lower limit alarm does not occur with code F50.
However, note that the PV lower limit alarm occurs at a line disconnection if input has been downscaled when input is disconnected during setup.
- The number of digits past the decimal point for DC current and DC voltage is programmable within the range 0 to 3.

Chapter 3. INSTALLATION & MOUNTING

3 - 1 Installation

WARNING



Before removing or mounting the DCP302, be sure to turn the power OFF.
Failure to do so might cause electric shock.



Do not disassemble the DCP302.
Doing so might cause electric shock.

CAUTION



Use the DCP302 within the operating ranges recommended in the specifications (temperature, humidity, voltage, vibration, shock, mounting direction, atmosphere, etc.).
Failure to do so might cause fire or faulty operation.



Do not block ventilation holes.
Doing so might cause fire or faulty operation.



Do not allow lead clippings, chips or water to enter the DCP302 case.
Doing so might cause fire or faulty operation.

■ Mounting locations

Avoid installing the DCP302 in the following locations:

- Locations subject to low and high temperature and humidity
- Locations subject to direct sunlight, wind or rain
- Locations subject to splashing by liquids (e.g. water, oil or chemicals).
- Locations subject to corrosive gases or flammable gases
- Locations subject to dust or oil smoke
- Locations subject to vibration or shock
- Locations where magnetic fields are generated
- Locations near sources of electrical noise (such as high-voltage ignition equipment, welders)
- Locations near flammable liquid or steam

■ **Noise generating sources and countermeasures**

- Generally, the following generate electrical noise:
 - ① Relays and contacts
 - ② Solenoid coils, solenoid valves
 - ③ Power lines (in particular, 90 Vac min.)
 - ④ Induction loads
 - ⑤ Inverters
 - ⑥ Motor commutators
 - ⑦ Phase angle control SCR
 - ⑧ Radio communications equipment
 - ⑨ Welding equipment
 - ⑩ High-voltage ignition equipment

- If the influence of electrical noise cannot be eliminated, we recommend taking the following countermeasures:
 - Provision of a CR filter for fast-rising noise
Recommended CR filter: Model No. 81446365-001
 - Provision of a varistor for high wave height noise.
Recommended varistor: Model No. 81446366-001 (100V)
81446367-001 (200V)

 **Handling Precautions**

The varistor may become short-circuited when trouble occurs. Pay attention to this when providing a varistor on the DCP302.

■ **Dust-proof cover**

Use the dust-proof cover when using the DCP302 in a dusty or dirty location, and to prevent inadvertent operation.

Two dust proof-covers are provided, hard or soft, each with the following differing functions.

Type	Confirmation on Display	Operation
Hard	○	X
Soft	○	○

○ indicates that a function can be used.

3 - 2 Mounting

The following describes how to mount the DCP302.

■ Panel Cutout Dimensions

Use a steel panel at least 2 mm thick for mounting the DCP302.

Unit: mm

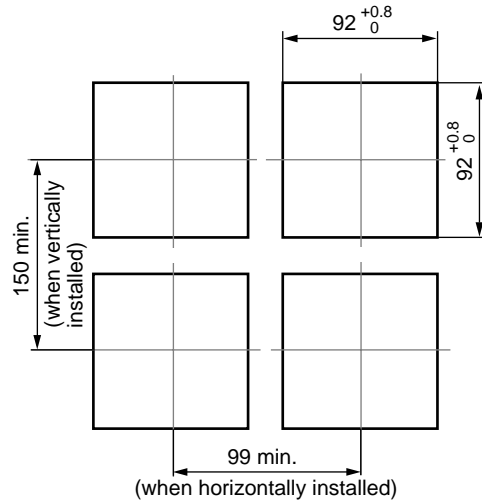

! Handling Precautions

When mounting the DCP302, take care to prevent the temperature at the lower surface of the DCP302's case from exceeding the operating temperature range (0 to 50°C), particularly when mounting vertically or during multiple mounting.

■ Mounting method

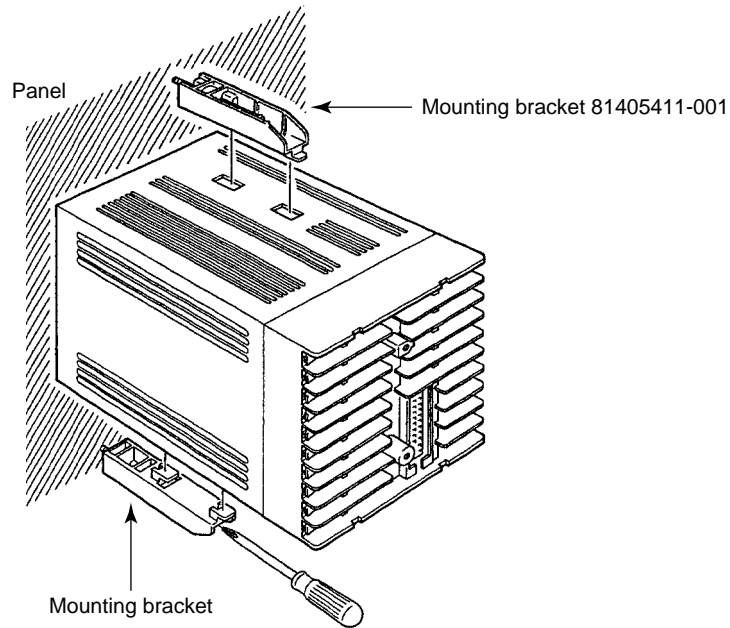

- Firmly secure the top and bottom of the DCP302 by the mounting brackets.
- When mounting the DCP302, secure by lower mounting bracket ① first.

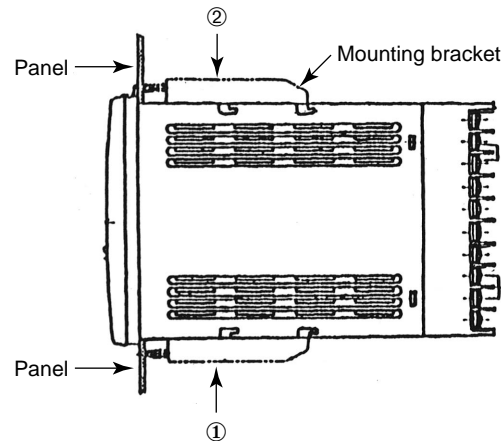

! Handling Precautions

To secure the DCP302, tighten the screw on the mounting bracket (supplied) until there is no more play and then tighten a further full turn. Take care not to overtighten the screw. Doing so might deform or damage the case.

- Keep the mounting angle to within 10° from the horizontal at both the DCP302 rear top and bottom.

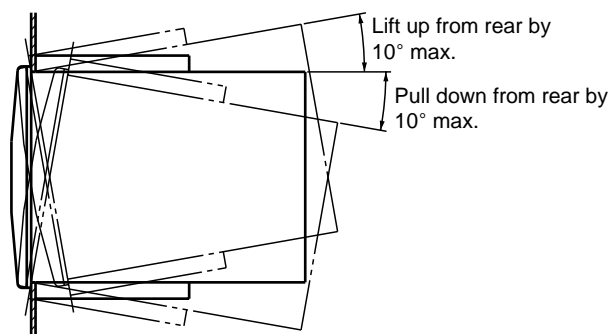

Chapter 4. WIRING

4 - 1 Wiring Precautions

WARNING



Before connecting the DCP302 to the measurement target or external control circuits, make sure that the FG terminal is properly grounded (100 Ω max.). Failure to do so might cause electric shock or fire.



Before wiring, be sure to turn the power OFF.
Failure to do so might cause electric shock.



Do not touch electrically charged parts such as the power terminals.
Doing so might cause electric shock.

CAUTION



Wire the DCP302 properly according to predetermined standards. Also wire the DCP302 using designed power leads according to recognized installation methods.
Failure to do so might cause electric shock, fire or faulty operation.



Do not allow lead clippings, chips or water to enter the DCP302 case.
Doing so might cause fire or faulty operation.



Inputs to the current input terminals ㉑ and ㉒ on the DCP302 should be within the current and voltage ranges listed in the specifications.
Failure to do so might cause fire or faulty operation.



Firmly tighten the terminal screws at the torque listed in the specifications.
Insufficient tightening of terminal screws might cause electric shock or fire.



Do not use unused terminals on the DCP302 as relay terminals.
Doing so might cause electric shock, fire or faulty operation.



We recommend attaching the terminal cover (sold separately) after wiring the DCP302.
Failure to do so might cause electric shock.



Use the relays on the DCP302 within the service life listed in the specifications.
Continued use of the relays after the recommended service life might cause fire or faulty operation.



Use induced lightning surge preventive device if there is the risk of power surges caused by lightning.
Failure to do might cause fire or faulty operation.

Handling Precautions

- Before wiring the DCP302, check the DCP302 model No. and terminal Nos. on the label on the rear of the body.

After wiring the DCP302, be sure to check the wiring for any mistakes before turning the power ON.

- Maintain a distance of at least 50 cm between I/O signal leads or communications leads and the power lead. Also, do not pass these leads through the same piping or wiring duct.
- When wiring with crimped terminals, take care to prevent contact with adjacent terminals.
- When connecting the DCP302's thermocouples in parallel to other controllers, make sure that the total input impedance of the other controllers is at least 1 M Ω .

If the input impedance is less than 1 M Ω , the DCP302 may not be able to detect sensor disconnection.

- Precautions when combining the DCP302 with other data input device
When inputting the DCP302's I/O (parallel connection in case of input) to an A/D converter or analog scanner, read data may fluctuate.

To prevent this, adopt one of the following measures.

- ① Use a low-speed, integrating type A/D converter.
 - ② Insert an isolator without a switching power supply between the DCP302 and A/D converter.
 - ③ Average the data on a personal computer when reading data.
 - ④ If possible, set a filter for the input.
- Provide a switch within the operator's reach on the instrumentation power supply wiring for turning the mains power OFF.
 - Provide a delay-type (T) rated current 1A and rated voltage 250 V fuse on the instrumentation power supply wiring. (IEC 127)

4 - 2 Compensating Lead

When a thermocouple input is input to the DCP302, connect the bare thermocouple lead to the terminal. If the thermocouple is located a long way from the DCP302 or the thermocouple is connected to a terminal, extend the connection using a compensating lead and then connect to the terminal. Use shielded compensating leads only.

Note

- For I/O other than thermocouples, use JCS-364 shielded instrument polyethylene insulated vinyl sheath cable or equivalent product. (This is generally referred to “shielded twisted cable for instruments.”) The following cables are recommended.

Fujikura Cable Co.	2-core	IPEV-S-0.9 mm ² x 1P
	3-core	ITEV-S-0.9 mm ² x 1T
Hitachi Cable Co.	2-core	KPEV-S-0.9 mm ² x 1P
	3-core	KTEV-S-0.9 mm ² x 1T

- Shielded, multi-core microphone cord (MVVS) can be used if there is little electromagnetic induction.

4 - 3 Terminal Connections

Use crimped terminals that fit onto M3.5 screws.

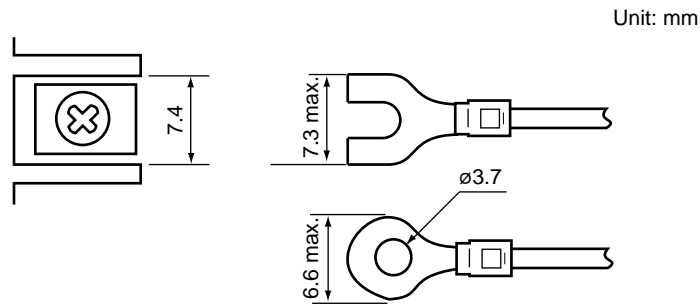

! Handling Precautions

- When installing the DCP302 in locations subject to vibration or impact, be sure to use round crimped terminals to prevent the lead from coming loose from the terminal.
- When wiring with crimped terminals, take care to prevent contact with adjacent terminals.
- The recommended tightening torque for the terminal screws is 0.78 to 0.98 N•m.

4 - 4 Layout of Terminals and Recommended Lead Draw-out Direction

Wiring is carried out on the standard terminal base or add-on terminal base. The following diagram shows the recommended draw-out directions for the leads on the standard terminal base.

The lead draw-out directions are the same when using the add-on terminal base.

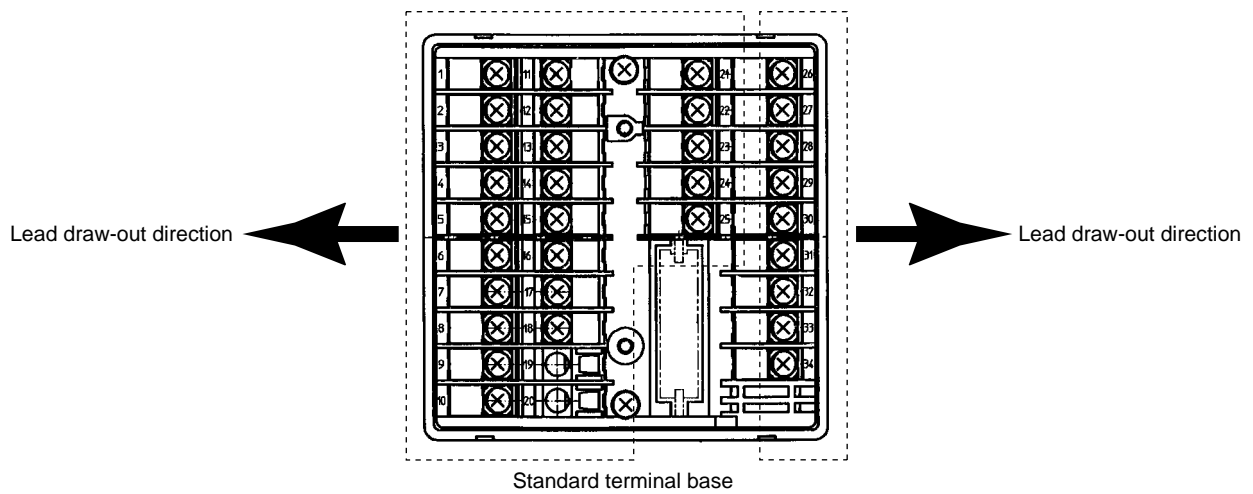
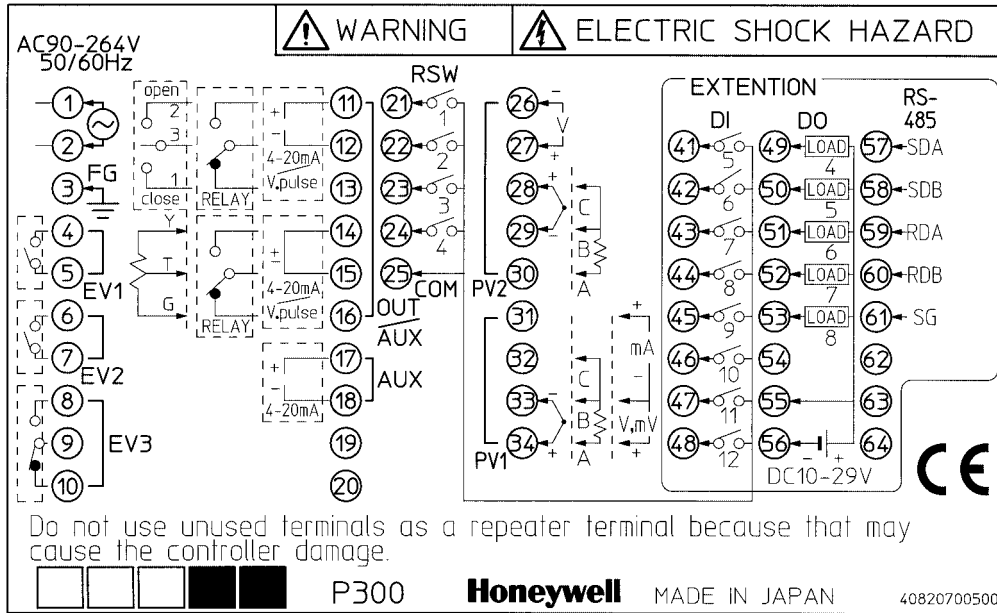

4 - 5 Connecting the Ground and Power Supply

■ Power supply

Connect the DCP302 to a single-phase power supply for instrumentation, and take measures to prevent the influence of electrical noise.

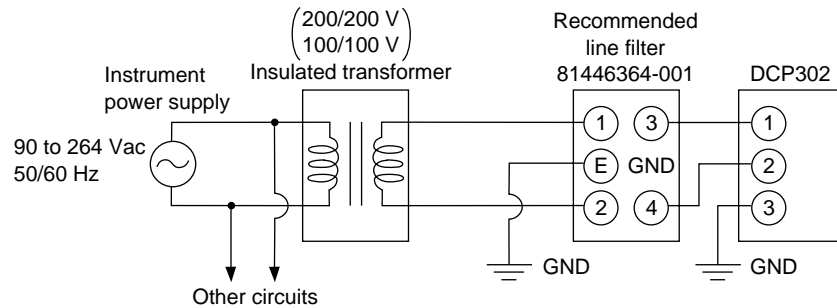

! Handling Precautions

- If the power supply generates a lot of electrical noise, we recommend inserting an insulating transformer in the power circuit and using a line filter.

Recommended line filter:

Model No. 81446364-001

- After providing anti-noise measures, do not bundle primary and secondary power leads together, or pass them through the same piping or wiring duct.

■ Ground

When it is difficult to ground shielded cable, prepare a separate ground terminal (earth bar).

Ground type: 100 Ω max.

Ground cable: 2 mm sq. min. annealed copper wire (AWG14)

Cable length: Max. 20 m

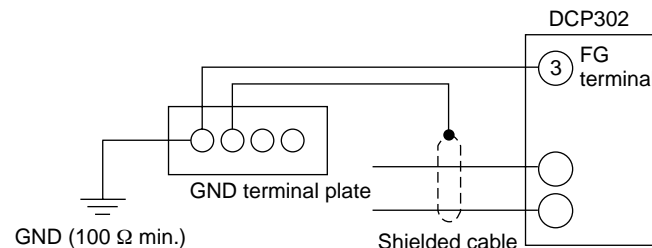

! Handling Precautions

Use only the FG terminal ③ on the DCP302 for grounding. Do not ground across other terminals.

4 - 6 Wiring of Standard and Add-on Terminal Base

Standard terminal layout

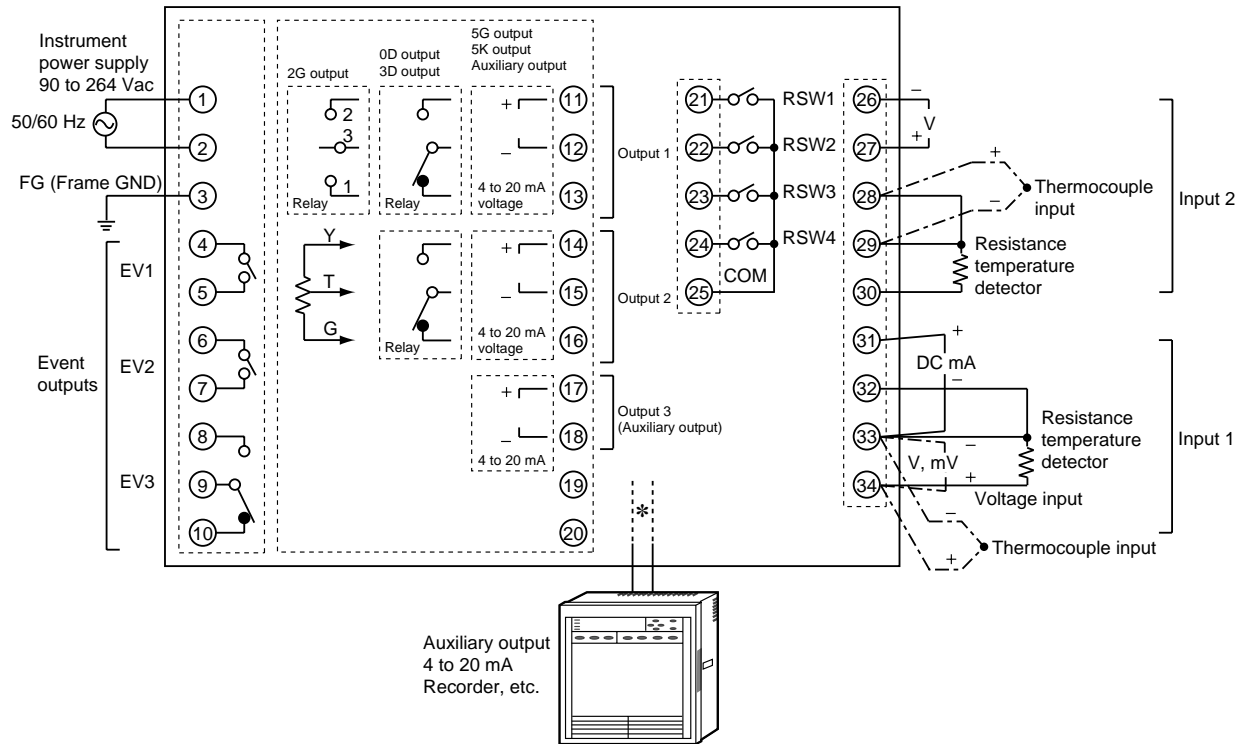

2G, 3D or 5K models do not support auxiliary output.
 On 0D or 5G models, terminal Nos. 17 and 18 are the auxiliary outputs.)

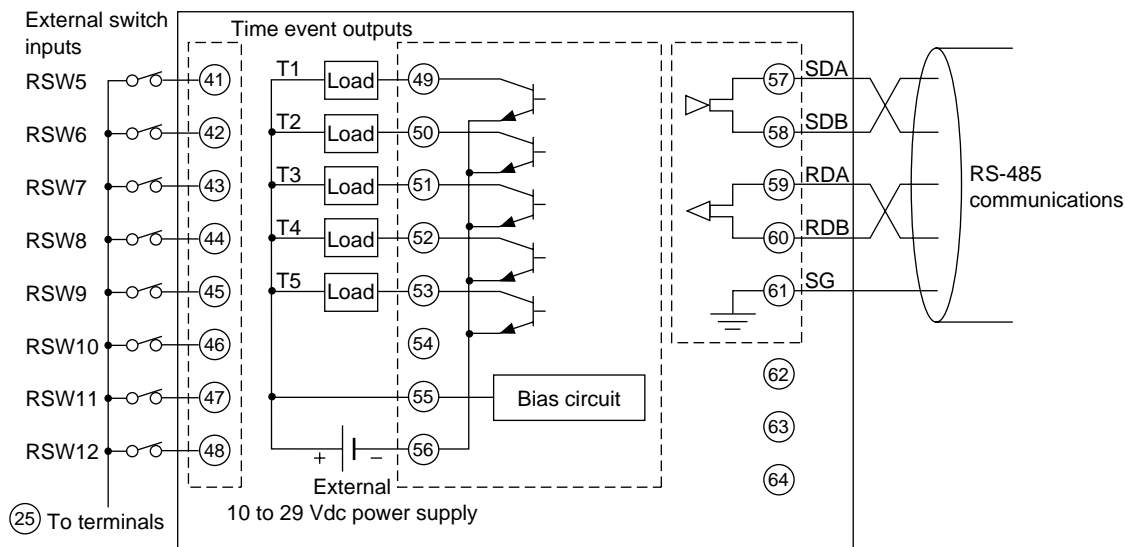

4 - 7 Connecting Inputs (analog inputs)

⚠ CAUTION



Inputs to the current input terminals ③① and ③③ on the DCP302 should be within the current and voltage ranges listed in the specifications. Failure to do so might cause fire or faulty operation.

■ Connecting input 1

Multiple input 1 supports various sensor inputs. Connect as follows according to the sensor being used:

- Thermocouple input

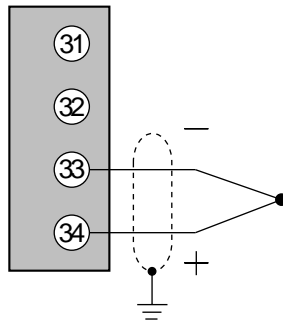

- RTD input

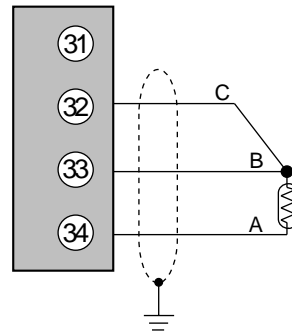

- DC voltage input

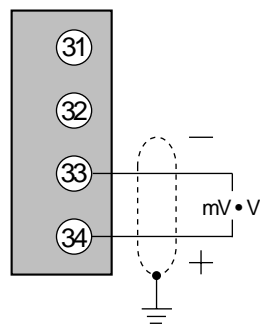

- DC current input

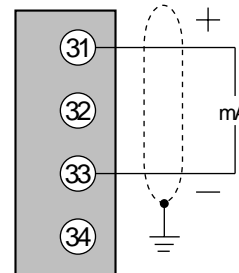

■ Connecting input 2

Multiple input 2 supports various sensor inputs. Connect as follows according to the sensor being used:

- Thermocouple input

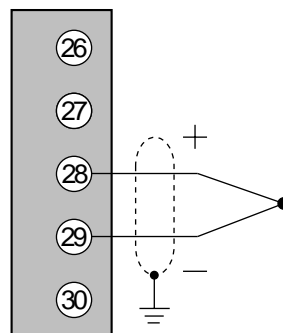

- RTD input

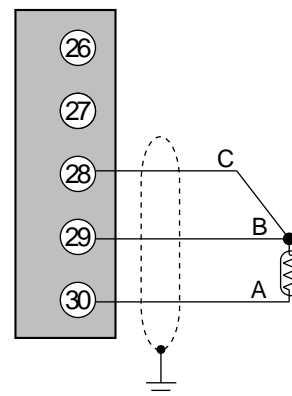

- DC voltage input

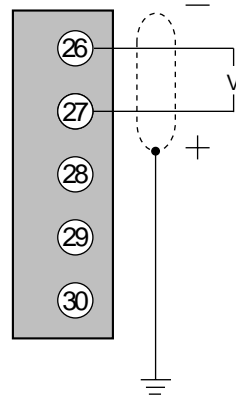

! Handling Precautions

- Applying voltage across DC current input terminals ③① and ③③ may cause faulty operation.
- Pay attention to polarities (+, -) when wiring inputs.
- Use only shielded cable for wiring inputs.
- When a thermocouple is used as the input, prevent wind from blowing against the terminals. This may cause an error in readings.

4 - 8 Connecting Control Outputs (outputs 1, 2, 3)

WARNING



Before wiring, or removing/mounting the DCP302, be sure to turn the power OFF.
Failure to do so might cause electric shock.

■ Relay output (0D)

Connect as follows:

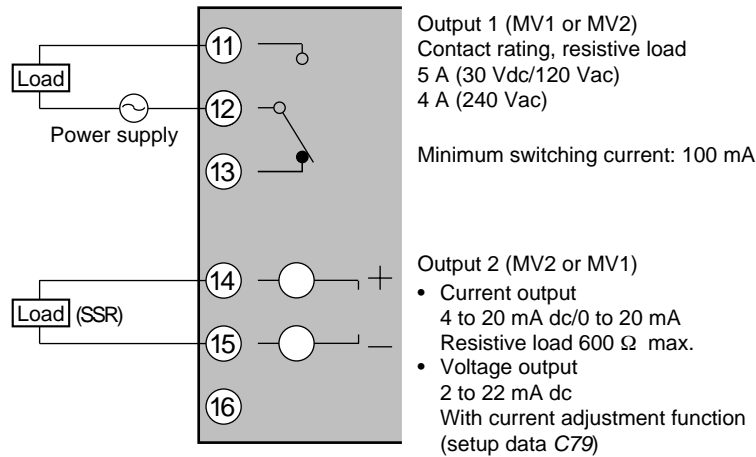

Handling Precautions

- When switching small currents, connect a bleeder resistor to allow current flow of the minimum relay switching input (100 mA min.).
- Current output and voltage output can be selected by setup data C 76. Voltage output is reliant on an internal fixed-current circuit. Set the current value in the setup data so that the optimum voltage is obtained matched to the conditions of the SSR in use and the load. Factory setting: general-purpose SSR voltage value.
- Internal connection of MV1 (CH1 MV) and MV2 (CH2 MV), and output 1 and output 2 can be selected in setup data C44.
- 4 to 20 mA dc and 0 to 20 mA dc can be selected in setup data C90.

■ Current output (5G)

Connect as follows.

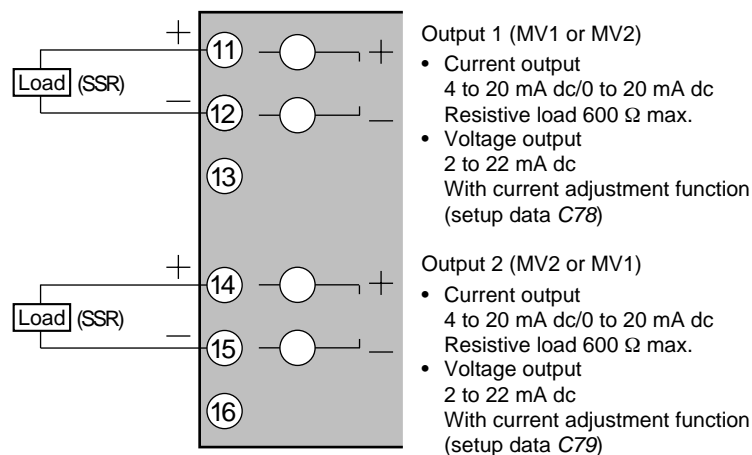

! Handling Precautions

- Current output and voltage output can be selected by setup data C 75 and C 76.
Voltage output is reliant on an internal fixed-current circuit.
Set the current value in the setup data so that the optimum voltage is obtained matched to the conditions of the SSR in use and the load.
Factory setting: general-purpose SSR voltage value.
- Internal connection of MV1 (CH1 MV) and MV2 (CH2 MV), and output 1 and output 2 can be selected in setup data C44.
- 4 to 20 mA dc and 0 to 20 mA dc can be selected in setup data C90.

■ Position-proportional output (2G)

Connect as follows paying attention to the switching direction:

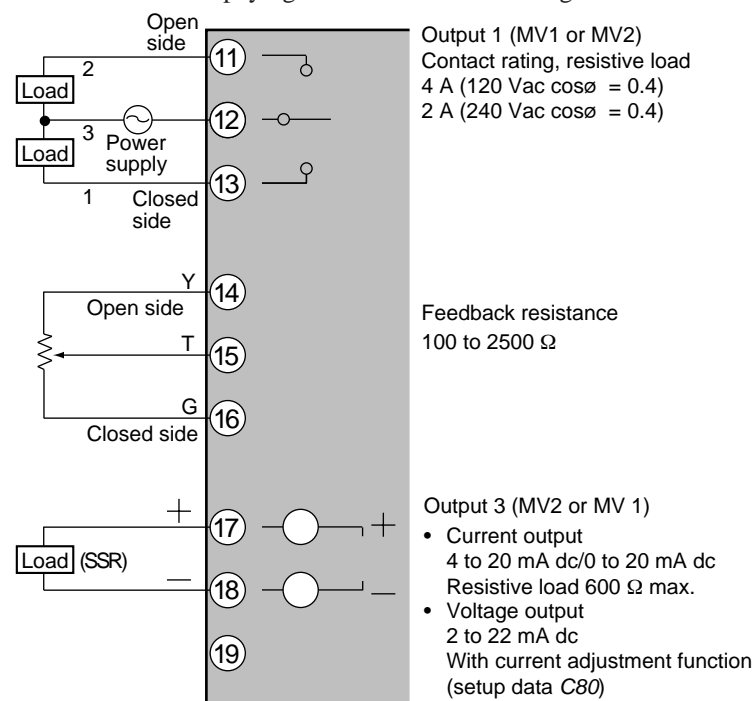

! Handling Precautions

- The life of internal relays is limited.
Avoid setting the PID constant in such a way that results in excessive repeated ON/OFF switching.
- When using a 100/200 Vac motor, pay attention to rush current and the contact rating. If necessary, provide an external auxiliary relay.
- Maintain a distance of at least 30 cm between the wiring for motor terminals ① ② ③ and feedback resistor terminals ④ ⑤ ⑥.
(Do not wire the leads in the same duct or use 6-core cable. Doing so might result in faulty controller operation caused by electrical noise when the motor is started up.)
- When controlling without motor feedback with variable parameter *m-C* set to "2", terminals ④ ⑤ ⑥ need not be connected.
- Current output and voltage output can be selected by setup data C77.
Voltage output is reliant on an internal fixed-current circuit.
Set the current value in the setup data so that the optimum voltage is obtained matched to the conditions of the SSR in use and the load.
Factory setting: general-purpose SSR voltage value.
- Internal connection of MV1 (CH1 MV) and MV2 (CH2 MV), and output 1 and output 2 can be selected in setup data C44.
- 4 to 20 mA dc and 0 to 20 mA dc can be selected in setup data C90.

■ Heat/cool output (3D)

Connect as follows:

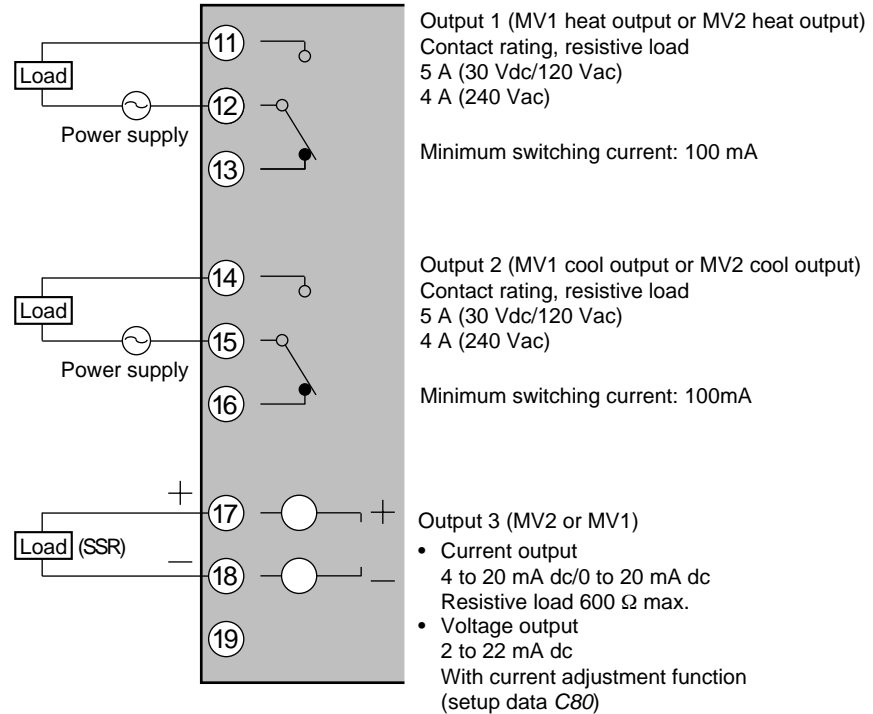

! Handling Precautions

- When switching small currents, connect a bleeder resistor to allow current flow of the minimum relay switching input (100 mA min.).
- Current output and voltage output can be selected by setup data C 77. Voltage output is reliant on an internal fixed-current circuit. Set the current value in the setup data so that the optimum voltage is obtained matched to the conditions of the SSR in use and the load. Factory setting: general-purpose SSR voltage value.
- Internal connection of MV1 (CH1 MV) and MV2 (CH2 MV), and output 1 and output 2 can be selected in setup data C44.
- 4 to 20 mA dc and 0 to 20 mA dc can be selected in setup data C90.

■ Heat/cool output (5K)

Connect as follows.

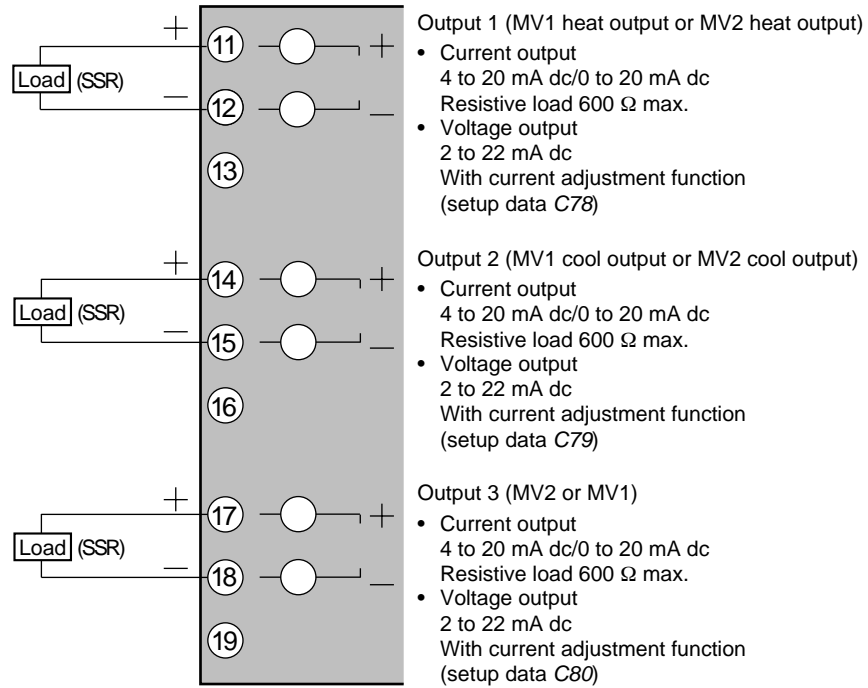

! Handling Precautions

- Current output and voltage output can be selected by setup data C75, C76 and C77.
Voltage output is reliant on an internal fixed-current circuit.
Set the current value in the setup data so that the optimum voltage is obtained matched to the conditions of the SSR in use and the load.
Factory setting: general-purpose SSR voltage value.
- Internal connection of MV1 (CH1 MV) and MV2 (CH2 MV), and output 1 and output 2 can be selected in setup data C44.
- 4 to 20 mA dc and 0 to 20 mA dc can be selected in setup data C90.

4 - 9 Connecting auxiliary outputs (outputs 3)

WARNING



Before wiring the DCP302, be sure to turn the power OFF.
Failure to do so might cause electric shock.

■ 0D, 5G auxiliary outputs

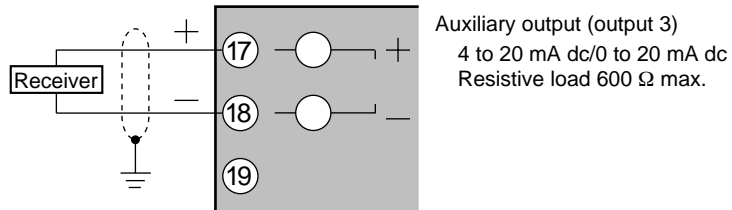

Handling Precautions

- Use shielded cable only.
- 2G, 3D or 5K models do not support auxiliary output.
- 4 to 20 mA dc and 0 to 20 mA dc can be selected in setup data C90.

4 - 10 Connecting Event Output (relay output)

Event outputs EV1 and EV2 are 1a contact, and event output EV3 is 1a1b. Event outputs are connected on the standard terminal base.

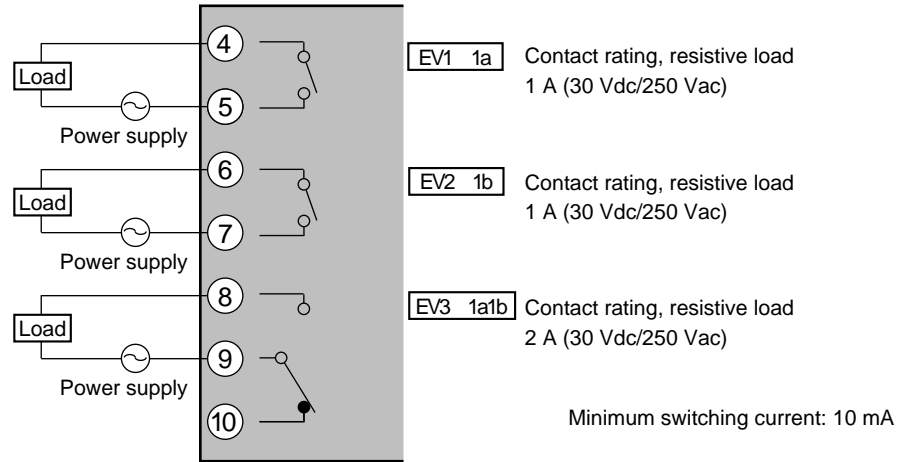

! Handling Precautions

When switching small currents, connect a bleeder resistor to allow current flow of the minimum relay switching input (10 mA min.).

4 - 11 Connecting Time Event Output (open-collector)

Optional time event outputs T1 to T5 (open-collector outputs) can be added on. Time event outputs are connected on the add-on terminal base.

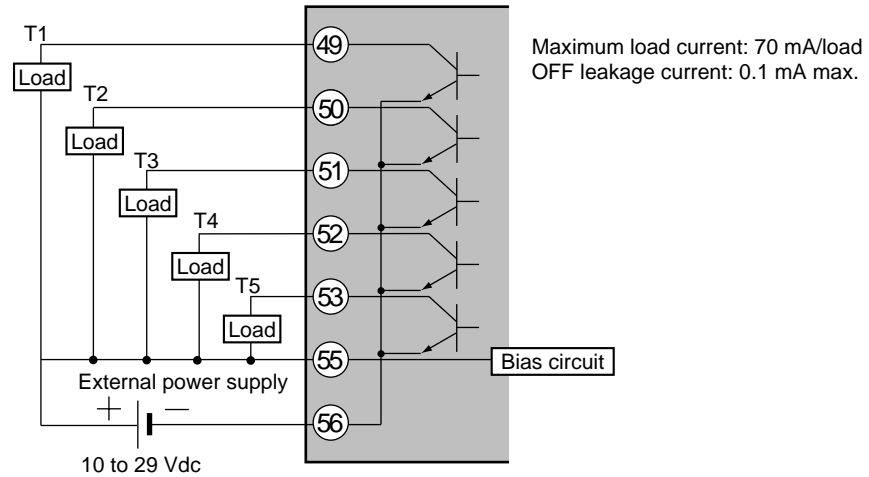

! Handling Precautions

- Be sure to connect terminal 55 to the + terminal of the external power supply. Otherwise, open-collector output will not function.
- Do not short-circuit the + terminal of the external power supply and terminals 49 to 53 on the DCP302. Doing so will cause faulty open-collector output.
(The DCP302 does not contain a short-circuit prevention circuit.)
- When connecting to a semiconductor load such as a programmable controller (sequencer), select a module whose current directions are matching.
Use a module that does not operate by leakage current when the open-collector output of the DCP302 is OFF.

4 - 12 Connecting External Switch (RSW) Input

The DCP302 is provided with four standard and eight optional external switch inputs.

The optional eight inputs are located on the add-on terminal base. In this case, wire the external switch inputs across the standard and add-on terminal bases.

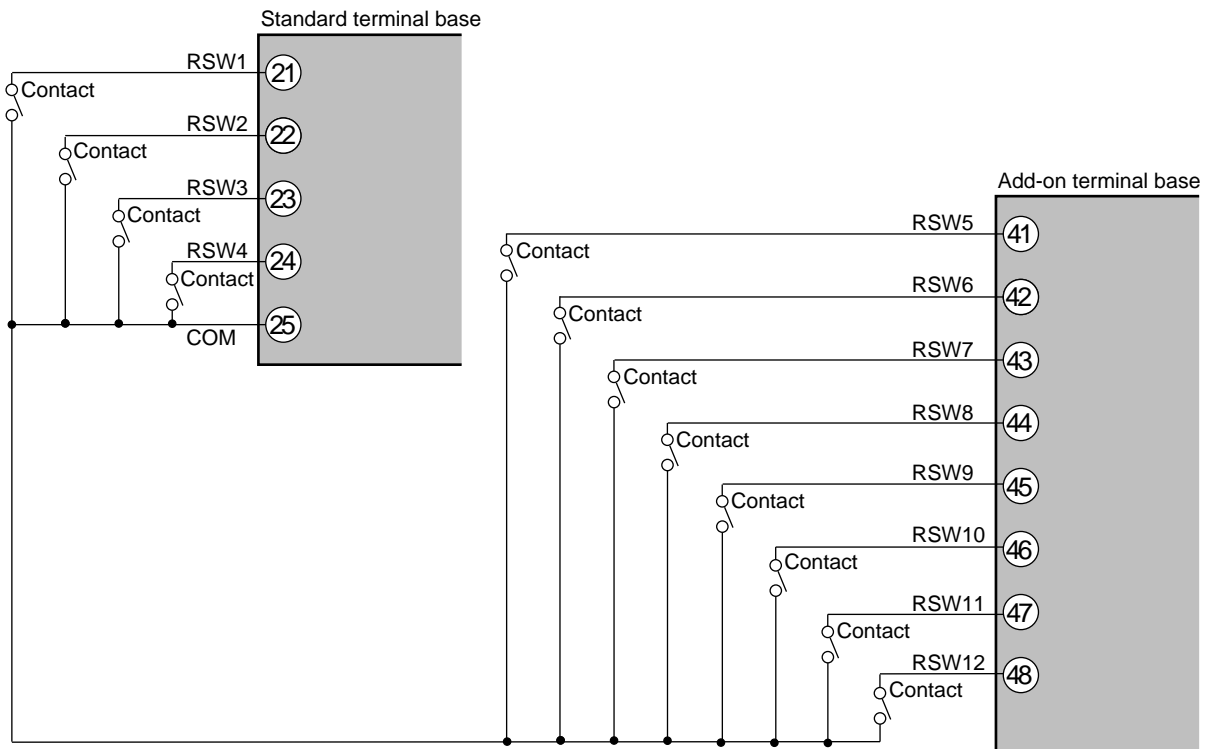

! Handling Precautions

- The external switch inputs on the DCP302 have built-in power supplies (open voltage 12Vdc). Be sure to use no-voltage contacts for external contacts.
- Use no-voltage contacts such as gold contacts whose small current can be switched ON/OFF. On some relay contacts, the small current cannot be switched ON/OFF. Use no-voltage contacts having a sufficient minimum switching capability with respect to the contact current and open voltage of the DCP302.
- When using a semiconductor (e.g. open-collector) as a no-voltage contact, use a semiconductor whose contact terminal voltages at contact ON are 3V max., and whose leakage current at contact OFF is 0.1 mA.
- External switch inputs on the DCP301/302, can be connected in parallel. When connecting in parallel with other controllers, thoroughly check the conditions of the other controller before configuring the control system.

● Internal circuit for controller components for connecting external switch inputs

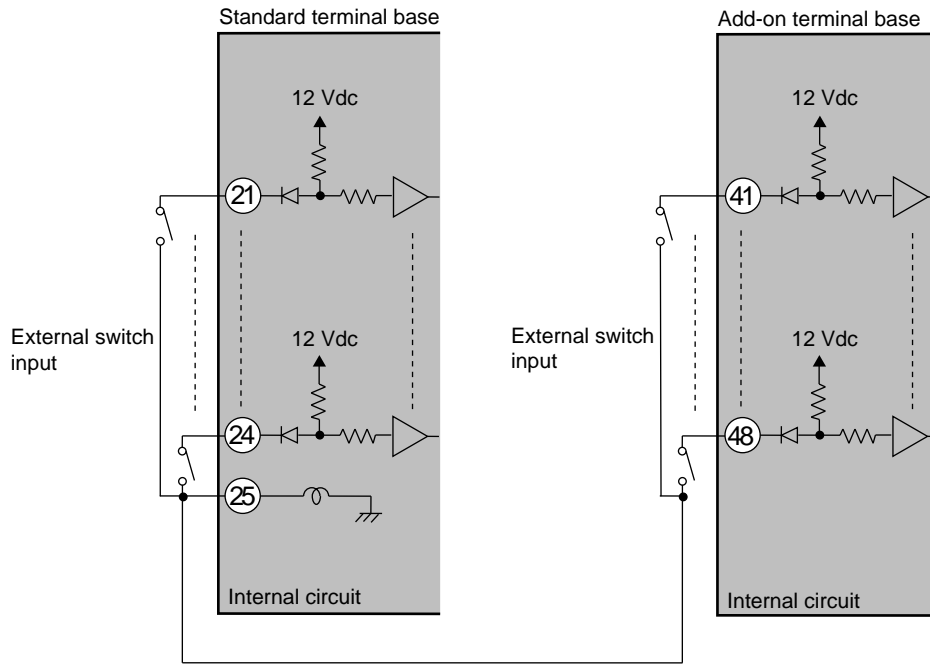

4 - 13 Connecting for Communications

Some controller models support the RS-485 communications interface. Select the RS-485 communications models by selecting the required model No.

The DCP302 operates as a slave station in a multidrop configuration. In this case, connect as follows.

■ RS-485 interface

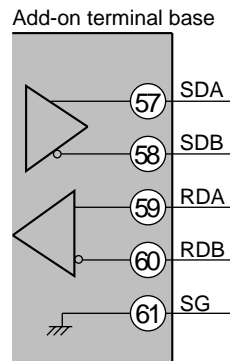

! Handling Precautions

- Make sure that different addresses are set for each slave station.
- Provide terminators (total of 4 in the case of a 5-lead connection) on both ends of the communications path.
Use terminators having a resistance of $150\ \Omega \pm 5\%$, 1/2 W min.
- In the case of a 3-lead connection, short-circuit terminals 57 and 59, and 58 and 60 on the DCP302.
- Do not short-circuit 57 and 58, or 59 and 60 terminals.
Doing so might damage the DCP302.

● 5-lead RS-485 mutual connection

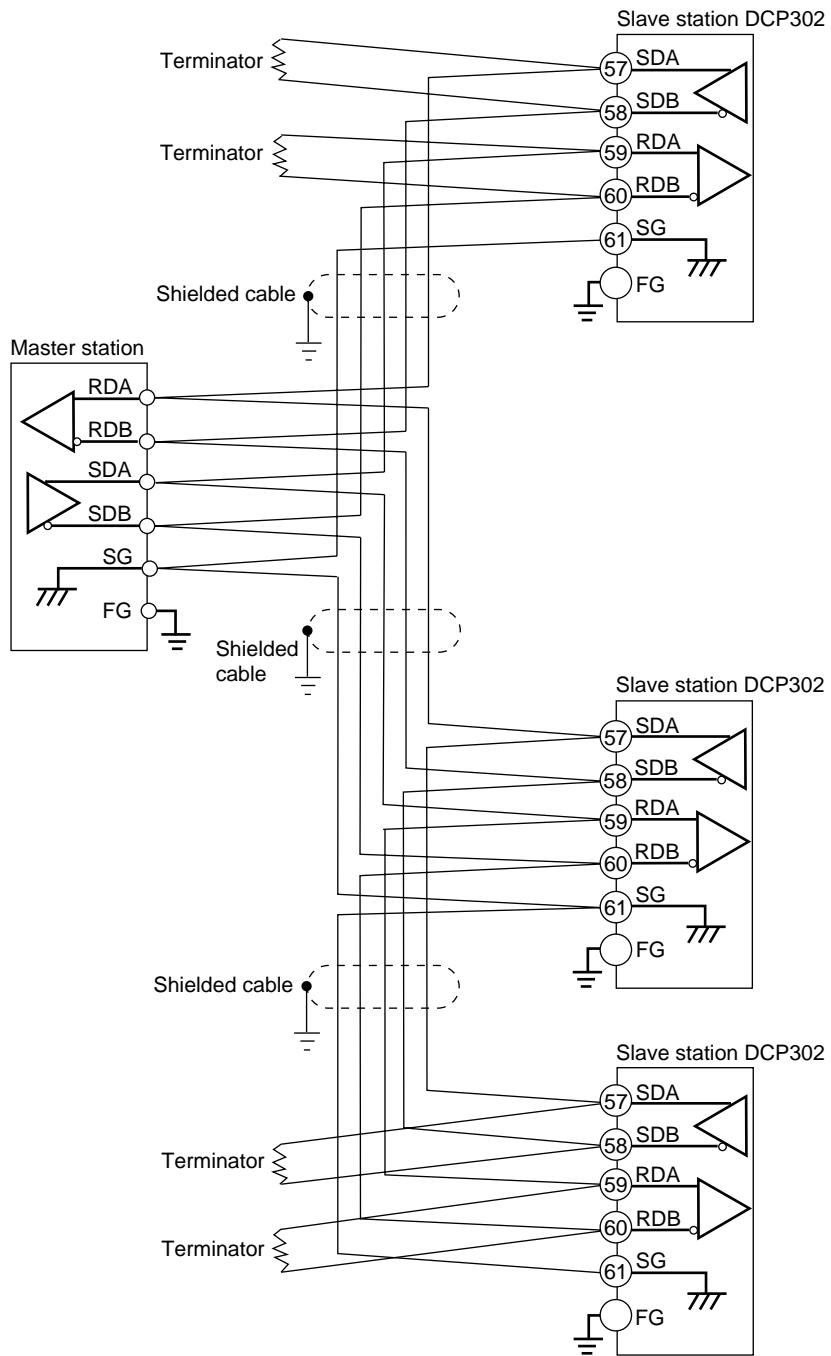

Provide terminators of resistance $150 \Omega \pm 5\%$, 1/2 W min. at both ends of the communications path.

Grounding of the shielded FG terminal should be carried out at only one end and not both ends.

● 3-lead RS-485 mutual connection

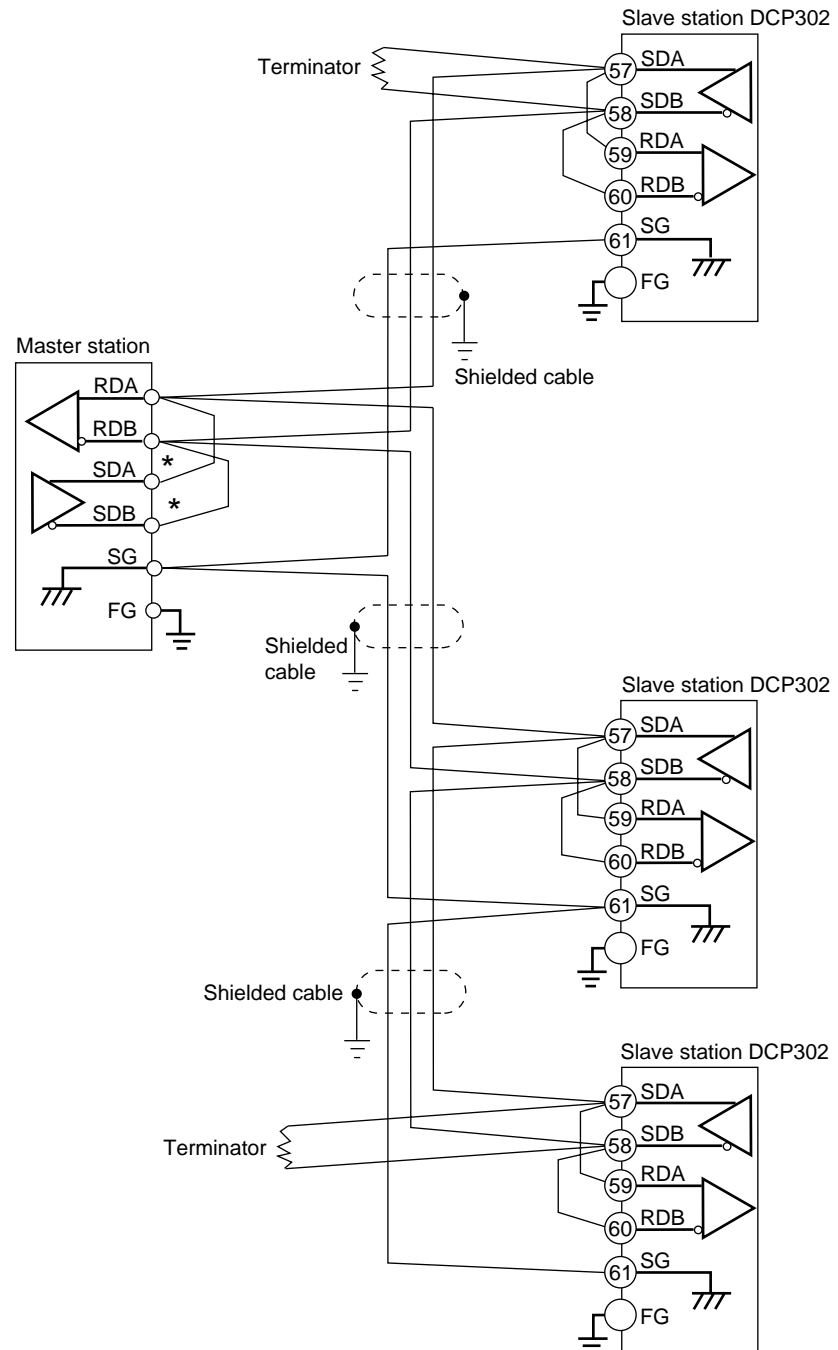

Provide terminators of resistance $150\ \Omega \pm 5\%$, $1/2\ W$ min. at both ends of the communications path.

Grounding of the shielded FG terminal should be carried out at only one end and not both ends.

When there are only three RS-485 terminals, terminals marked * are wired internally.

4 - 14 Isolating Inputs and Outputs

The following figures show isolation between inputs and outputs. Solid lines show isolated items, and dotted lines show non-isolated items.

■ Control outputs 0D, 5G, 3D, 5K

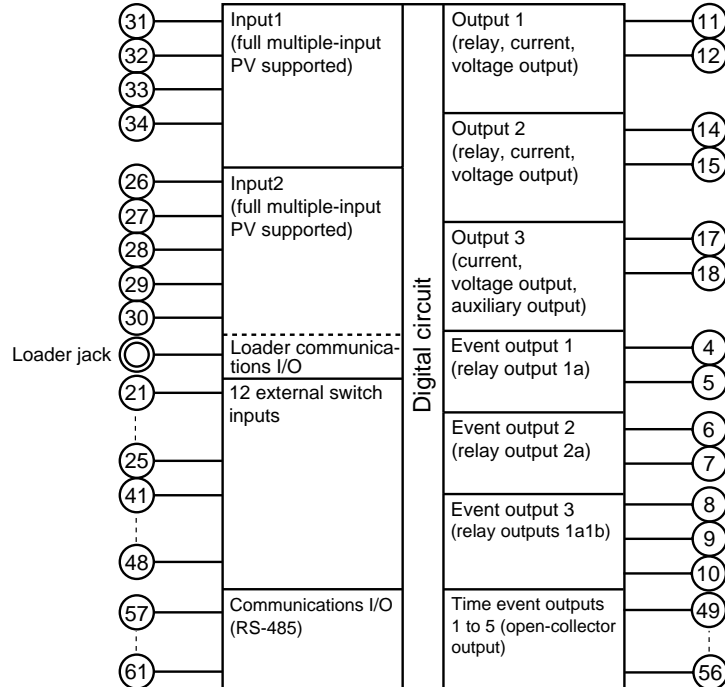

! Handling Precautions

The loader jack is not isolated from internal digital circuits. Be sure to cap the loader jack when it is not in use.

■ Control output 2G

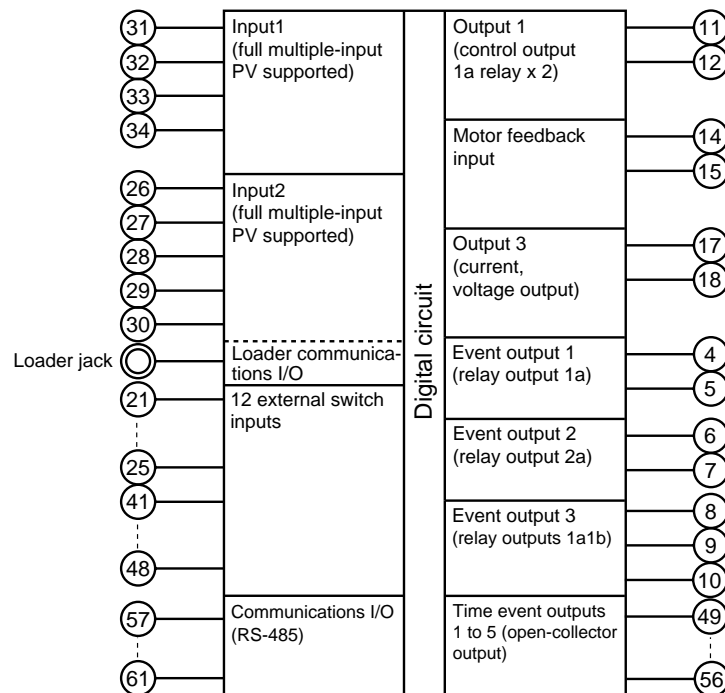

! Handling Precautions

The loader jack is not isolated from internal digital circuits. Be sure to cap the loader jack when it is not in use.

Chapter 5. FUNCTIONS

5 - 1 Data

■ Data types

The DCP302 supports the following data types.

For further details, see Chapter 7, Parameter Setup and Chapter 8, Program Setup.

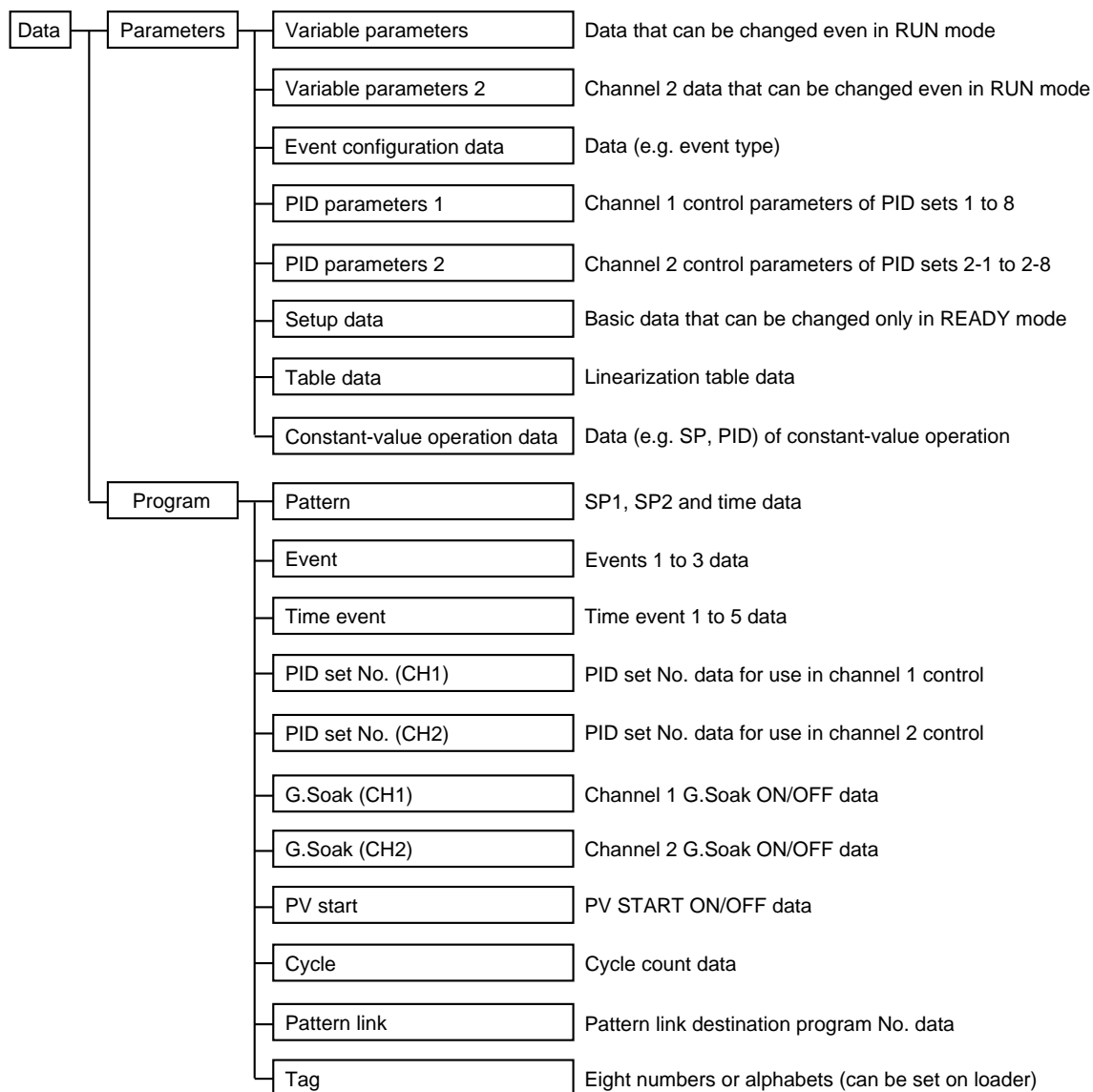

5 - 2 Program Patterns

■ Patterns

SP1 (SP of CH1), SP2 (SP of CH2) and time comprise the settings for a single segment in a pattern.

Up to 30 segments can be linked to create a broken-line whose vertical axis is SP and horizontal axis is time.

This system is called the “RAMP-X” system.

SP1 setting: Within range of SP1 limiter upper and lower limits

SP2 setting: Within range of SP2 limiter upper and lower limits

Time setting: 0 to 99 hours, 59 minutes or 0 to 99 minutes, 59 seconds
(Select the time unit in setup data C64.)

SP is the point that corresponds to the time elapsed in the current segment on a straight line made by joining the start point (SP setting value of the previous segment) to an end point (SP setting value of the current segment).

Accordingly, segments are categorized as follows:

- Rising ramp (rising ramp, rising tendency)
Previous segment SP setting value < current segment SP setting value
- Falling ramp (falling ramp, falling tendency)
Previous segment SP setting value > current segment SP setting value
- Soak (soak)
Previous segment SP setting value = current segment SP setting value

In the case of the No.1 segment, both the start and end points become the soak segment of the No.1 segment SP setting values.

SP (other than No.1 segment) is calculated by the following formula:

$$\text{SP} = (\text{current segment SP setting value} - \text{previous segment SP setting value}) \times (\text{current segment elapsed time} \div \text{current segment time setting}) + \text{previous segment SP setting}$$

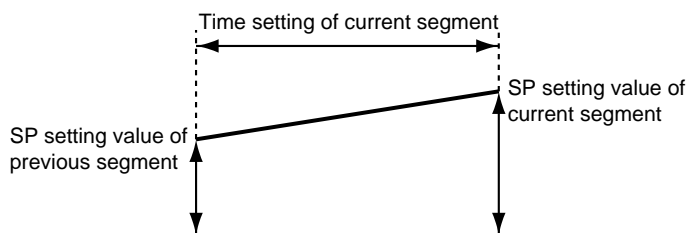

Time setting is common to both SP1 and SP2.

■ Events 1 to 3

Events 1 to 3 are event configuration data. These are used after the event type, event standby, hysteresis and ON delay time are set.

A total of three event types are available: PV type events, controller status events and time events.



● PV type events

- Basic specifications

The following page shows event type PV, deviation, absolute value deviation, SP, MV and MFB. In the figures, the thick lines show ON-OFF changes in state. The upper line expresses the ON state, and the lower line the OFF state. EV and H stand for event setting value and hysteresis, respectively. Output in the READY state is OFF.

- Event standby

Events function as follows when event standby has been set to ON.

- If the DCP302 is in the  state in the figure when changing from the READY to the RUN mode and after restoring the power, operation is the same as when event standby is set to OFF. The up-facing arrow in the figure indicates a change to ON, and a down-facing arrow indicates a change to OFF.
- If the DCP302 is outside the  state in the figure when changing from the READY to the RUN mode and after restoring the power, the state is OFF. After entering the  state, the up-facing arrow in the figure indicates a change to ON, and a down-facing arrow indicates a change to OFF.

- Event ON delay

The event No. to apply the delay to and the delay time can be set regardless of event type. “Delay” functions to turn output ON when the event is continuously ON for the preset delay time after the event OFF → ON condition is satisfied. When event ON delay is combined with event standby, event standby must first be canceled before event ON delay functions.

- Segment progression

- Output is OFF until the program progresses to a segment containing the event setting.
- When the program progresses to a segment containing an event setting, event ON/OFF operation is carried out according to the event setting value.
- The previous setting is valid until the program progresses to a segment containing a new event setting. Accordingly, set as follows to disable the event set to the preceding segment from a certain event onwards:

Direct action events: Upper limit value of event setting

Reverse action events: Lower limit value of event setting

However, note that with some event types the event sometimes turns ON even if you set as shown above.

- When the program has progressed to the No.1 segment by the cycle or pattern link functions, the previous setting is disabled. Output is OFF unless the No.1 segment contains an event setting.

- Other

When CH1 side output is current output other than heat/cool output, setup data C18 is set to 1, and SP output (programmer functions) is selected, the MV1 direct/reverse event does not function.

When CH2 side output is current output other than heat/cool output, setup data C41 is set to 1, and SP output (programmer functions) is selected, the MV2 direct/reverse event does not function.

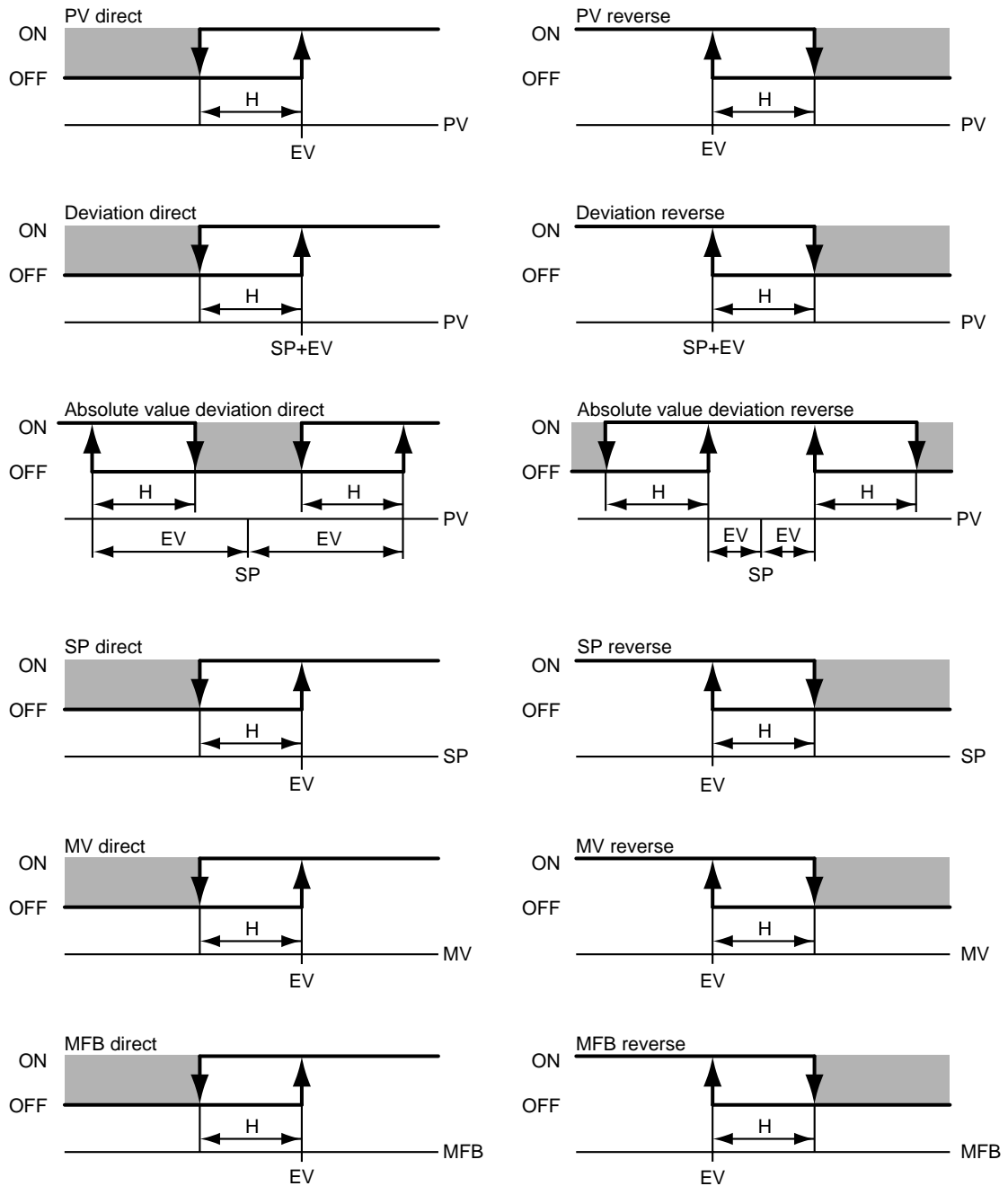

● Controller status events

Controller status events are turned ON and OFF according to the DCP302 mode, alarm status and other statuses.

Though the event standby function does not function, the ON delay function does. Event setting values (operating point), hysteresis and event standby are not set.

- Basic operations

The following event types are provided:

RUN+HOLD+FAST+END

READY

RUN

HOLD

FAST

END

G.Soak standby (logical OR of CH1 and CH2, CH1, CH2)

MANUAL (logical OR of CH1 and CH2, CH1, CH2)

Auto-tuning executing (logical OR of CH1 and CH2, CH1, CH2)

Constant-value operation

MFB estimated position control

Logical OR of all alarms

PV range alarm

Controller alarms

Low battery voltage

Console setup in progress

Loader setup in progress

ADV

When the DCP302 reaches the state designated by the event type, the event is turned ON. Otherwise, the event is OFF.

- Alarms

Alarms are divided into the PV range alarm group (alarm code Nos. 01 to 16) and the controller alarm group (alarm code Nos. 70 to 99, and low battery voltage).

When the event type is set to the logical OR of all alarms, the alarm turns ON even if at least one of the alarms occurs.

When the event type is set to PV range alarm, the alarm turns ON even if at least one of the alarms in the PV range alarm group occurs.

When the event type is set to controller alarm, the alarm turns ON even if at least one of the alarms in the DCP302 alarm group occurs.

- ADV

This is ON for one second after executing program advance. The event ON delay setting is also enabled.

● Time events

When the event 1 to 3 type is set to time event, the event can be used in the same way as time events 1 to 5. However, note that events 1 to 3 do not have segment No. event functions.

Though the event standby function does not function, the ON delay function does.

■ Time events 1 to 5

Either of time events or segment No. events can be selected by the time event type item in the event configuration data setup.

● Time events

The ON and OFF times or only the ON time can be set for each event No. and segment. The following describes ON/OFF of output.

- When the ON time is smaller than the OFF time, output is ON for the duration from the ON time to the OFF time.

(See segments 1, 6 and 7 in the figure.)

- When only the ON time is set, output is ON for the duration from the ON time to the segment end point.

(See segments 2 and 5 in the figure.)

- When neither the ON time nor OFF time are set, output is OFF.

(See segment 3 in the figure.)

- Setting only the OFF time without an ON time is not possible.

(See segment 3B in the figure.)

- Setting an ON time to be greater to or equal than the OFF time is not possible.

(See segment 3C in the figure.)

- Only ON and OFF times set within the segment time are valid. Times straddling the next segment are invalid. The ON and OFF times set in the next segment are valid.

(See segments 4 and 5 in the figure.)

Accordingly, the ON and OFF times settings at the segment end point are ignored.

However, ON and OFF times set for segment end points when the END mode is moved to are valid.

(See segment 9 in the figure, and compare with segment 10 in the END mode.)

- When the ON time is set to 0 (no OFF time setting, or OFF time is greater than 0), output becomes OFF at time 0.

If output at the previous segment end point was ON at this time, the output status at the segment switching point does not momentarily become OFF.

(See segments 5 and 6 in the figure.)

- The G.Soak standby time is not included in the ON and OFF times.

(See segment 7 in the figure.)

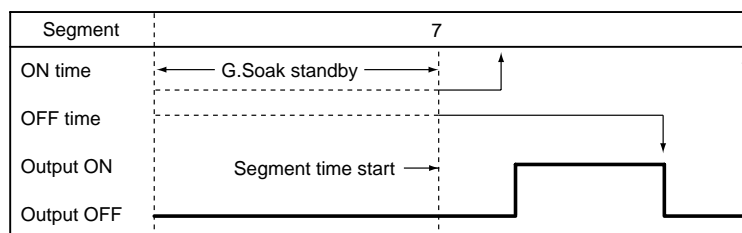
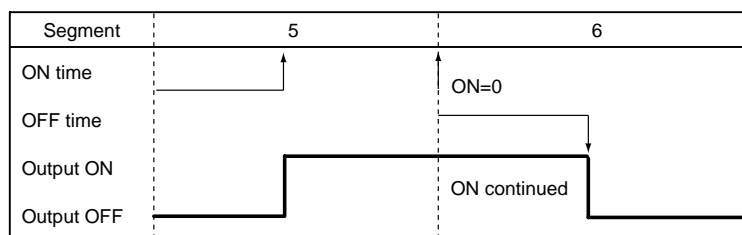
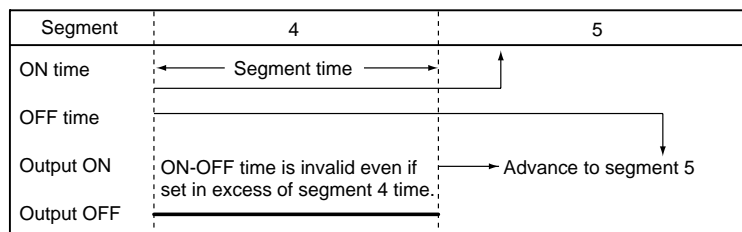
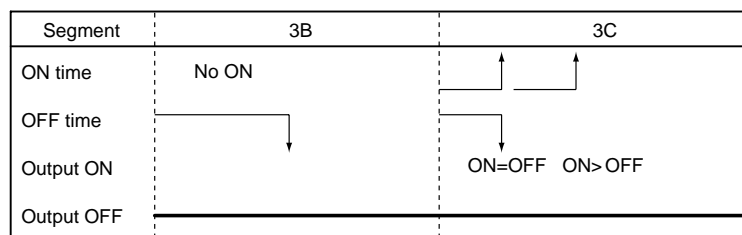
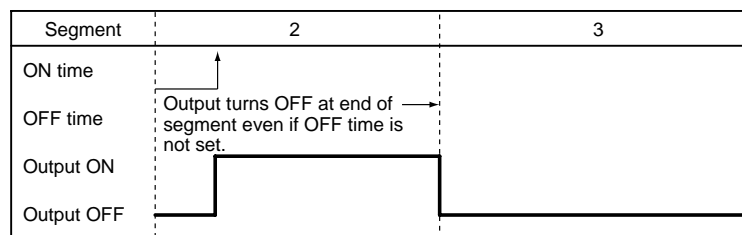
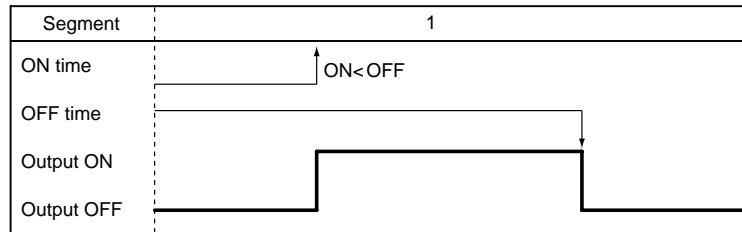

- If the ON time is set to 0 in the case of G.Soak standby, output becomes ON from the G.Soak standby state, and the ON time is started at completion of the G.Soak standby time.
The output time = G.Soak standby time + OFF time
(See segment 8 in the figure.)
- ON and OFF time settings the same time as the segment end point are valid in the case of the final segment END mode.
(See segment 10 in the figure.)

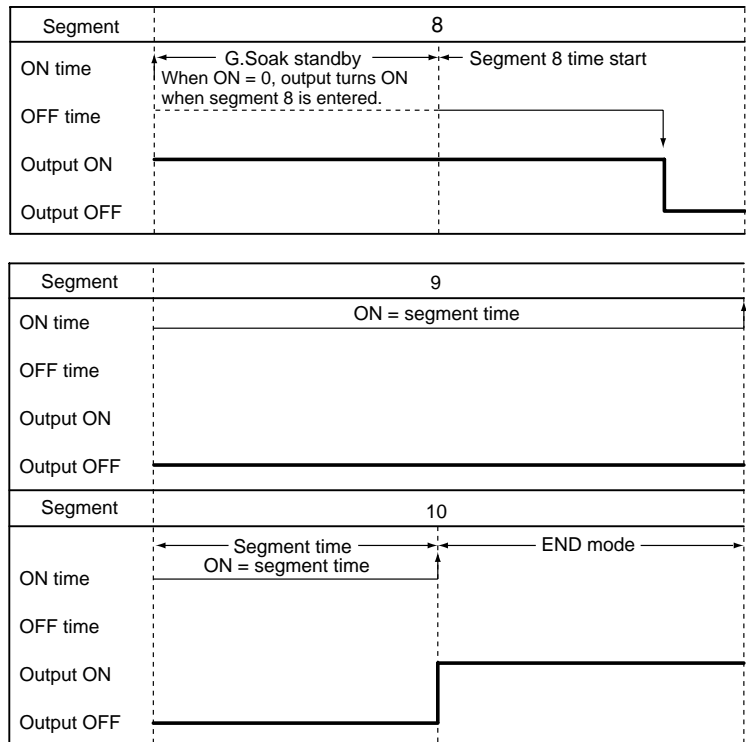

● Segment No. events

The current segment No. is output as binary code.

When all of T1 to T5 are selected as segment No. events in the time event type setup, all ON-OFF operations are as shown in the following table.

When T1 to T4 are assigned partially to segment No. events, only the assigned time events operate as shown in the following table, and the remaining events operate as regular time events.

Segment No. / Event No.	1	2	3	4	5	6	7	8	9	10	11	12	13	14	15
T1	ON	OFF	ON	OFF	ON	OFF	ON	OFF	ON	OFF	ON	OFF	ON	OFF	ON
T2	OFF	ON	ON	OFF	OFF	ON	ON	OFF	OFF	ON	ON	OFF	OFF	ON	ON
T3	OFF	OFF	OFF	ON	ON	ON	ON	OFF	OFF	OFF	OFF	ON	ON	ON	ON
T4	OFF	OFF	OFF	OFF	OFF	OFF	OFF	ON	ON	ON	ON	ON	ON	ON	ON
T5	OFF	OFF	OFF	OFF	OFF	OFF	OFF	OFF	OFF	OFF	OFF	OFF	OFF	OFF	OFF

Segment No. / Event No.	16	17	18	19	20	21	22	23	24	25	26	27	28	29	30
T1	OFF	ON	OFF	ON	OFF	ON	OFF	ON	OFF	ON	OFF	ON	OFF	ON	OFF
T2	OFF	OFF	ON	ON	OFF	OFF	ON	ON	OFF	OFF	ON	ON	OFF	OFF	ON
T3	OFF	OFF	OFF	OFF	ON	ON	ON	ON	OFF	OFF	OFF	OFF	ON	ON	ON
T4	OFF	OFF	OFF	OFF	OFF	OFF	OFF	OFF	ON	ON	ON	ON	ON	ON	ON
T5	ON	ON	ON	ON	ON	ON	ON	ON	ON	ON	ON	ON	ON	ON	ON

■ PID set selection

- Eight sets of PID parameters, PID1 to PID8 for CH1 and PID2-1 to PID 2-8 for CH2, are used for control operation. When the PID set No. is set to each segment by designating the PID set segment, control output is calculated by each of the PID parameters.
- There are two ways of selecting PID sets: by designating the PID set segment and by PID set auto-switching. The method can be selected by setting setup data *C11* or *C34*.
C11 set to 0: Designation of CH1 PID set segment
C11 set to 1: CH1 PID set auto-switching
C34 set to 0: Designation of CH2 PID set segment
C34 set to 1: CH2 PID set auto-switching

These two methods cannot be set simultaneously in PID set selection on the same channel.

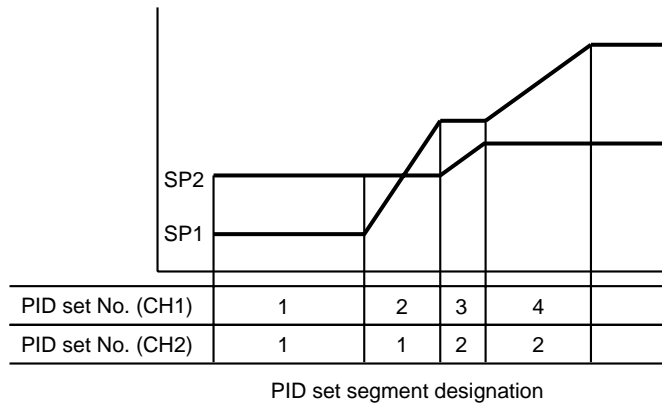

Note

When setup data *C11* is set to 1, PID set No. items (CH1) in the program setup are not displayed.

When setup data *C34* is set to 1, PID set No. items (CH2) in the program setup are not displayed.

- By designation of PID set segment, the PID set No. is set for each segment, and control output is calculated by each of the PID parameters.
- By PID set auto-switching, the SP full-scale is divided into eight zones according to the settings of *CP.11* to *CP.17* of CH1 or *CP.21* to *CP.27* of CH2, and the PID constant to be used according to the SP value is automatically selected to calculate the control output.

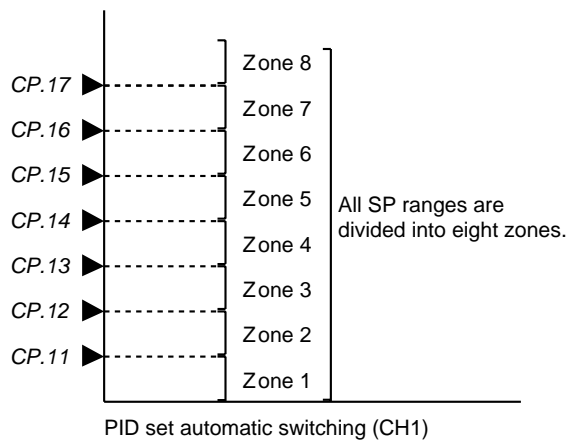

■ G.Soak (guarantee soak)

G.Soak ON/OFF and G.Soak width can be set for each segment. The G.Soak time can also be set by the variable parameter *gs.t* item. The G.Soak function ensures a segment execution time with PV close to SP. G.Soak functions not only in soak segments but also in ramp segments.

At the segment start point, PV and SP are compared, and the absolute value of the resulting deviation continues for the G.Soak time or longer. When the absolute value is smaller than the G.Soak width, operation of that segment is started.

The DCP302 is in the G.Soak standby state until this condition is satisfied, and the line lamp on the left side of the profile display blinks. The operation state is the same as HOLD at the segment start point (time is set to 0).

If G.Soak standby is canceled on both channels when G.Soak is set to ON on channels CH1 and CH2, operation of that segment starts.

However, note that in the FAST mode, the DCP302 does not enter the G.Soak standby state even if G.Soak is set to ON. The G.Soak standby state can also be canceled by external switch output. The following cancel conditions can be used for both CH1 and CH2, and selected by the setup date *C52* to *C54* settings.

- ① G.Soak cancel when external switch input contact is ON or PV satisfies the G.Soak cancel conditions
- ② G.Soak cancel when external switch input contact is ON and PV satisfies the G.Soak cancel conditions

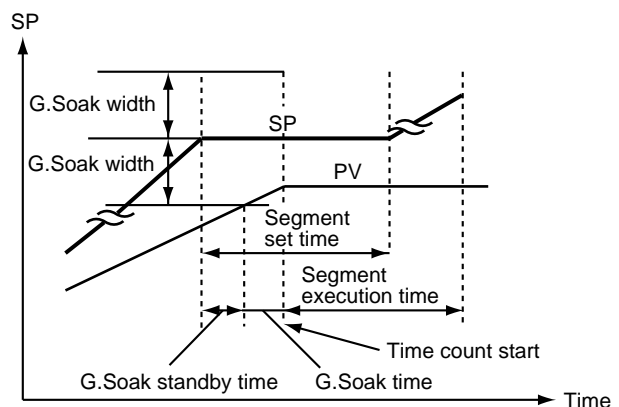

■ PV start

If PV start is set in the program setup, PV is started by regular RUN operation.

The first point where PV matches the SP in the program pattern (including bias for both PV and SP) is searched for, and operation is started from that point.

However, note that if a matching point is not found, operation is started from the beginning of segment 1.

You can select in the program setup which channel, CH1 or CH2, PV and SP is to be used. When PV has started, event operating points and the time of time events are automatically corrected. If the PV start function is selected by setup data C52 to C54 settings relating to external switch input, PV start can be executed without setting PV start in the program setup.

PV start is valid on the segment of the currently selected program, and is invalid on the segment of the pattern link destination.

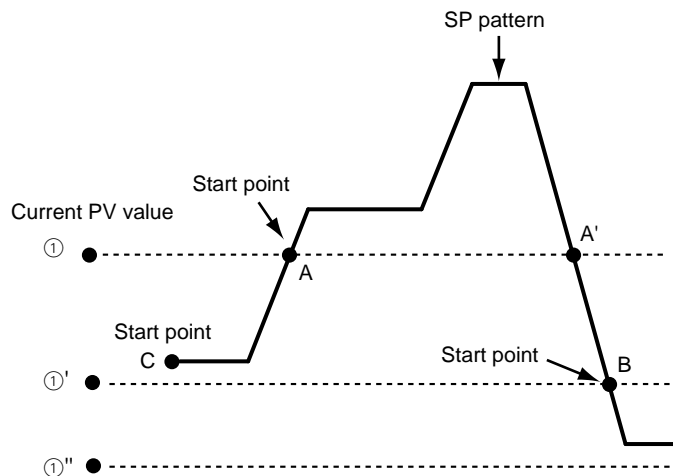

PV start points

- ① PV starts at point A where the PV value first crosses the SP pattern.
- ①' PV starts at point B where the PV value first crosses the SP pattern.
- ①'' Point C of segment 1 is the PV start point since there is no point where the PV value crosses the SP value.

■ Cycle

The cycle function is for repeating operation from the No.1 segment of the program pattern to the final set segment for a preset number of cycles. The number of cycles can be set up to 9999.

When a number of cycles “n” is set, the operation count becomes “n+1”.

When executing cycle operation, operation at the end point of the final segment is not carried out, and operation is restarted with the effective value (setting of previous segment continued) of the program item (e.g. PV event value, PID set No.) whose setting is continuous from the previous segment cleared. At this time, PV is not started and operation starts from the No.1 segment even if PV start is set.

If the SPs at the pattern start and end points do not match, the SP changes in a stepped manner during cycle operation.

Cycle operation functions simultaneously on both patterns of SP1 and SP2.

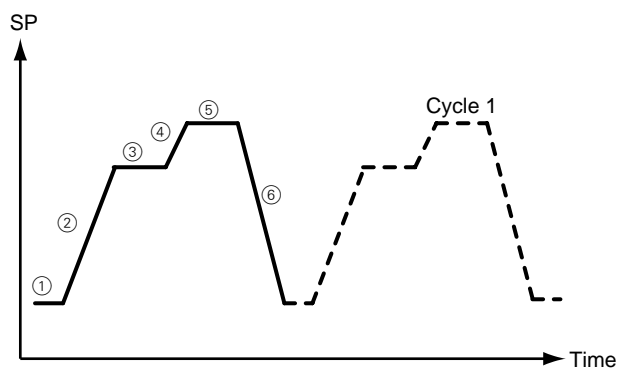

■ Pattern link

“Pattern link” is a function for linking patterns together. The link destination program No. is set by the pattern link item.

When the pattern link item is set to 0 (default), patterns are not linked. When the No. of the current program itself is set to the pattern link item, this creates an endless loop.

If the SPs at the link source end point and the link destination start point do not match, the SP changes in a stepped manner during link operation.

When cycle operation has been set, the pattern link function works after cycle operation has ended. After pattern link operation ends, operation begins from the No.1 segment of the link destination pattern, so operation is restarted with the effective value (setting of previous segment continued) of the program item (e.g. PV event value, PID set No.) whose setting is continuous from the previous segment cleared.

If PV start is programmed to the link destination pattern, the PV start function operates after the link is made.

After the link has been made, PID operation is not initialized, and is continued.

Pattern link functions simultaneously on both patterns of SP1 and SP2.

Pattern linking of program No.2 to program No.1

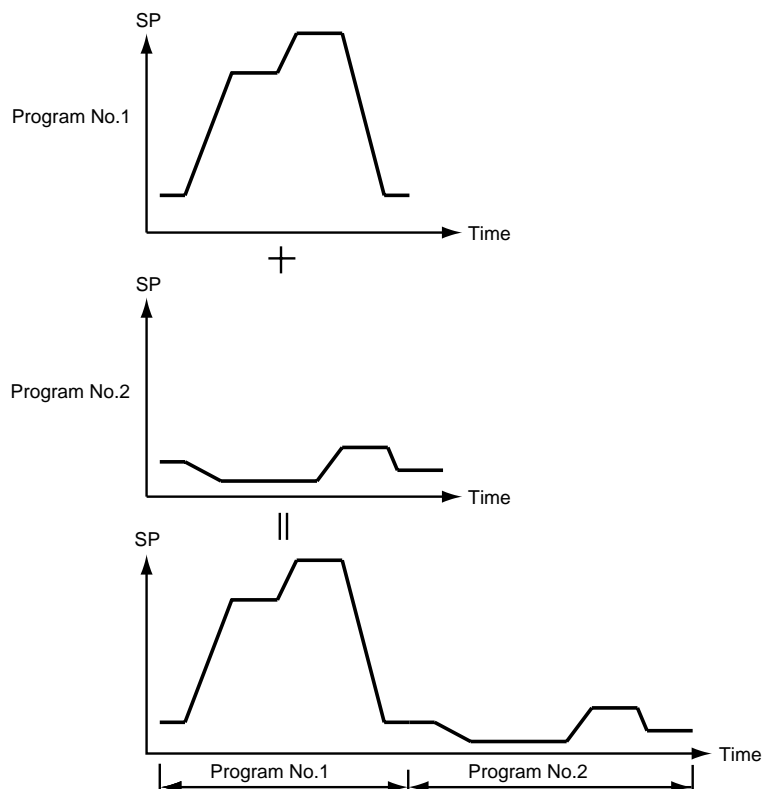

■ Tag

A “tag” is eight alphanumeric data that can be set to each program.

Though this item cannot be displayed nor set on the DCP302, it can be displayed and set on the smart loader package.

When the pattern items of segment 1 has been set by program setup, a total of eight characters (“PROG” + program No. (2 characters) + “_” (two spaces)) are automatically set.

Example:

In the case of program No.1: “PROG01_”

In the case of program No.19: “PROG19_”

5 - 3 Modes

■ Mode types

The following modes are available on the DCP302.

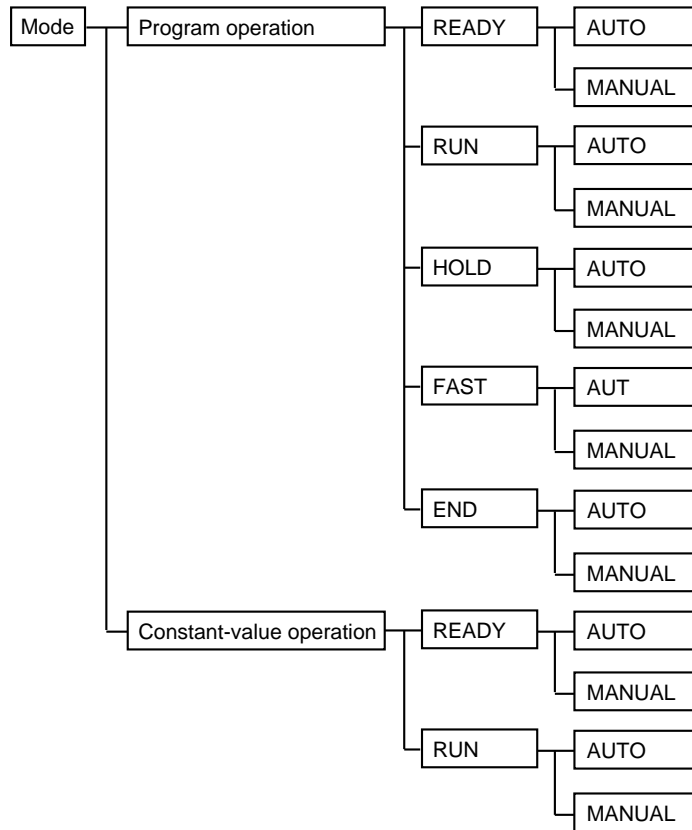

● Program operation

The DCP302 operates according to SP, times, events, etc. set to program patterns No.1 to 19.

● Constant-value operation

The DCP302 operates according to SP or events set in the constant-value operation data. Time events 1 to 5 turn OFF.

● READY

In this mode, the DCP302 is ready for operation.

MV output is fixed, and events to be operated according to event setting values turn OFF. However, events to be operated according to controller states are active. Parameters for all of the setup data, some event configuration data and some constant-value operation data can be set or changed only in the READY mode. During program operation, program pattern Nos.1 to 19 can be selected.

● RUN

In this mode, the program is running.

MV outputs are active in PID control, and events and time events are active.

In the program operation mode, program operation progresses according to the elapsed time.

However, note that progress of program operation stops in the same way as the HOLD mode when the DCP302 is in the G.Soak (Guarantee Soak) standby state.

● HOLD

In this mode, program operation is held.

Progress of program operation stops. However, note that MV outputs are active in PID control, and events and time events are active in the same way as in the RUN mode.

The HOLD mode is not available during constant-value operation.

● FAST

In this mode, the program is fast-forwarded.

This mode is like the RUN mode except that progress of the program operation time is speeded up.

The time scale is selected by the variable parameter *FAST* setting.

MV outputs are active in PID control or ON-OFF control, and events and time events are active.

The DCP302 does not enter the G.Soak standby state even if G.Soak (Guarantee Soak) is set.

The FAST mode is not available during constant-value operation.

● END

In this mode, operation of the program has ended.

MV outputs are active in PID control or ON-OFF control, and events and time events are active with program operation stopped at the program end point.

The END mode is not available during constant-value operation.

● AUTO

In this mode, program operation is automatic.

MV output is active according to control by the DCP302.

(However, note that when programmer functions are selected on the current output channels except heat/cool, SP output is active according to controller control by the DCP302.)

● MANUAL

In this mode, program operation is manual.

MV output can be changed by ↑, ↓, ←, → on the console or by communications.

(However, note that when programmer functions are selected on the current output channels except heat/cool, SP output can be changed by ↑, ↓, ←, → on the console or communications.)

! Handling Precautions

- The program operation and constant-value operation modes are common to channels CH1 and CH2.
- The READY/RUN/HOLD/FAST/END modes are common to channels CH1 and CH2.
- The AUTO/MANUAL modes are common to channels CH1 and CH2.

■ Mode transition

● **During program operation**

The solid lines in the following diagram show mode transition operations. The broken lines show end of operation.

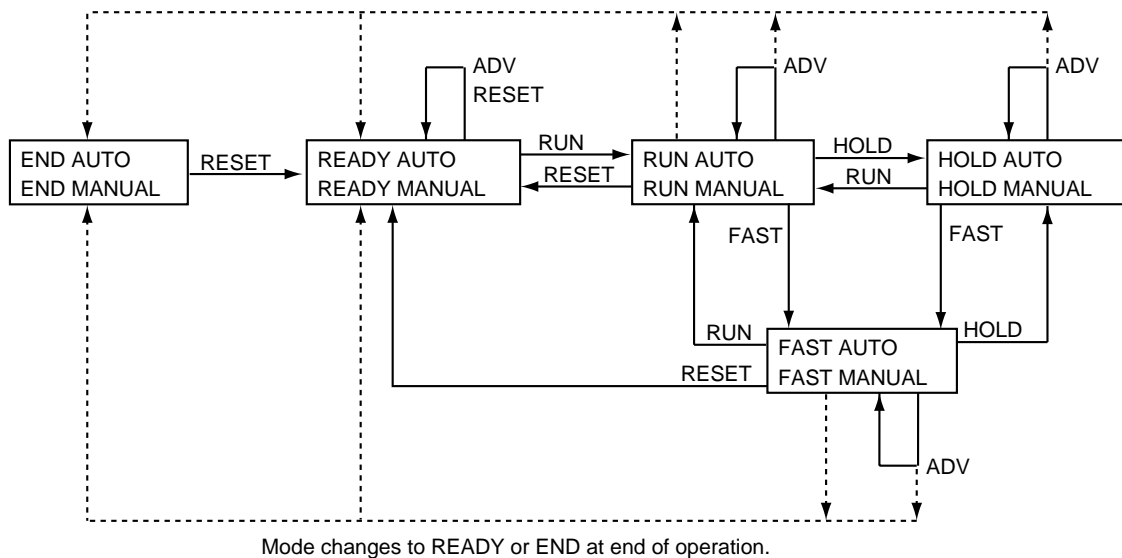

Note

- When moving between the AUTO and MANUAL modes, the modes in the square frames can be moved between.
- Selection of the READY or END modes at end of operation is set up in the setup data.

● **During constant-value operation**

The solid lines in the following diagram shows mode transition operation.

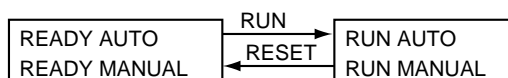

Note

When moving between the AUTO and MANUAL modes, the modes in the square frames can be moved between.

● **Switching between program operation and constant-value operation**

In the READY mode, select operation by the constant-value operation data “*modE*” operation mode item.

- 0: Program operation
- 1: Constant-value operation

■ Mode transition operations

The following describes mode transition operations.

Though "program end" is not an operation, it is described below as it is a factor in mode transition.

● RUN

This operation involves moving to the RUN mode from the READY, HOLD or FAST modes. To move from the READY mode to the RUN mode, the DCP302 must be in the basic display state even in key, external switch input or communication operations.

● HOLD

This operation involves moving to the HOLD mode from the RUN or FAST modes.

The HOLD mode is not available in the constant-value operation mode.

● RESET

This operation involves moving to the READY mode from the RUN, HOLD, FAST or END modes.

In the program operation mode, this mode includes returning to the No.1 segment.

● ADV

This operation involves advancing one segment in the READY, RUN, HOLD or FAST modes.

The ADV mode is not available in the constant-value operation mode.

● FAST

This operation involves moving to the FAST mode from the RUN or HOLD modes.

The FAST mode is not available in the constant-value operation mode.

● AUTO

This operation involves moving to the AUTO mode from the MANUAL mode of the displayed channel.

● MANUAL

This operation involves moving to the MANUAL mode from the AUTO mode for the displayed channel.

When the DCP302 enters the MANUAL mode, the basic display state changes as follows.

- When controller functions are selected, PV and output value (%) are displayed.
- When programmer functions are selected, PV and SP are displayed.

When the DCP302 enters the MANUAL mode from the AUTO mode by external switch inputs or communications, the display changes to the basic display state even in the parameter setup or program setup states.

However, note that when SPw programmer functions are selected, PVw and SPw are displayed on the CH2 display on a temperature/humidity operation model if variable parameter 2 *CH.2* setting is 2. If the setting is other than 2, the basic display does not change.

● Program end

When operation progresses in the RUN or FAST modes in the program operation mode, or when the segment has been advanced in the ADV mode, the program ends when all end points in the program setup including cycles and pattern links have been reached.

You can select in the setup setting in which of the READY or END modes program operation ends.

The program does not end in the constant-value operation mode.

■ Mode transition limitations

Mode transition can be carried out by operating the console keys, external switch input and communications. The following table shows which operations are enabled in each of the modes.

Operation		RUN (to RUN mode)			HOLD (to HOLD mode)			RESET (to READY mode)			ADV (to next segment)			FAXT (to FAST mode)		
		Key	Switch	com-	Key	Switch	com-	Key	Switch	com-	Key	Switch	com-	Key	Switch	com-
Program operation	READY	⊙	⊙	⊙	—	—	—	—	Δ	Δ	—	○	○	—	—	—
	RUN	—	—	—	⊙	○	○	⊙	○	○	⊙	○	○	⊙	○	○
	HOLD	⊙	○	○	—	—	—	⊙	○	○	⊙	○	○	⊙	○	○
	FAST	⊙	○	○	—	○	○	⊙	○	○	⊙	○	○	—	—	—
	END	—	—	—	—	—	—	⊙	○	○	—	—	—	—	—	—
Constant	READY	⊙	○	○	—	—	—	—	—	—	—	—	—	—	—	—
	RUN	—	—	—	—	—	—	⊙	○	○	—	—	—	—	—	—

Operation		MANUAL (to MANUAL mode)			AUTO (to AUTO mode)		
		Key	Switch	com-	Key	Switch	com-
Program operation	AUTO	⊙	○	○	—	—	—
	MANUAL	—	—	—	⊙	○	○
Constant	AUTO	⊙	○	○	—	—	—
	MANUAL	—	—	—	⊙	○	○

- : Operation is enabled.
- ⊙ : Operation is enabled if in basic display state.
- Δ : No.1 segment is returned to if controller is still in READY mode.
- : Operation is disabled.

5 - 4 Controller and Programmer

On the current output channels except heat/cool, you can choose between use of the DCP302 as a controller or a programmer. Set this in setup data *C18* or *C41*.

You can also choose between controller or programmer functions even if the DCP302 is used for program operation or constant-value operation.

Channels on other output models are limited to use as a controller at all times.

● Controller

When the DCP302 is used as a controller, PID control operation is carried out according to PV, SP and PID setting values, and the resulting manipulated variable (MV) is output as an analog output.

Heat/cool PID control and 3-position-proportional is also possible instead of PID control depending on the type of output supported by the DCP302 model.

In the MANUAL mode, the MV can be incremented or decremented in the basic display state by the console keys.

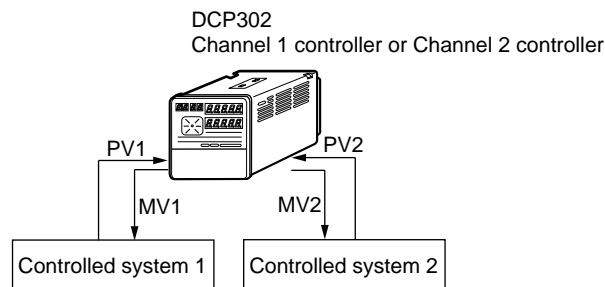

● Programmer

When the DCP302 is used as a programmer, PID control operation is not carried out, and the SP is output in the scaled 4 to 20 mA range.

In the MANUAL mode, the SP can be incremented or decremented in the basic display state by the console keys.

You can also select use of the DCP302 as a programmer on either just one of channels CH1 and CH2 or both channels.

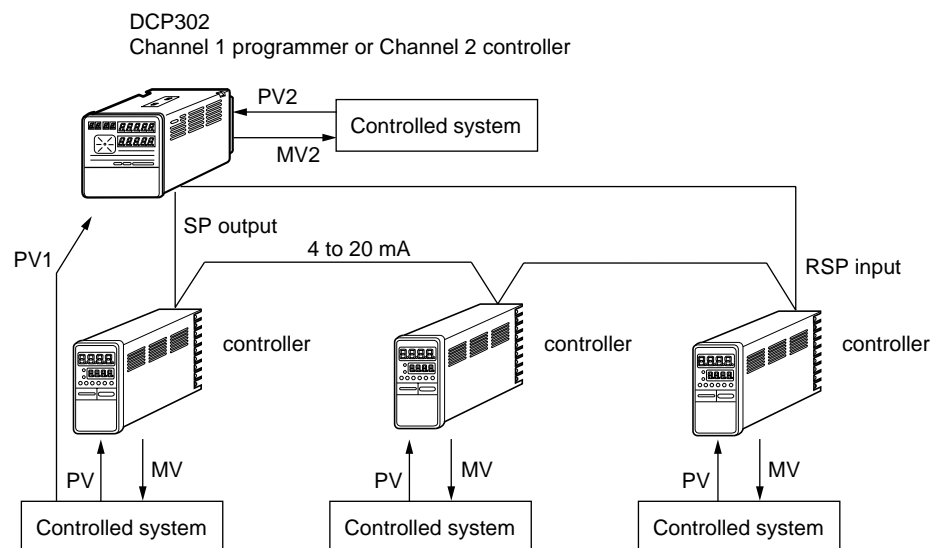

! Handling Precautions

If setup data *C41* has been set to 2 (SPw programmer) on CH2 on a temperature/humidity operation model, set variable parameter 2 *CH.2* to 2 (PVw + SPw additional display) to increment or decrement SPw in the MANUAL mode.

5 - 5 Input Processing Functions

Input 1 processing is carried out in the order shown below:

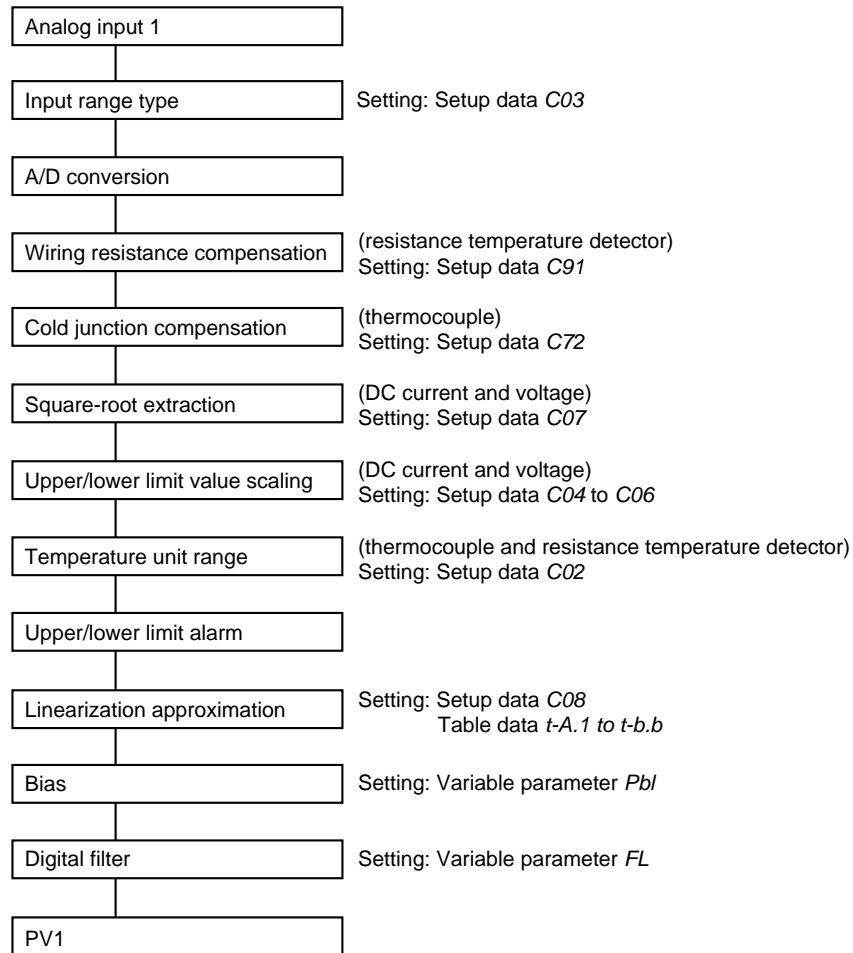

Input 2 processing is carried out in the order shown below:

• Temperature/humidity operation model

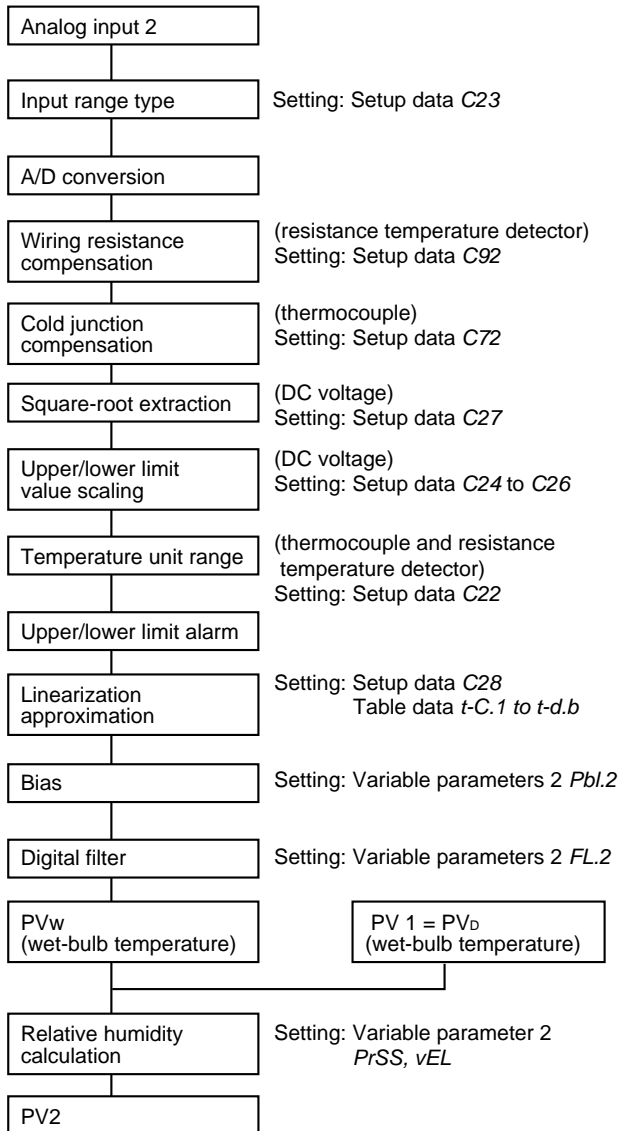

• Input 2 channels model

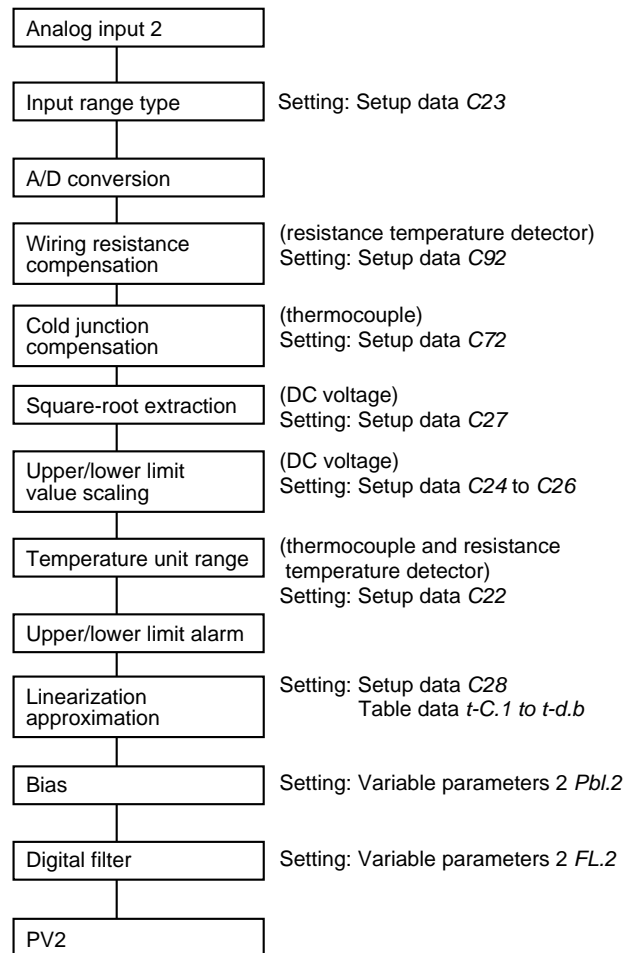

! Handling Precautions

On a temperature/humidity operation model, the humidity channel (CH2) is controlled by wet-bulb set value SPw and wet-bulb temperature PVw. SPw and PVw are automatically converted from SP1 (dry-bulb temperature set value) and SP2 (relative humidity set value).

5 - 6 Output Processing Functions

Three outputs are provided as output processing functions: control output, SP output and auxiliary output.

■ MV1/MV2 switching

MV1 and MV2 according to control output or SP output, and outputs 1, 2 and 3 can be switched as shown in the figures below. (Processing in these figures advances from left to right.)

● 0D, 5G output

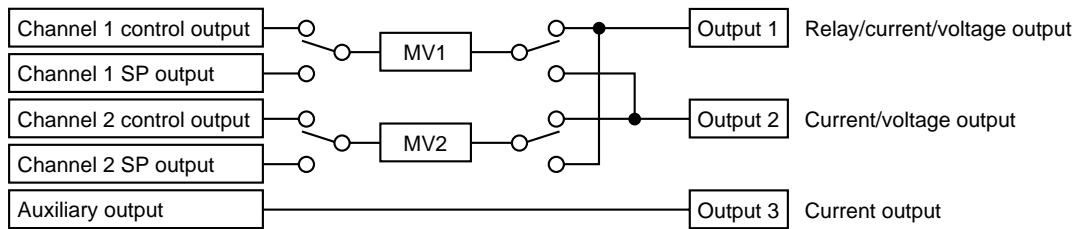

● 2G output

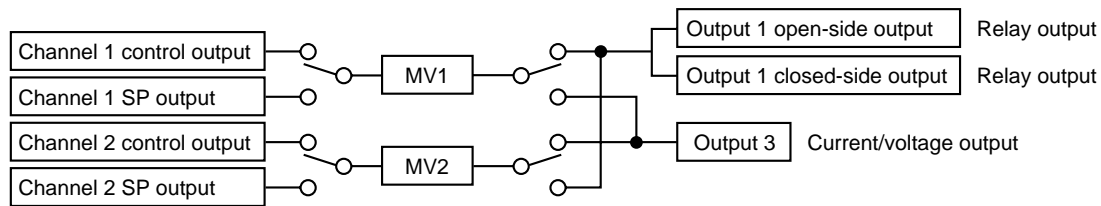

● 3D, 5K output

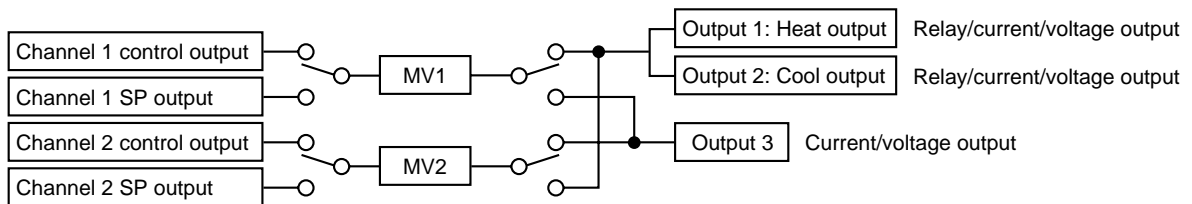

! Handling Precautions

- Switching of MV1 and MV2, and outputs 1, 2 and 3 can be selected in setup data *C44*.
- Switching of control output and SP output can be selected in setup data *C18* and *C41*.
- SP output can be output to current output other than heat output and cool output.
- The “MV1/MV2 switching” function can be used for SP output even though SP output originally is not MV. So, SP output is shown to be connectable to MV1 and MV2 in the above figures for convenience only.

■ Control output CH1

When the DCP302 is selected for use as a controller, control output is operational. How outputs are processed varies according to the output type supported on the model.

● CH1 control output → Current output

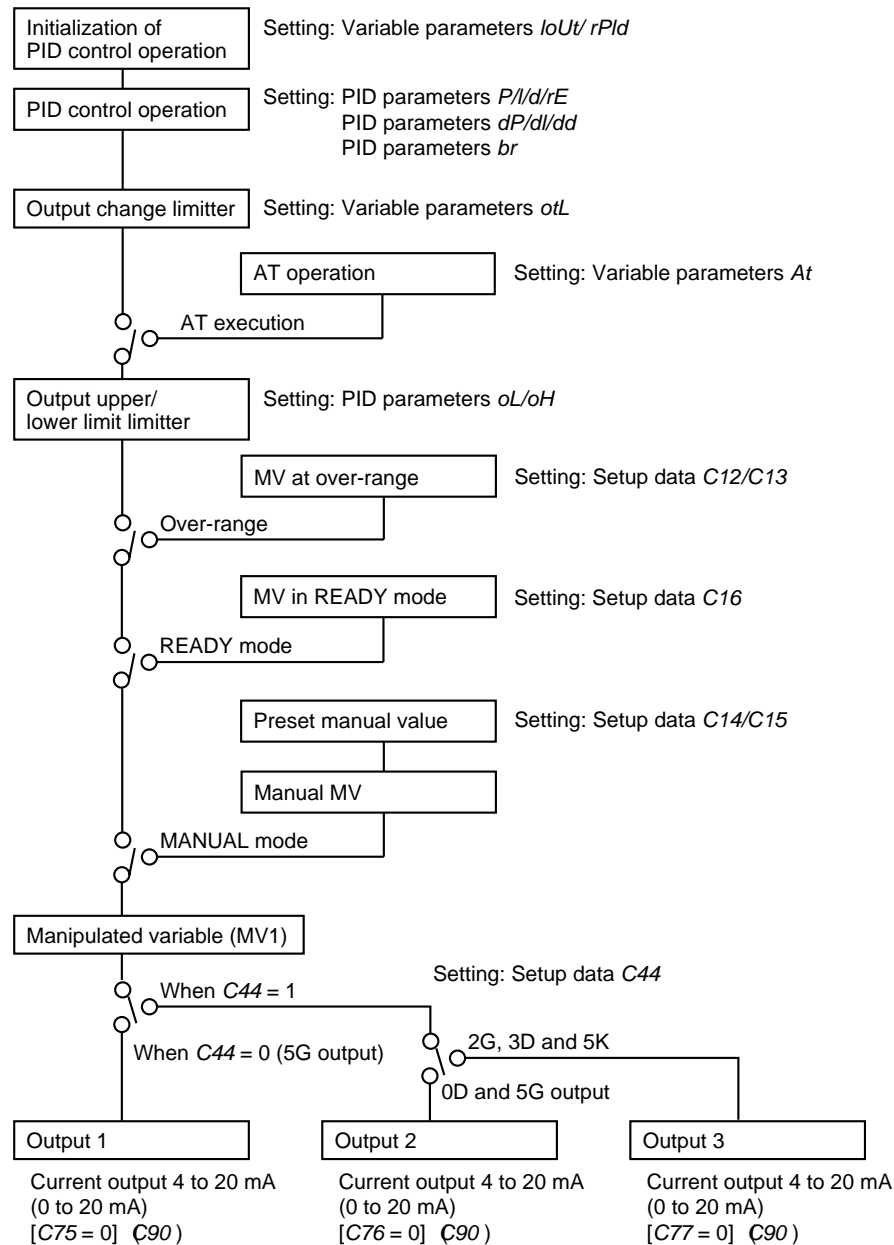

! Handling Precautions

- You can switch current output and voltage output in setup data $C75$, $C76$ and $C77$.
- You can switch 4 to 20 mA output and 0 to 20 mA output in setup data $C90$.

● CH2 control output → Current output

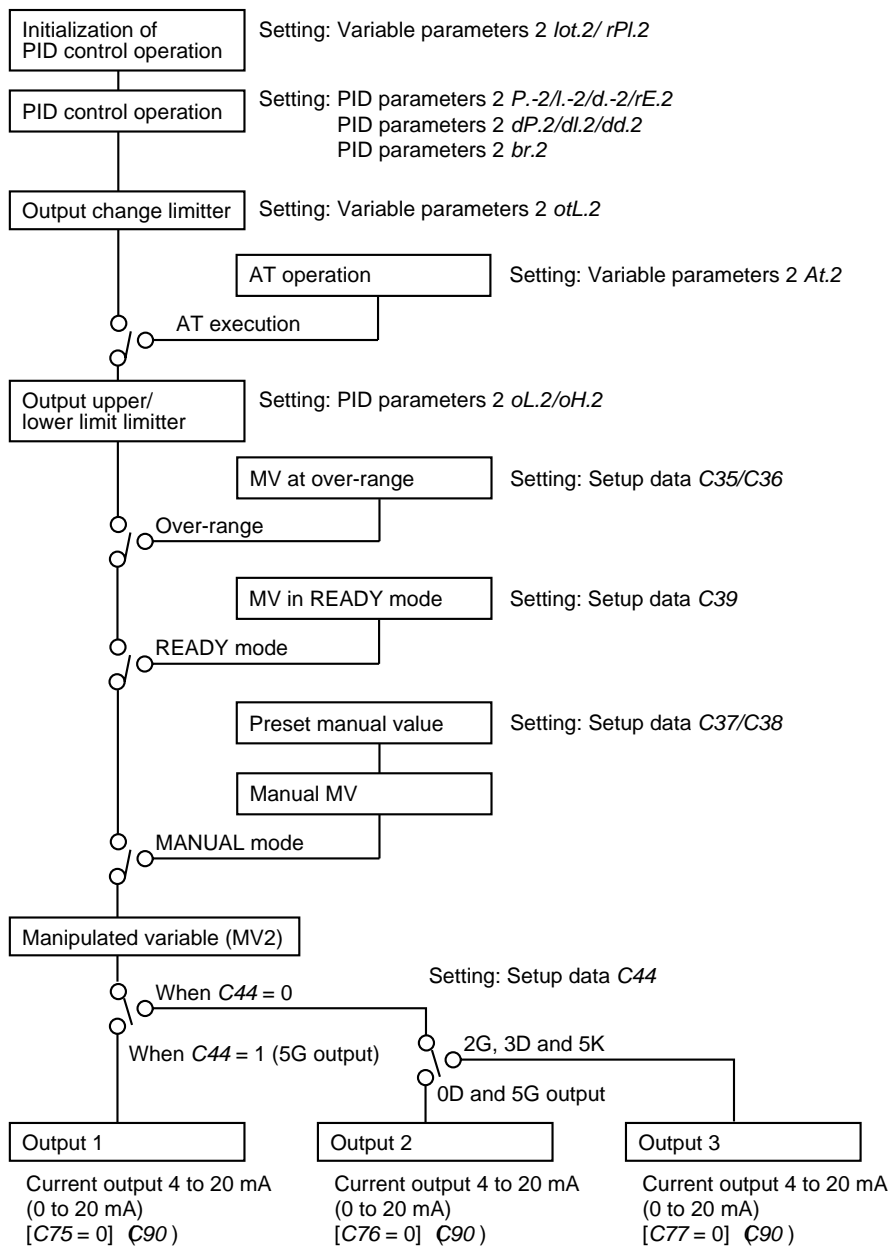

! Handling Precautions

- You can switch current output and voltage output in setup data C75, C76 and C77.
- You can switch 4 to 20 mA output and 0 to 20 mA output in setup data C90.

● CH1 control output → Relay output, voltage output

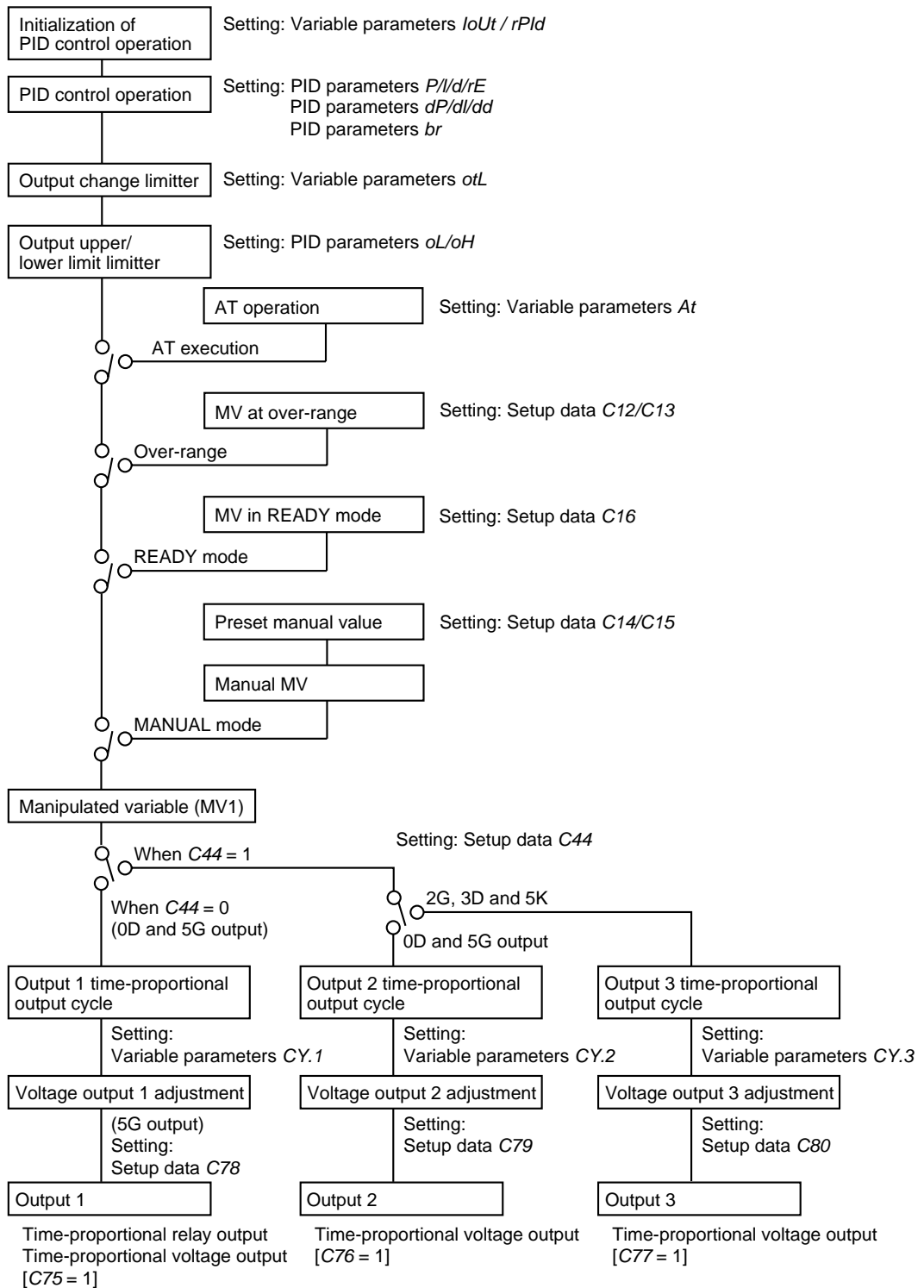

! Handling Precautions

- You can switch current output and voltage output in setup data C75, C76 and C77.

● CH2 control output → Relay output, voltage output

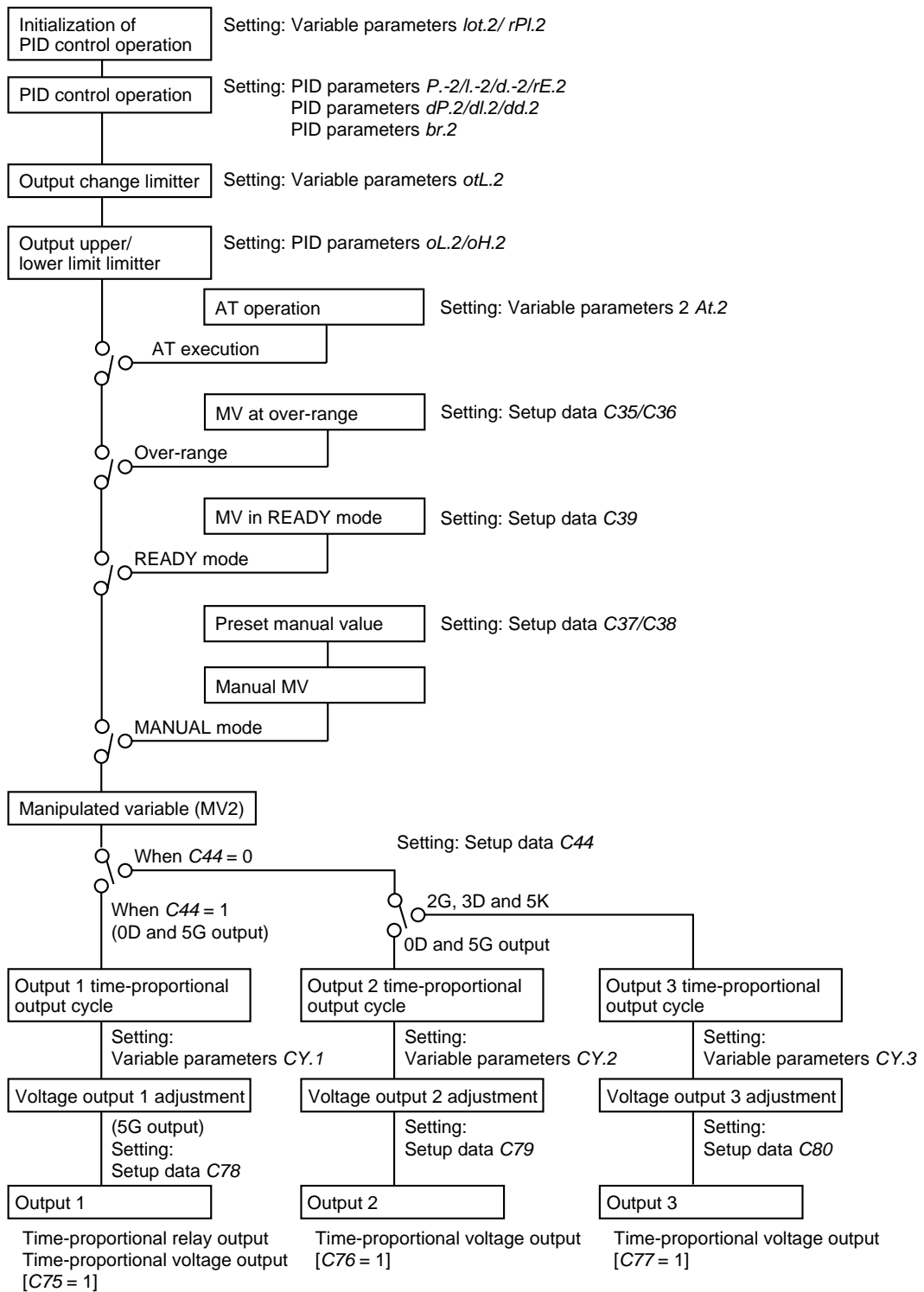

! Handling Precautions

- You can switch current output and voltage output in setup data C75, C76 and C77.

● CH1 control output → Position-proportional output

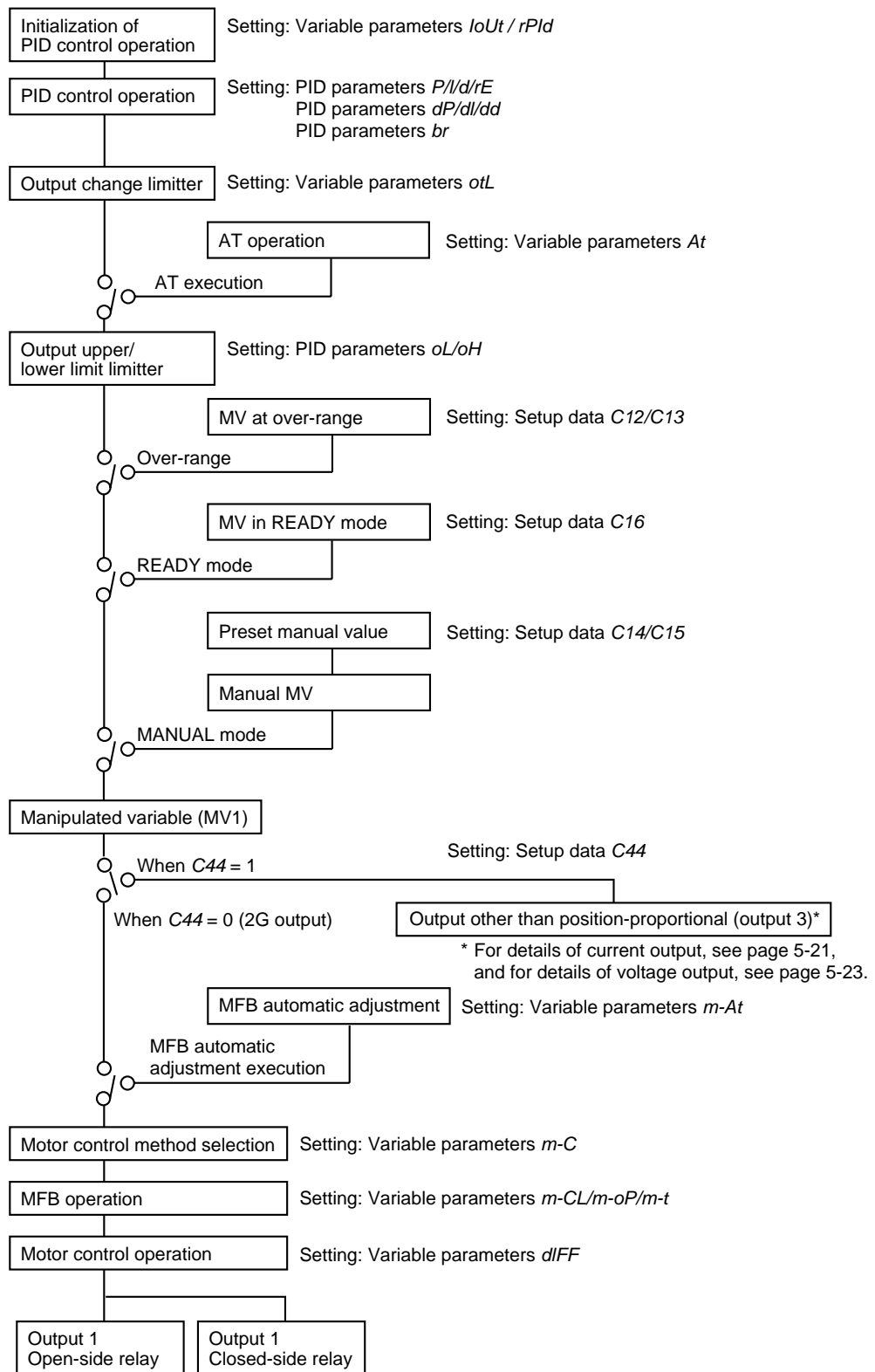

● CH2 control output → Position-proportional output

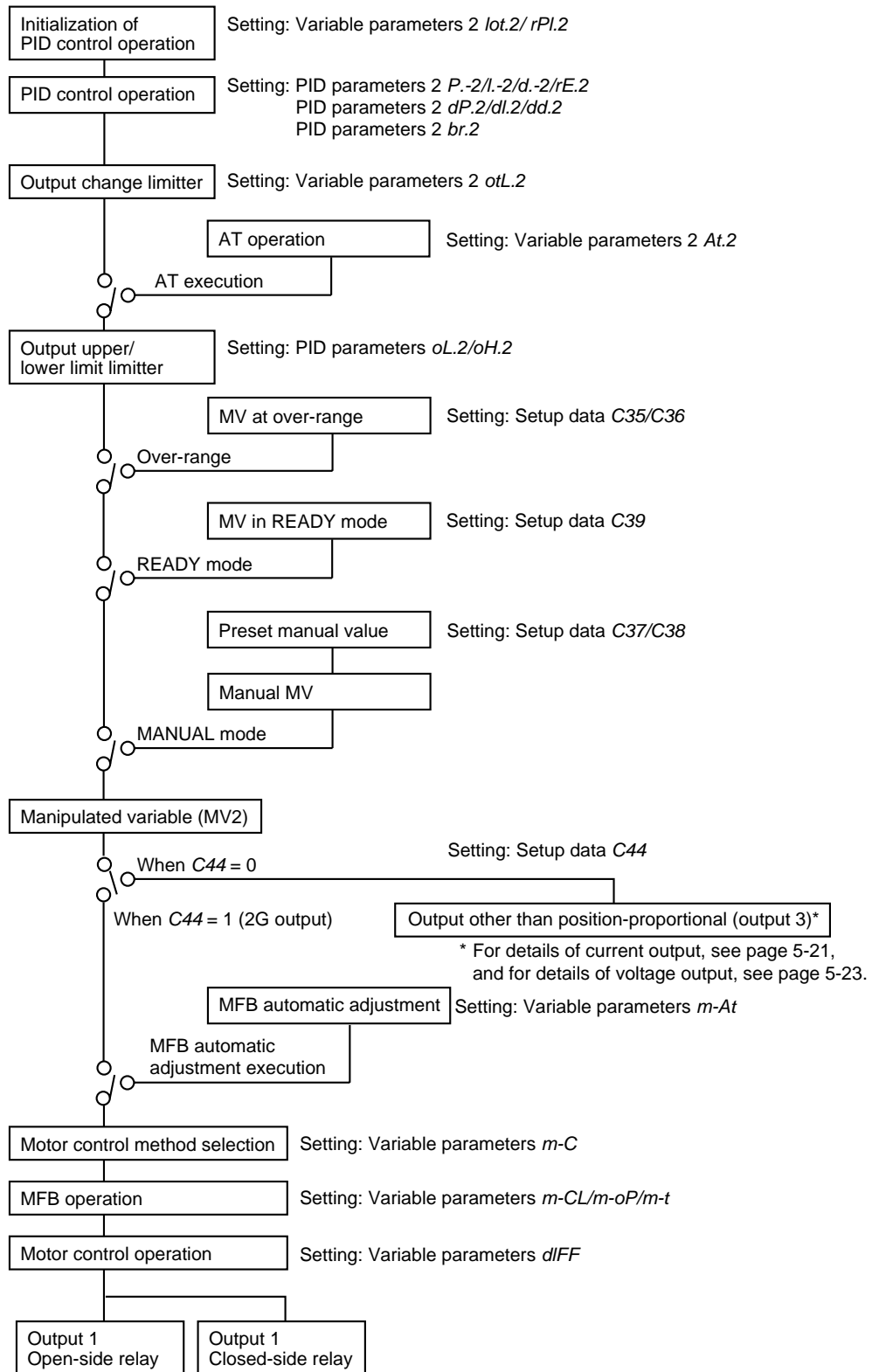

● CH1 control output → Heat/cool output

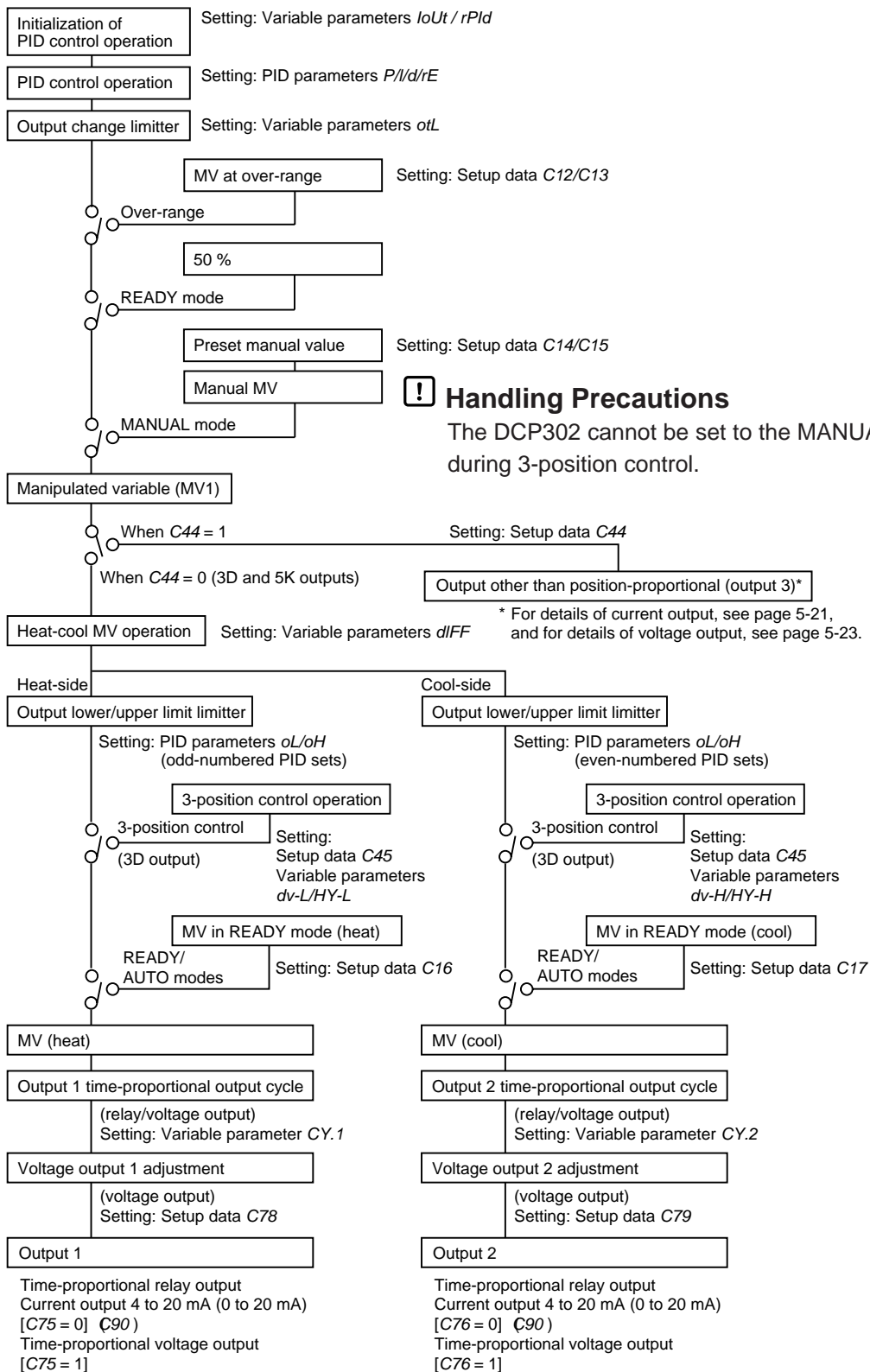

! Handling Precautions

The DCP302 cannot be set to the MANUAL mode during 3-position control.

* For details of current output, see page 5-21, and for details of voltage output, see page 5-23.

! Handling Precautions

- You can switch current output and voltage output in setup data C75, C76 and C77.
- You can switch 4 to 20 mA output and 0 to 20 mA output in setup data C90.

● CH2 control output → Heat/cool output

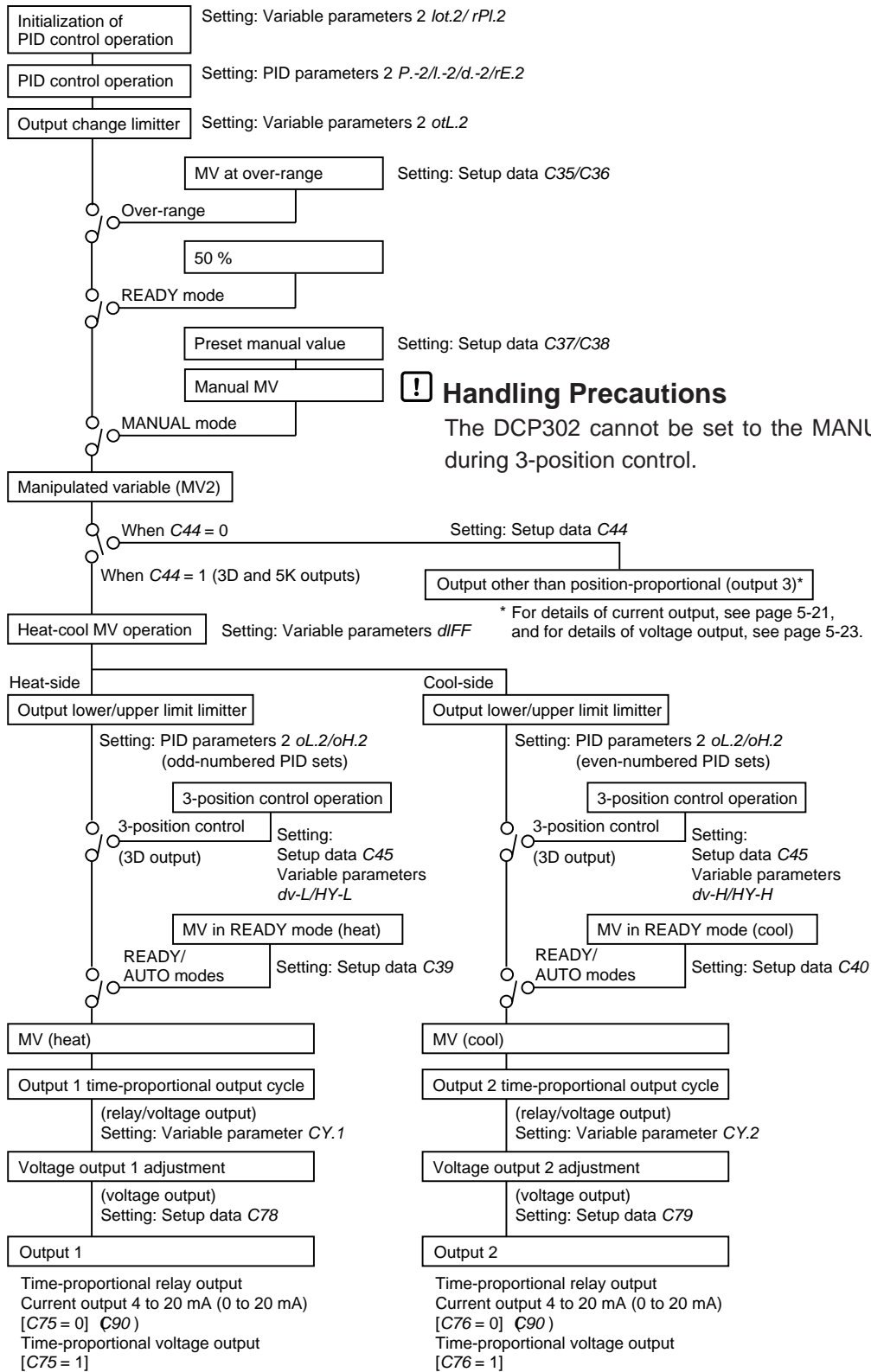

! Handling Precautions

The DCP302 cannot be set to the MANUAL mode during 3-position control.

* For details of current output, see page 5-21, and for details of voltage output, see page 5-23.

! Handling Precautions

- You can switch current output and voltage output in setup data *C75*, *C76* and *C77*.
- You can switch 4 to 20 mA output and 0 to 20 mA output in setup data *C90*.

■ SP output

When the DCP302 is selected for use as a programmer, control output is operational.

On current output models other than heat/cool, SP output is processed as follows.

● CH1 SP output

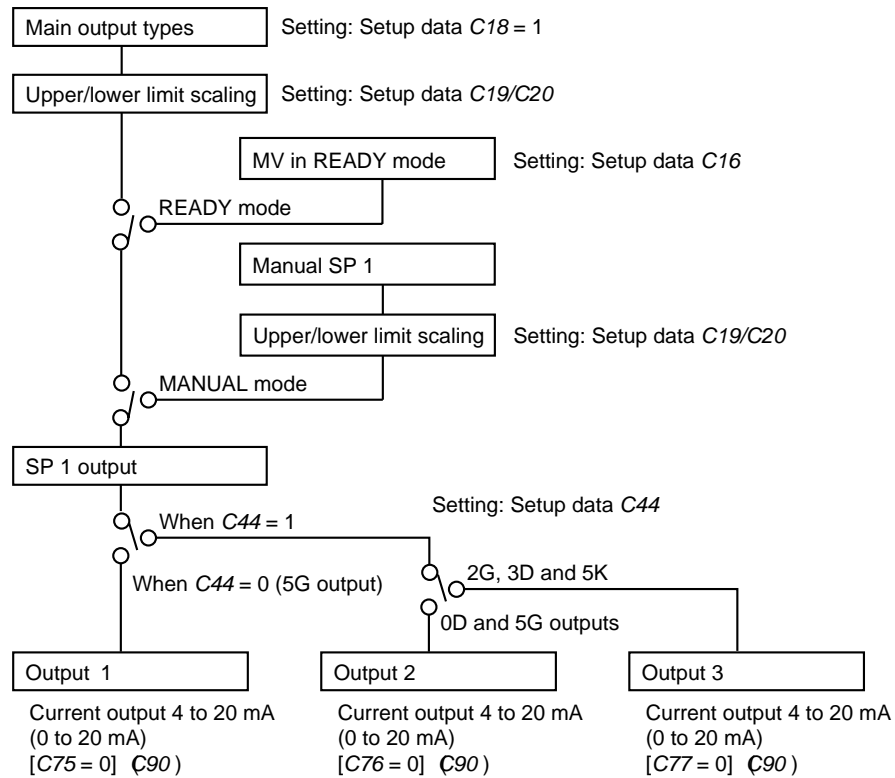

! Handling Precautions

- You can switch current output and voltage output in setup data C75, C76 and C77.
- You can switch 4 to 20 mA output and 0 to 20 mA output in setup data C90.

● CH2 SP output

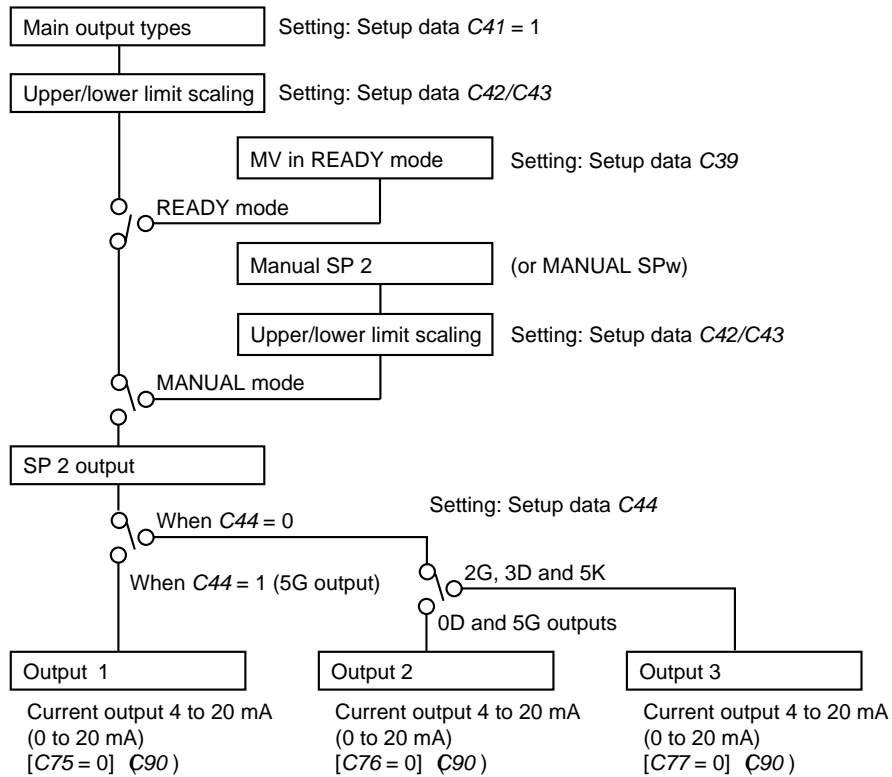

! Handling Precautions

- You can switch current output and voltage output in setup data C75, C76 and C77.
- You can switch 4 to 20 mA output and 0 to 20 mA output in setup data C90.

■ Auxiliary output

When auxiliary output is supported on 0D or 5G output models, auxiliary output 1 is processed as follows.

2G, 3D and 5K output models do not support auxiliary output.

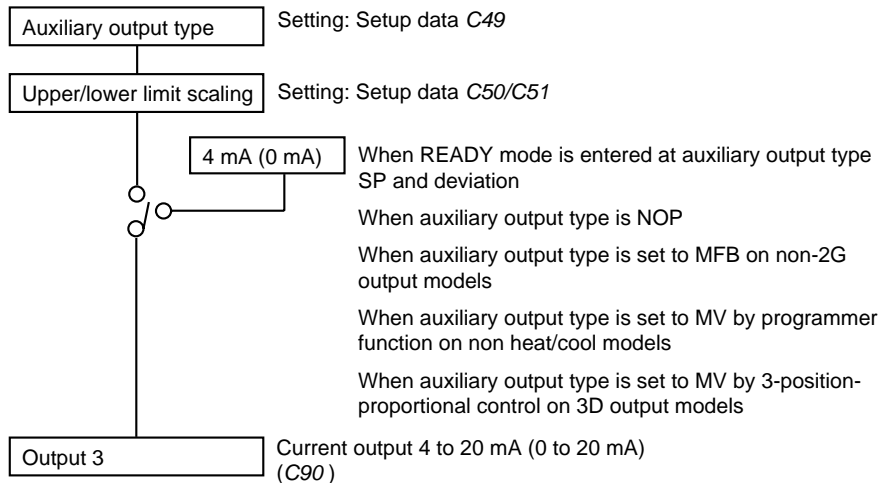

! Handling Precautions

- You can switch 4 to 20 mA output and 0 to 20 mA output in setup data C90.

Chapter 6. OPERATION

6 - 1 Turning the Power ON

The DCP302 is not equipped with a power switch or protective fuses. If necessary, prepare these externally. When a voltage of 90 to 264 Vac is applied across terminals ① and ② on the DCP302, the display appears for about ten seconds after which control and other operations are started. During initialization of the controller until start of operations, the LEDs on the profile display light successively at uneven intervals clockwise from top right.

The following diagram shows the flow of operations at startup.

● Startup flow

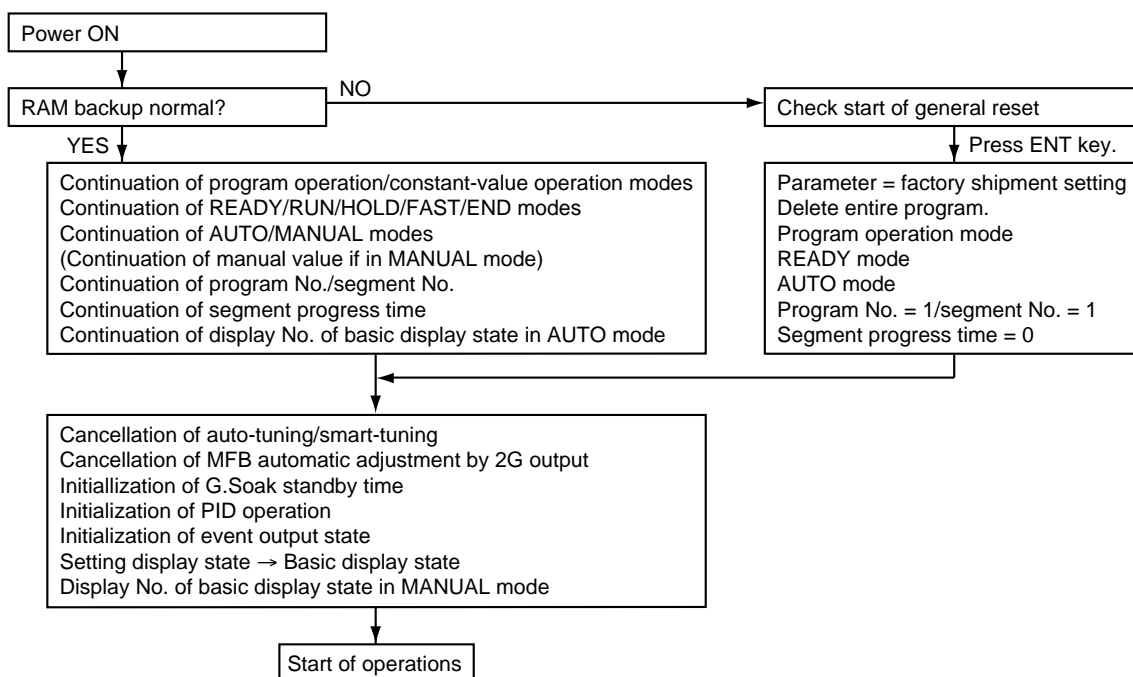

! Handling Precautions

With the following modes and items, the state that was active when the power was turned OFF continues when the power is turned back ON.

- READY, RUN, HOLD, FAST, END modes
- AUTO, MANUAL modes
- MANUAL values in the MANUAL mode
- Program No., segment No.
- Progress time in segment
- Display No. if in basic display state in the AUTO mode

6 - 2 Switching the Basic Display

The “basic display state” of the DCP302 collectively refers to the display state of the program No. display, segment No. display, upper display, lower display, basic indicator LED lamps and event LEDs.

Each press of the DISP key successively switches the basic display state, and each press of the DISP key with the FUNC key held down switches the channel displays between CH1 and CH2.

Operation of other displays and LEDs is carried out in the same way even when setting up parameters, for example. However, switching by the DISP key is not possible.

The profile display and AT LED indicates the status of the channel displayed in the basic display.

The following figure shows the conventions used for representing displays in this manual.

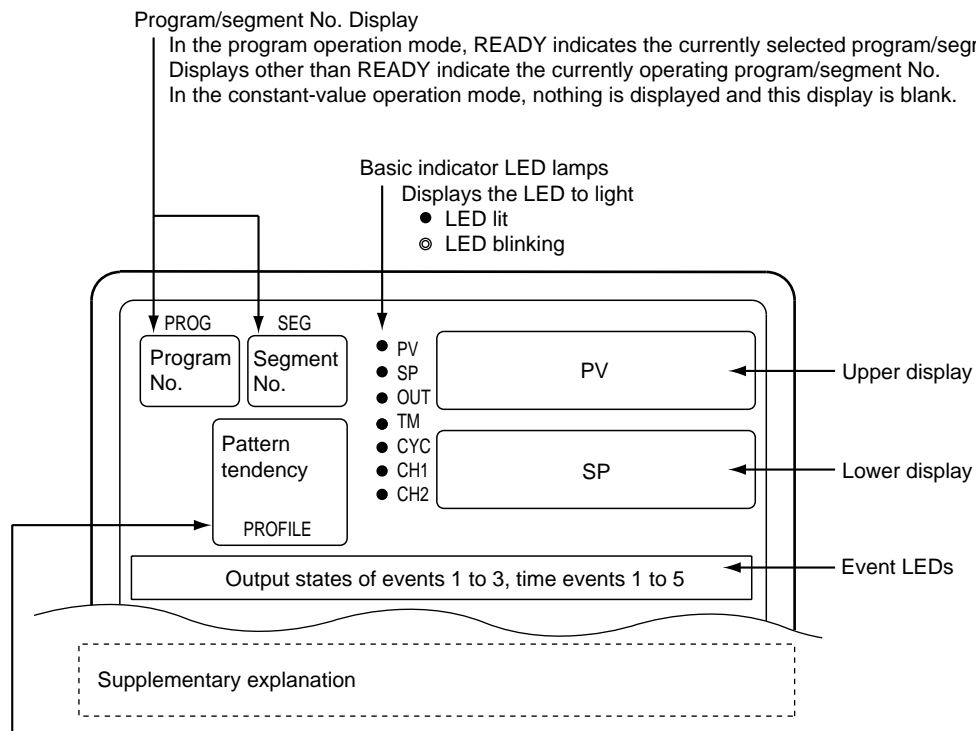

Profile Display

Displays the program status of the displayed channel.

In the program operation mode, the profile is displayed only when the program has been set up.

The profile is not displayed when the program is not set up.

When there is no subsequent segment even if the program is set up, the three LEDs on the right do not light.

In the constant-value operation mode, nothing is displayed and this display is blank.

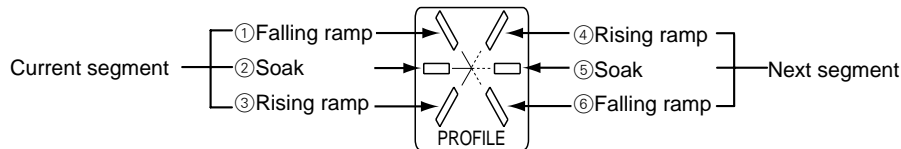

■ Display in program operation mode

● The DISP key functions

Output Format of Displayed Channel	Display
Relay, current, voltage	Display 1 → Display 2 → Display 3 → Display 6 → Display 7 → Display 8 → *Display 1 (repeated)
Position-proportional	Display 1 → Display 2 → Display 3 → Display 4 → Display 6 → Display 7 → Display 8 → *Display 1 (repeated)
Heat/cool	Display 1 → Display 2 → Display 3 → Display 5 → Display 6 → Display 7 → Display 8 → *Display 1 (repeated)

! Handling Precautions

When channel CH2 is displayed on temperature/humidity operation model, other displays are inserted at the position marked by an asterisk "*" depending on the setting of variable parameter 2 CH.2 as follows:

- When variable parameter 2 CH.2 is set to 1, display 9 is inserted.
- When variable parameter 2 CH.2 is set to 2, display 10 is inserted.

● FUNC key + DISP key functions

This key combination switches between CH1 display and CH2 display.

As the display number that is selected by the DISP key is independent to each channel, the display number on the CH1 and CH2 display is not necessarily the same number even if the displayed channel is switched by the FUNC key + DISP key combination.

● Display 1

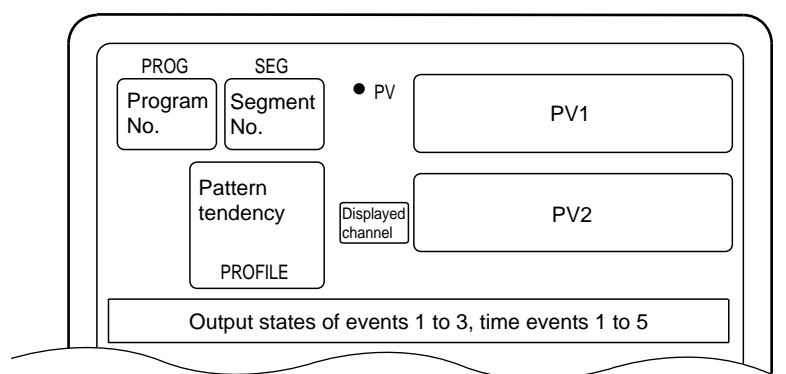

Display 1 indicates the PV of both channels. However, note that the lit LED of CH1 LED and CH2 LED indicates the displayed channel common to displays 1 to 11. A blinking LED indicates the channel displayed on display 1 only.

● Display 2

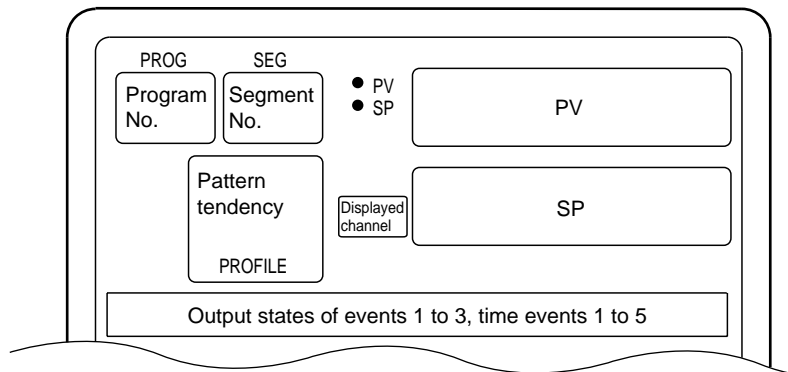

On the displayed channel, the digit to which an SP value can be entered blinks in the MANUAL mode when programmer functions are selected. However, note that in the MANUAL mode when SPw programmer functions are selected, none of the digits in SP blink on the CH2 display on temperature/humidity operation models.

● Display 3

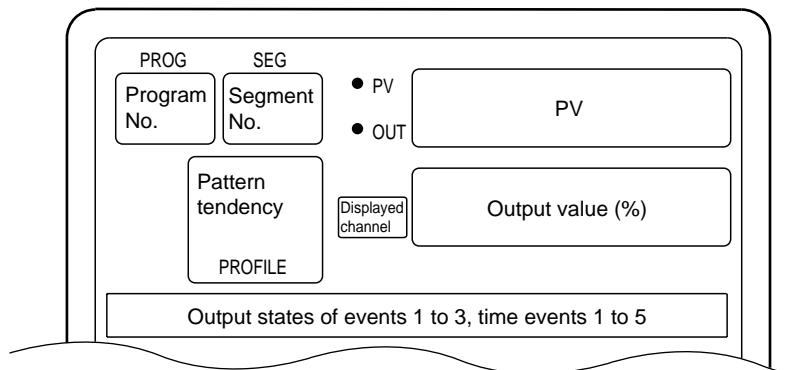

On the displayed channel, the digit to which an SP value can be entered blinks in the MANUAL mode when controller functions are selected.

● Display 4

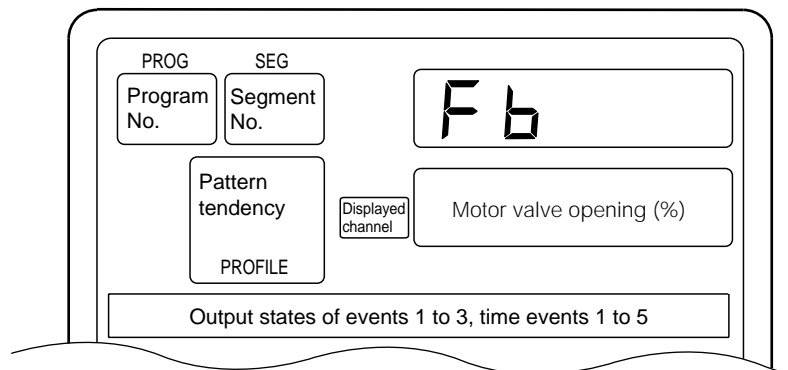

This display is exclusive to 2G output models (output model No. appended with 2G) when the displayed channel is position-proportional output.

● Display 5

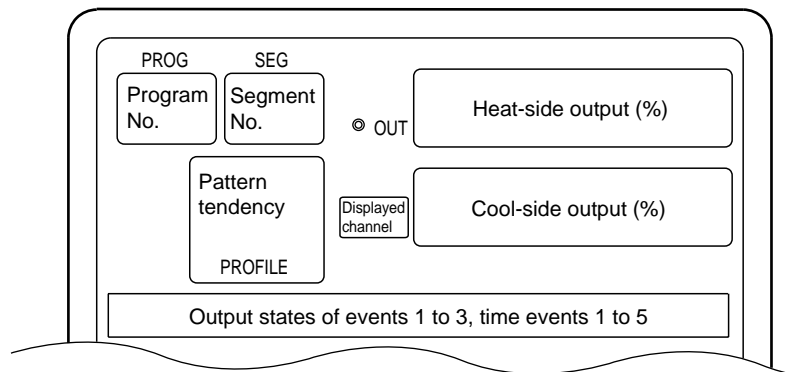

This display is exclusive to heat/cool output models (output model No. appended with 3D or 5K) when the displayed channel is heat/cool output.

● Display 6

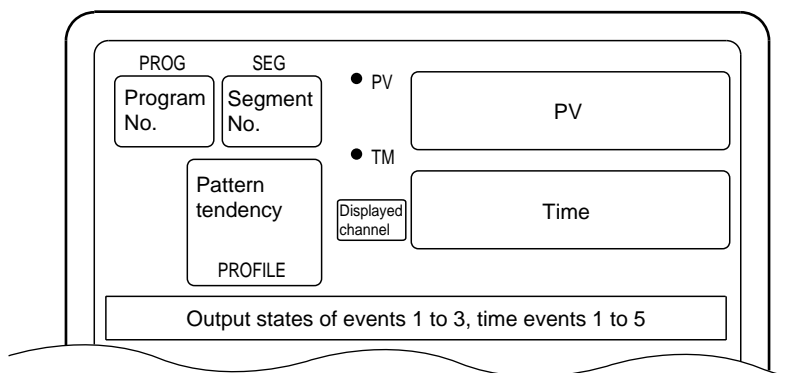

Either of “hours:minutes” or “minutes:seconds” is selected in setup data C64 as the time unit in the setup. Select either “remaining segment time” or “total operating time” in setup data C65 as the time display format.

● Display 7

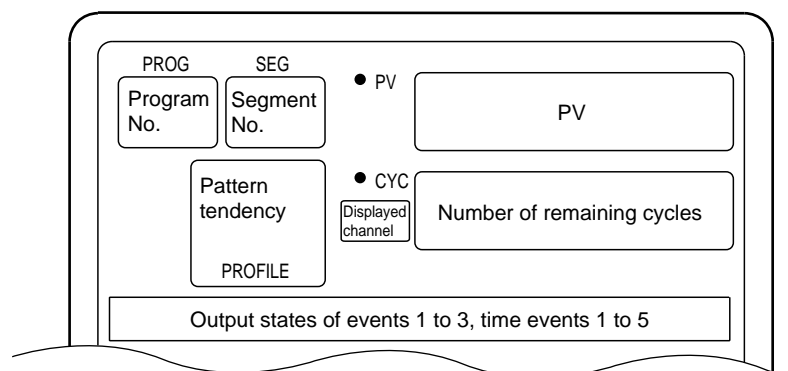

When the remaining number of cycles is “0”, subsequent cycle operation is not carried out.

● Display 8

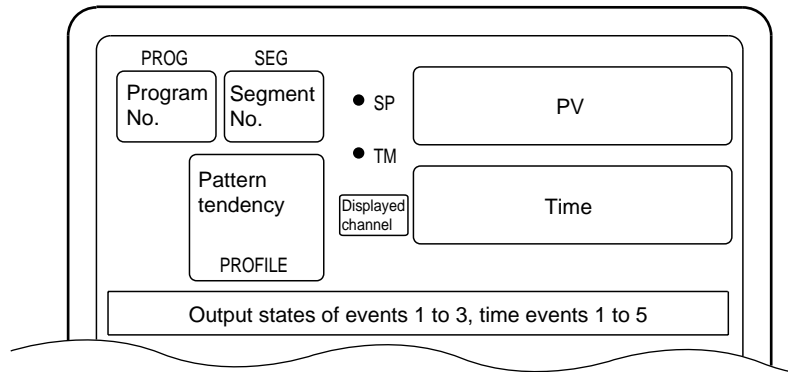

On the displayed channel, the digit to which an SP value can be entered blinks in the MANUAL mode when programmer functions are selected. However, note that in the MANUAL mode when SPw programmer functions are selected none of the digits in SP blink on the CH2 display on temperature/humidity operation models. Either of “hours:minutes” or “minutes:seconds” is selected in setup data C64 as the time unit in the setup. Select either “remaining segment time” or “total operating time” in setup data C65 as the time display format.

● Display 9

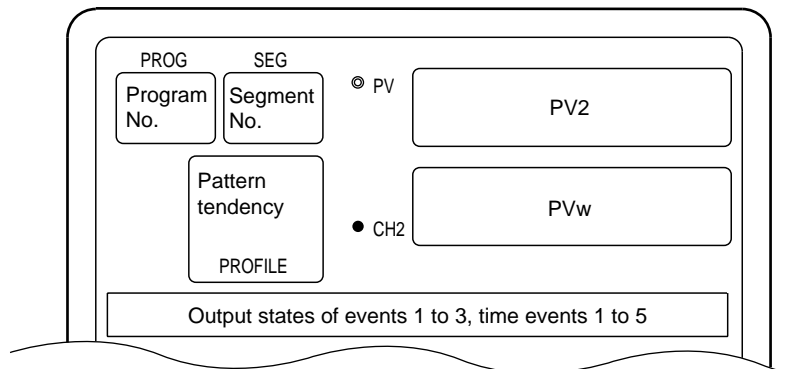

This display is exclusive to CH2 display on temperature/humidity operation models only when variable parameter 2 CH.2 is set to 1. PV2 indicates the relative humidity, while PVw indicates the wet-bulb temperature.

● Display 10

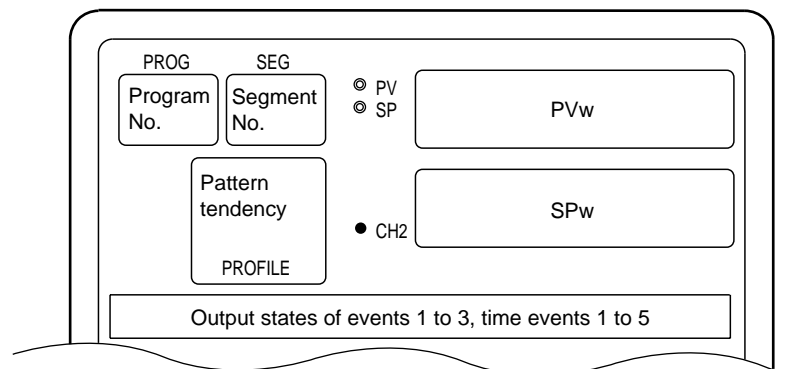

This display is exclusive to CH2 display on temperature/humidity operation models only when variable parameter 2 CH.2 is set to 2. PVw is the wet-bulb temperature, and SPw is the wet-bulb side SP. SPw is calculated from SP1 (dry-bulb side SP) and SP2 (relative humidity SP).

The digit to which an SP value can be entered blinks in the MANUAL mode when SPw programmer functions are selected.

■ Display in constant-value operation mode

● The DISP key functions

Output Format of Displayed Channel	Display
Relay, current, voltage	Display 1 → Display 2 → Display 3 → *Display 1 (repeated)
Position-proportional	Display 1 → Display 2 → Display 3 → Display 4 → *Display 1 (repeated)
Heat-cool	Display 1 → Display 2 → Display 3 → Display 5 → *Display 1 (repeated)

! Handling Precautions

When channel CH2 is displayed on temperature/humidity operation model, other displays are inserted at the position marked by an asterisk “*” depending on the setting of variable parameter 2 CH.2 as follows:

- When variable parameter 2 CH.2 is set to 1, display 6 is inserted.
- When variable parameter 2 CH.2 is set to 2, display 7 is inserted.

● FUNC key + DISP key functions

This key combination switches between CH1 display and CH2 display.

As the display number that is selected by the DISP key is independent to each channel, the display number on the CH1 and CH2 display is not necessarily the same number even if the displayed channel is switched by the FUNC key + DISP key combination.

● Display 1

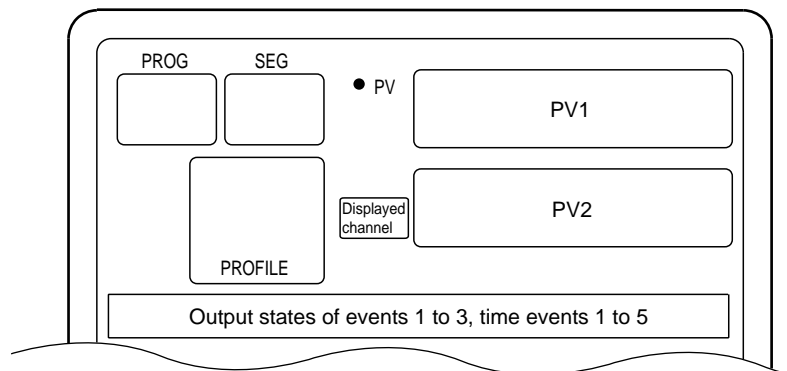

Display 1 indicates the PV of both channels. However, note that the lit LED of CH1 LED and CH2 LED indicates the displayed channel common to displays 1 to 7. A blinking LED indicates the channel displayed on display 1 only.

● Display 2

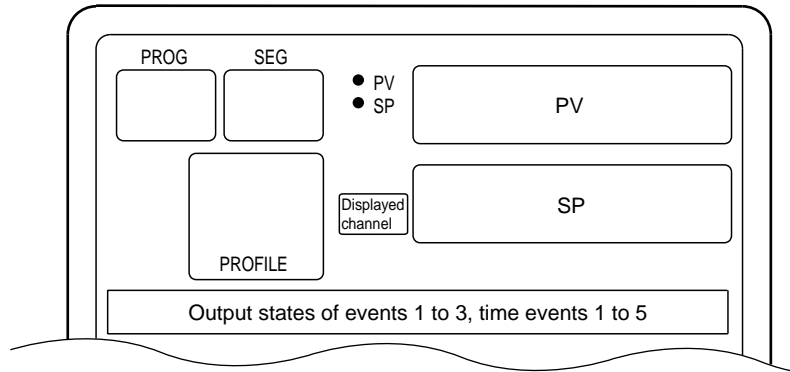

On the displayed channel, the digit to which an SP value can be entered blinks in the MANUAL mode when programmer functions are selected. However, note that in the MANUAL mode when SPw programmer functions are selected, none of the digits in SP blink on the CH2 display on temperature/humidity operation models.

● Display 3

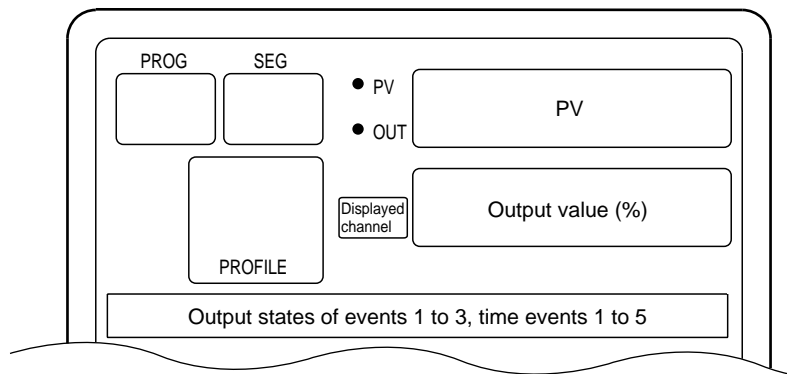

On the displayed channel, the digit to which an SP value can be entered blinks in the MANUAL mode when controller functions are selected.

● Display 4

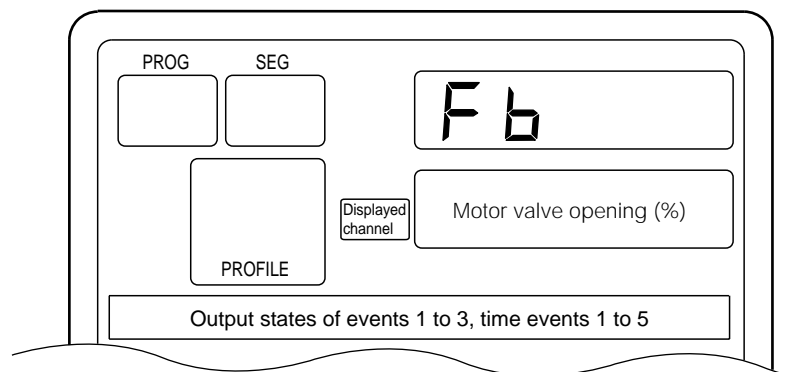

This display is exclusive to 2G output models (output model No. appended with 2G) when the displayed channel is position-proportional output.

● Display 5

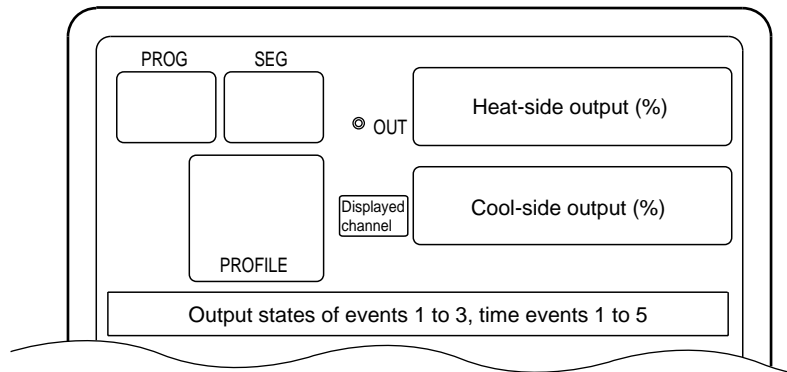

This display is exclusive to heat/cool output models (output model No. appended with 3D or 5K) when the displayed channel is heat/cool output.

● Display 6

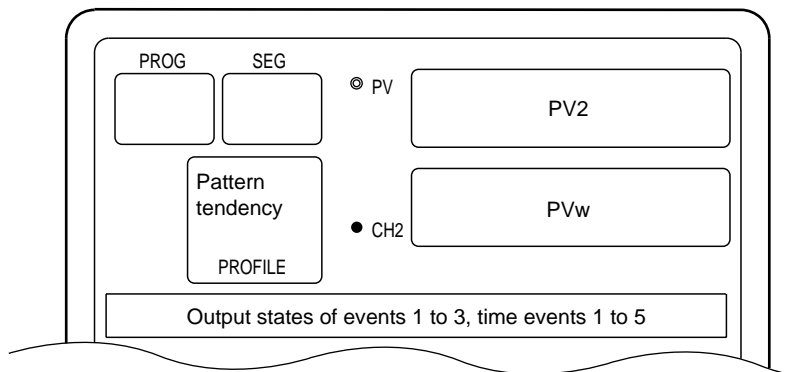

This display is exclusive to CH2 display on temperature/humidity operation models only when variable parameter 2 *CH.2* is set to 1. PV2 indicates the relative humidity, while PVw indicates the wet-bulb temperature.

● Display 7

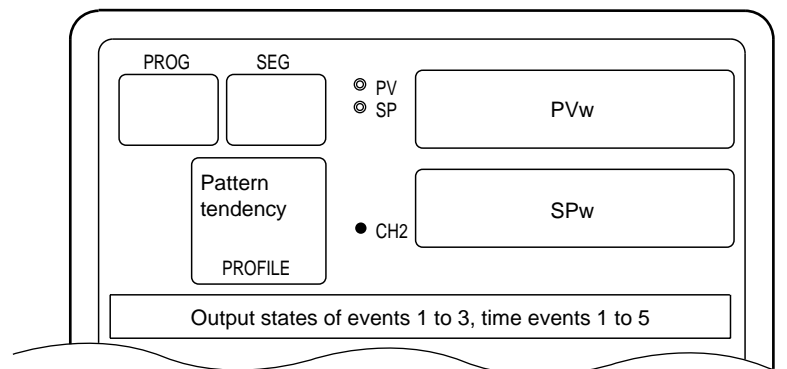

This display is exclusive to CH2 display on temperature/humidity operation models only when variable parameter 2 *CH.2* is set to 2. PVw is the wet-bulb temperature, and SPw is the wet-bulb side SP. SPw is calculated from SP1 (dry-bulb side SP) and SP2 (relative humidity SP).

The digit to which an SP value can be entered blinks in the MANUAL mode when SPw programmer functions are selected.

6 - 3 Program Selection

The program No. can be selected using the keys on the console within the range 1 to 19.

■ How to select the program No.

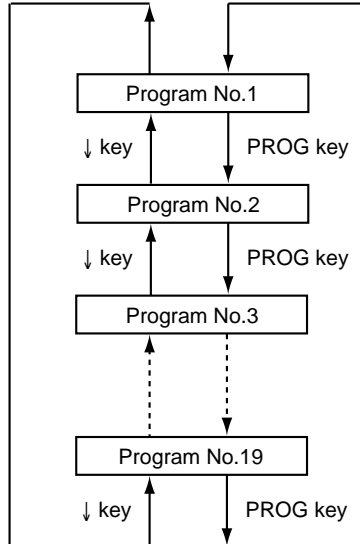

When the DCP302 is in the basic display state in the program operation READY mode:

- Each press of the PROG key increments the program No. The display reverts to 1 after 19.
- Each press of ↓ decrements the program No. The display reverts to 19 after 1.

! Handling Precautions

- Program Nos. can be selected whether they are already set or not.
- A program No. currently selected by external switch input cannot be selected.
- The program No. cannot be selected during constant-value operation.
- Pressing ↓ does not change the program No. when values currently being entered are displayed in the MANUAL mode.

6 - 4 External Switch (RSW) Operations

■ External switch (RSW) inputs

In all, the DCP302 is provided with 12 external switch inputs. Each of these inputs are differentiated by RSW1, RSW2 and so forth up to RSW12. On models whose option 2 model No. is “0”, only inputs RSW1 to RSW4 are mounted.

(RSW: external switch input)

● External switch input types

The functions of RSW1 to 4, and RSW8 to 12 are fixed.

The functions of RSW5 to 7 are selected by setup data *C71* to *C74*.

External Switch No.	Function	Detection Method
RSW1	RUN	Rising edge
RSW2	HOLD	Rising edge
RSW3	RESET	Rising edge
RSW4	ADV	Rising edge
RSW5	Selected by setup from the following functions	
RSW6	FAST	Rising edge
RSW7	PV start (using PV1)	Rising edge
	PV start (using PV2)	Rising edge
	AUTO/MANUAL (CH1)	Rising/falling edge
	AUTO/MANUAL (CH2)	Rising/falling edge
	AT start/stop (CH1)	Rising/falling edge
	AT start/stop (CH2)	Rising/falling edge
	G.Soak cancel by OR conditions	Status
	G.Soak cancel by AND conditions	Status
	Direct/reverse action switching (CH1)	Status
	Direct/reverse action switching (CH2)	Status
RSW8	Program No. selection Weighting 1	Status
RSW9	Program No. selection Weighting 2	Status
RSW10	Program No. selection Weighting 4	Status
RSW11	Program No. selection Weighting 8	Status
RSW12	Program No. selection Weighting 10	Status

Note

- With “G.Soak cancel by OR conditions,” G.Soak standby is canceled when the external switch turns ON, or when the PV is within the G.Soak width setting.
- With “G.Soak cancel by AND conditions,” G.Soak standby is canceled when the external switch turns ON and the PV is within the G.Soak width setting.
- With “direct/reverse action switching (CH1),” direct/reverse action follows the setting of setup data *C01* when the external switch turns OFF. When the external switch turns ON, action is opposite to the setting of setup data *C01*.
- With “direct/reverse action switching (CH2),” direct/reverse action follows the setting of setup data *C21* when the external switch turns OFF. When the external switch turns ON, action is opposite to the setting of setup data *C21*.

■ Program selection

The program can be selected by external switch input in the program operation READY mode. The table below shows program selection by external switch inputs. Two external switch states are provided for selection of programs 10 to 15. When program selection by external switch inputs is set to “0”, the program can be selected by the console keys and by communication with a personal computer.

External Switch No.	Weighting	State									
RSW8	1	OFF	ON	OFF	ON	OFF	ON	OFF	ON	OFF	ON
RSW9	2	OFF	OFF	ON	ON	OFF	OFF	ON	ON	OFF	OFF
RSW10	4	OFF	OFF	OFF	OFF	ON	ON	ON	ON	OFF	OFF
RSW11	8	OFF	OFF	OFF	OFF	OFF	OFF	OFF	OFF	ON	ON
RSW12	10	OFF	OFF	OFF	OFF	OFF	OFF	OFF	OFF	OFF	OFF
Program No. Selection		0	1	2	3	4	5	6	7	8	9

External Switch No.	Weighting	State											
RSW8	1	OFF	OFF	ON	ON	OFF	OFF	ON	ON	OFF	OFF	ON	ON
RSW9	2	OFF	ON	OFF	ON	ON	OFF	ON	OFF	OFF	ON	OFF	ON
RSW10	4	OFF	OFF	OFF	OFF	OFF	ON	OFF	ON	ON	ON	ON	ON
RSW11	8	OFF	ON	OFF	ON	OFF	ON	OFF	ON	OFF	ON	OFF	ON
RSW12	10	ON	OFF	ON	OFF	ON	OFF	ON	OFF	ON	OFF	ON	OFF
Program No. Selection		10		11		12		13		14		15	

External Switch No.	Weighting	State									
RSW8	1	OFF	ON	OFF	ON	OFF	ON	OFF	ON	OFF	ON
RSW9	2	ON	ON	OFF	OFF	ON	ON	OFF	OFF	ON	ON
RSW10	4	ON	ON	OFF	OFF	OFF	OFF	ON	ON	ON	ON
RSW11	8	OFF	OFF	ON	ON	ON	ON	ON	ON	ON	ON
RSW12	10	ON	ON	ON	ON	ON	ON	ON	ON	ON	ON
Program No. Selection		16	17	18	19	0					

■ Read timing

● Timing of inputs RSW1 to 7

Inputs RSW1 to RSW7 are read according to the following timing.

- ① When input state changes from OFF to ON, the time from the change up to reading is 0.2 seconds max.
- ② When input state changes from ON to OFF, the time from the change up to reading is 0.2 seconds max.

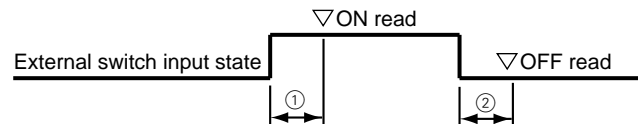

● Timing of inputs RSW8 to 12, RUN and PV start

The time from the change in input state up to reading when selecting program Nos. by RSW8 to RSW12 is 0.4 seconds max.

Accordingly, due to the relationship with RUN operation, be sure to observe timings ① to ④ in the following diagram.

PV start operation also must conform to RUN operation.

- ① The time from fixing of the selected No. up to the rising edge of the RUN signal is 0.4 seconds min.
- ② The time from the rising edge of the RUN signal up to holding of the program No. is 0.2 seconds min.
- ③ The time from holding of RUN signal OFF up to the rising edge of the RUN signal is 0.2 seconds min.
- ④ The time from the rising edge of the RUN signal up to holding of RUN signal ON is 0.2 seconds min.
- ⑤ The time from fixing of the selected No. up to changing of the program No. is 0.4 seconds max.
- ⑥ The time from the rising edge of the RUN signal up to start of RUN is 0.4 seconds max.

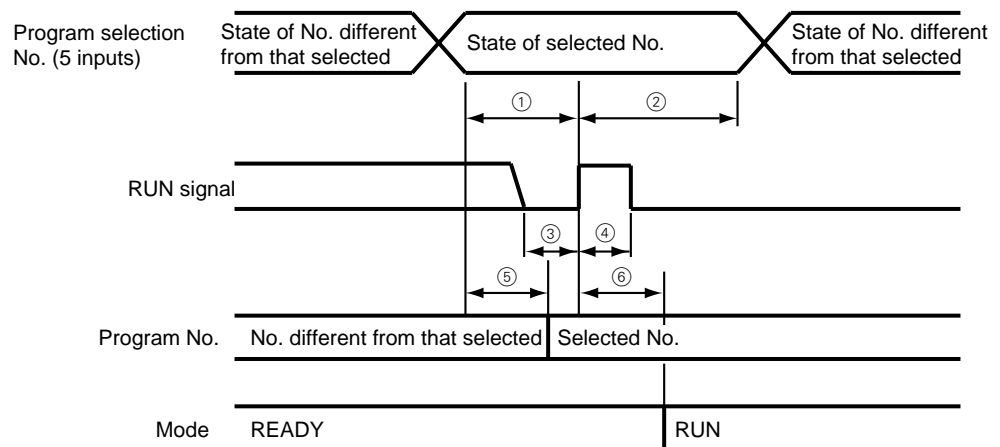

❗ Handling Precautions

When operating the DCP302 by external switch inputs, operation can be carried out more reliably if a margin is added to the minimum time for the above read timings.

6 - 5 Manual Operation and Auto-tuning

■ Manual operation

In the MANUAL mode, controller outputs can be manipulated by ↑ or ↓ on the console.

● Controller functions

When outputs are displayed in the basic display state, only one digit in the output value blinks. If the output value is incremented or decremented by ↑ or ↓, actual output also increments or decrements. Output values differ from values being entered to setting items in that the ENT key need not be pressed.

The blinking digit can be moved by pressing ← or →.

On 2G output models, when only estimated position-proportional control is selected by variable parameter *m-C* setting 2, “----” not the value is displayed as the output display in the MANUAL mode.

Pressing ↑ displays “*oPEn*”, and the open-side relay turns ON.

Pressing ↓ displays “*CLoS*”, and the closed-side relay turns ON.

Bump-less and preset output changes when moving from the AUTO to the MANUAL mode can be selected by setup data *C14* (for MV1) or *C37* (for MV2) setting. When moving from the MANUAL to the AUTO mode, the change in output is bumpless.

(However, note that a sudden change in output occurs when the total time for the PID parameter of the PID set in use is set to “0”.)

● Programmer functions

On the current output channel, when programmer functions are in operation with setup data *C18* (for CH1) or *C41* (for CH2) set to 1, SP can be manually manipulated. When SP is displayed in the basic display state, only one digit in the SP value being entered blinks. When the SP value is incremented or decremented by ↑ or ↓, the actual SP output also increments or decrements. SP values differ from values being entered to setting items in that the ENT key need not be pressed.

The blinking digit can be moved by pressing ← or →.

Output changes when moving from the AUTO to the MANUAL mode are bumpless regardless of setup data *C14* (for CH1) or *C37* (for CH2) setting. When moving from the MANUAL to the AUTO mode, the SP becomes the program pattern SP, which results in a sudden change in output.

■ Auto-tuning (AT)

When operating in the AUTO mode in either of the RUN, HOLD, FAST or END modes, setting values can be automatically written to the PID set in use by auto-tuning (AT). The following can be selected by variable parameter *At* (for CH1) or *At.2* (for CH2) setting.

0: AT is disabled.

1: General AT is executed.

2: Overshoot-inhibited AT is executed.

3: AT by neutral net is executed.

- Auto-tuning does not function when programmer functions are selected on heat/cool output channel models and current output channel models.

- During execution of auto-tuning, progress of program operation time stops. Accordingly, the DCP302 is in a similar state to the HOLD mode even in the RUN or FAST modes.
- Auto-tuning in all instances involves calculating the downtime and critical sensitivity of the control system according to two limit cycles and PID values according to suitable characteristic equations for each, and automatically writing these PID values.
- During execution of auto-tuning, PV fluctuates according to fluctuations in MV. Before executing auto-tuning, make sure that fluctuations in PV will not cause controller trouble.
- Normally, suitable values are written by setting variable parameter *At* setting to 1 or 3. However, when executing auto-tuning on a control system that easily overshoots, either set to 2, or also use smart-tuning for carrying out overshoot inhibit control. Setting to 3 executes AT by neural net so that suitable values are calculated for wider range applications.
- The point at which output at auto-tuning is inverted (lower limit to upper limit, and vice versa) is determined as follows from SP and PV at start of auto-tuning.

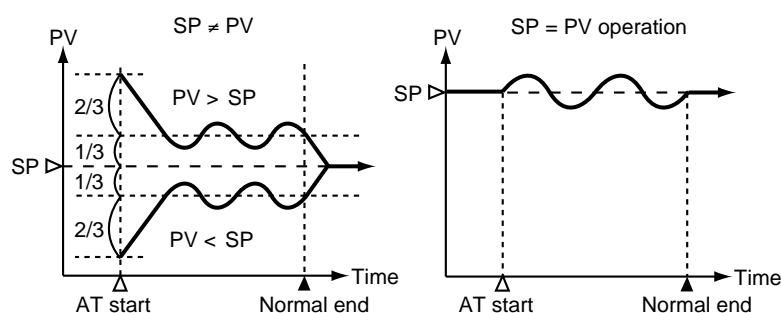

- Auto-tuning can be started by the AT key, external switch inputs and communications. The AT key functions on the currently displayed channel. During auto-tuning, the AT LED on the currently displayed channel blinks.
- If one or more of the following conditions occurs during auto-tuning, auto-tuning is canceled without PID constants being written, and the AT LED goes out.
 - Cancellation by the AT key (when the displayed channel indicates auto-tuning in progress)
 - Cancellation by external switch input
 - Cancellation by communications
 - Change in mode (move to MANUAL mode or READY mode)
 - Execution of automatic motor valve opening adjustment on 2G output models
 - When variable parameter *At* (for CH1) setting is changed to “0”
 - When variable parameter 2 *At.2* (for CH2) setting is changed to “0”
 - When PV becomes out-of-range

! Handling Precautions

- Auto-tuning will not function properly unless the control target is connected.
- The time from start to end of auto-tuning varies according to the control target.

- When auto-tuning is executed, control is stopped, and ON/OFF output switching (if the output type is relay output or voltage output) or output switching between the manipulated variable upper and lower limits of the currently selected PID set (if the output type is current output or position-proportional output) is repeated several times. If this causes controller trouble, manually set the PID value.
- Sometimes a suitable PID value cannot be obtained depending on the control target. If this happens, manually set the PID value.
- Though auto-tuning can be executed simultaneously on both the CH1 and CH2 channels, suitable PID values cannot be obtained if PVs in each channel interfere with each. If this happens, execute auto-tuning on each channel individually.

Chapter 7. PARAMETER SETUP

7 - 1 Parameter Setup

You can enter the parameter setup state when the DCP302 is in the basic display state.

If the DCP302 is not in the basic display state, press the DISP key to set the DCP302 to the basic display state.

■ Selecting the setting group in the parameter setup

Parameter setup is divided into two stages: setting group (major item) and individual item (minor item).

If you press the FUNC key + the PARA key in the basic display state, the display changes to selection of setting group (major item), the setting group is displayed on the upper display, and the lower display goes out.

If you press the PARA key, ↑ or ↓, the setting group display changes in order.

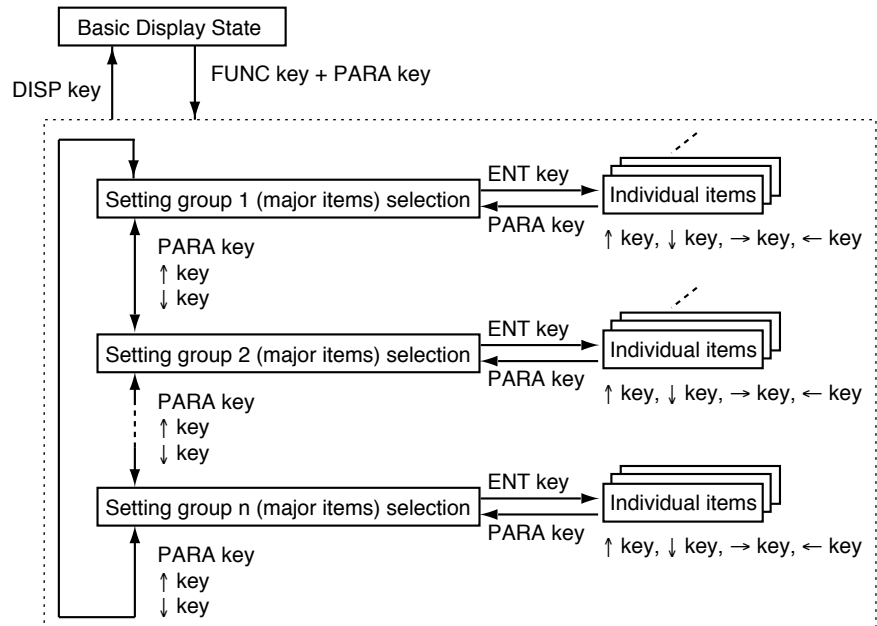

If you press the ENT key when the setting group to be selected is displayed, the display moves to the individual (minor) item level.

The following table shows the setting groups.

Name	Upper Display	Remarks
Variable parameters	<i>PARA</i>	
Variable parameters 2	<i>PAR2</i>	This parameter is not displayed when variable parameter <i>LoC</i> is 2 or 4.
Event configuration data	<i>Eu</i>	This parameter is not displayed when variable parameter <i>LoC</i> is 2 or 4.
PID parameters 1	<i>PI1</i>	This parameter is not displayed when variable parameter <i>LoC</i> is 2 or 4. This parameter is not displayed when constant-value operation data <i>modE</i> is 1. This parameter is not displayed when the output type on CH1 is current output and setup data C18 is 1. This parameter is not displayed when the output type on CH1 is heat/cool3D output and setup data C45 is 1.
PID parameters 2	<i>PI2</i>	This parameter is not displayed when variable parameter <i>LoC</i> is 2 or 4. This parameter is not displayed when constant-value operation data <i>modE</i> is 1. This parameter is not displayed when the output type on CH2 is current output and setup data C41 is 1. This parameter is not displayed when the output type on CH1 is heat/cool3D output and setup data C45 is 1.
Setup data	<i>SEt</i>	This parameter is not displayed when variable parameter <i>LoC</i> is 1, 2 or 4.
Table data	<i>tbL</i>	This parameter is not displayed when variable parameter <i>LoC</i> is 2 or 4.
Constant-value operation data	<i>CnSt</i>	This parameter is not displayed when variable parameter <i>LoC</i> is 2 or 4.

■ Moving individual items in the parameter setup

With individual (minor) items, item codes are displayed in the upper display and setting values are displayed in the lower display.

The program No. display goes out, and the item No. is displayed in the segment No. display. However, note that the segment No. display also goes out in the case of setup data.

Individual items are arranged in the form of a matrix as shown on the following page, and can be displayed in order by pressing ↑, ↓, ← or →. The size of individual item matrices varies according to the setting group.

■ Changing individual items and how to return from the setup state

If you press the ENT key when an individual item is displayed, the setting value blinks. This state is referred to as the “setting value entry state” In this state, pressing ↑ or ↓ can increment or decrement the setting value that is blinking. Also, pressing ← or → moves the position of the digit that is blinking.

If you press the ENT key when the setting value that is blinking is at the desired value, blinking stops, the display returns to its normal lit state, and the new setting value is stored to internal memory.

To cancel changing of setting values, press the PARA key or the DISP key. When the PARA key is pressed, the value stops blinking and the display returns to its normal lit state.

If you press the DISP key, the display returns to the basic display state. If “- - -” is displayed at the lower display when an individual item is displayed, or the DCP302 does not enter the setting value entry state by pressing the ENT key, that item cannot be set nor changed.

- Example of individual item matrix (setup data)

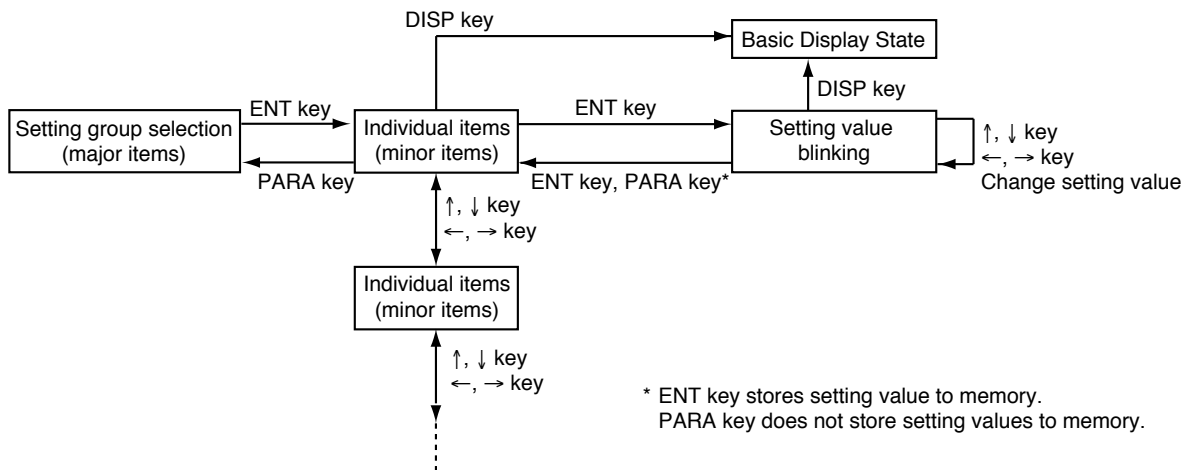
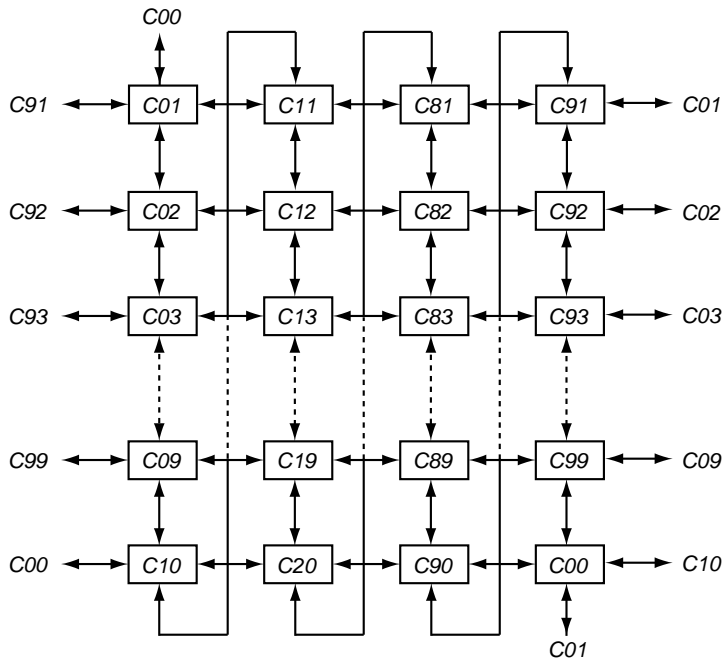

7 - 2 How to Use The PARA key

Use the PARA key for calling up individual items in frequently changed parameters.

■ How to register functions to keys

Up to eight individual items in the parameter setup can be assigned to each PARA key. The assignment item must be registered to use this feature.

This feature allows you to call up individual items more easily in the following order: FUNC key + the PARA key selection of setting group → individual item matrix.

● How to register assignment items

To register an assignment item, add the following base corresponding to the setting group to the item No., and then set the resultant value to setup data C55 to C62 (PARA key assignment items 1 to 8).

Base	Setting Group
1000	Constant-value operation data
1500	PID parameters 1
2000	PID parameters 2
2500	Variable parameters
3000	Variable parameters 2
3500	Event configuration data
4000	Table data
4500	Setup data

● Example

Let's register four individual items to the PARA key. If you press the PARA key in the basic display state, the 1st to 4th individual items in the table below are displayed successively. In this example, let's change the setting values.

Order	Item to Call by PARA key
1	Setup data <i>C01</i>
2	PID parameter <i>P-2</i>
3	Variable parameter <i>FL</i>
4	Variable parameter <i>FASt</i>

The settings for registering these individual items are as follows.
Setup Data Setting "SEt"

No.	Item Code [auxiliary display]	Item	Setting Value	Remarks
55	C55	PARA key assignment item 1	4501	This is produced by adding item No.1 of C01 to setup data radical 4500.
56	C56	PARA key assignment item 2	1511	This is produced by adding item No.11 of P-2 to PID parameter radical 1500.
57	C57	PARA key assignment item 3	2503	This is produced by adding item No.3 of FL to setup data radical 2500.
58	C58	PARA key assignment item 4	2520	This is produced by adding item No.20 of FASt to variable parameter radical 2500.

! Handling Precautions

- For details on item Nos., see “7-3 Parameter Setup List” (pages 7-7 to 7-44).
- When the “PARA key assignment item” setting is set to a value that does not correspond to an existing item, that setting is ignored.
For example, though factory setting 1000 corresponds to “constant-value operation data” 0 of base 1000, 0 does not exist, so the setting will be treated as invalid data and will not be registered.

● Operations by the PARA key

If you press the PARA key in the basic display state, registered individual items are called up. Each press of the PARA key successively calls up (up to eight) registered individual items. Only individual items to which valid assignment settings have been registered can be called up.

PARA key operations are not limited by the setting of the “variable parameter setup” LoC (key lock). PARA key operations are described in the figure shown below.

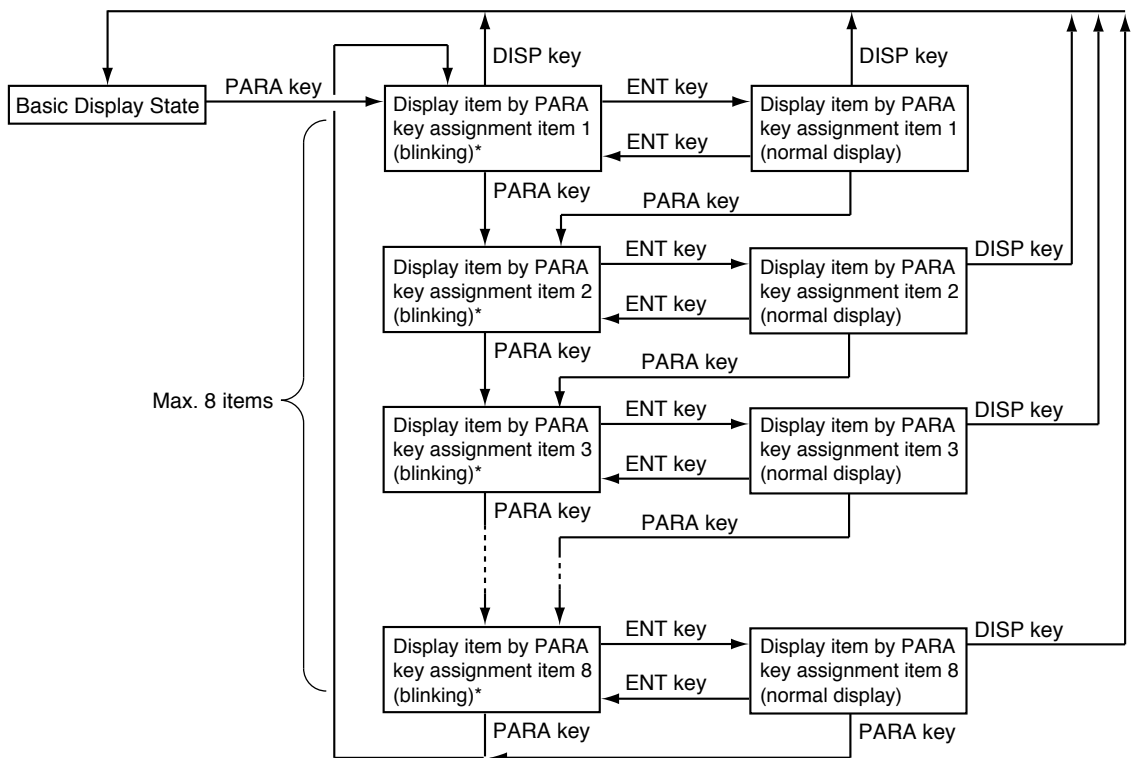

! Handling Precautions

When invalid assignments are registered to an individual item, that item is skipped and the next registered item is displayed.

- * Items that can be changed: When these items are displayed blinking, the setting values can be changed by the ↑, ↓, → and ← key. The ENT key stores data to memory.

Items for reference: These are displayed at all times.

7 - 3 Parameter Setup List

 Note

“U” and “%FS” used in the “Factory Setting” and “Setting” columns in the table mean the following:

U: The decimal point position changes according to the input range type setting. For example, when one digit past the decimal point is allowed, -1999U becomes -199.9, and 9999U becomes 999.9.

%FS: The numbers and decimal point position change according to the input range setting.

For example, when the input range is 0.0 to 800.0°C, 0%FS is 0.0 and 100%FS is 800.0.

Variable parameter settings “PARA”

No.	Item Code	Item	Factory Setting	User Setting	Setting
1	LoC	Key lock	0		0: Key lock disabled 1: Display of setup data settings disabled 2: Display of parameter settings and program settings disabled 3: Use of operation keys disabled 4: Display of parameter settings and program settings displayed, and use of operation keys disabled [Note] Two or more key lock setting values for actual key lock items and items assigned to the PARA key can be displayed and set.
2	PrtC	Program protect	0		0: Changing of program settings enabled 1: Changing of program settings disabled
3	FL	Input 1 digital filter	0.0		0.0 to 120.0 seconds [Note] 0.0 disables the filter.
4	Pbl	Input 1 bias	0U		-1000 to +1000U
5	Sbl	SP1 bias	0U		-1999 to +9999U
6	otL	MV change limiter (CH1)	0.0		0.0 to 10.0% (0.1% second steps) [Note] 0.0 disables the limit.
7	IoUt	PID operation initial MV	0.0 (50.0)		0.0 to 100.0% [Note] On heat/cool models, the factory setting is 50.0.
8	rPid	PID operation initialization	0		0: Automatic judgment of initialization is carried out by advance operation. 1: Initialization is carried out by advance operation. 2: Initialization is not carried out by advance operation.
9	At	Auto-tuning method selection (CH1)	0		0: AT is disabled. 1: General AT is executed. 2: Overshoot-inhibited AT is executed. 3: AT by neural net is executed. [Note] On heat/cool models when setup data C44 setting is 0, “- - -” is displayed, and setting is not possible.
10	St	Smart-tuning method selection (CH1)	0		0: Smart-tuning is disabled. 1: The brake value is fixed to inhibit overshoot. 2: Overshoot is inhibited while automatically reviewing the brake value. [Note] On heat/cool models when setup data C44 setting is 0, “- - -” is displayed, and setting is not possible.
11	2Pid	Advanced PID selection (CH1)	0		0: 2 degrees of freedom PID is disabled. 1: 2 degrees of freedom PID is enabled. [Note] On heat/cool models when setup data C44 setting is 0, “- - -” is displayed, and setting is not possible.
12	gS.t	G.Soak time (CH1)	2.0		0.1 to 60.0 seconds
13	CP.11	PID auto-switching point 1-1	0U		-1999 to +9999U
14	CP.12	PID auto-switching point 1-2	200U		[Note]
15	CP.13	PID auto-switching point 1-3	400U		When setup data C11 setting is 0 (PID set auto-switching OFF), “- - -” is displayed and setting is not possible.
16	CP.14	PID auto-switching point 1-4	600U		-1999 to +9999U
17	CP.15	PID auto-switching point 1-5	800U		[Note]
18	CP.16	PID auto-switching point 1-6	1000U		On heat/cool models when setup data C44 setting is 0, “- - -” is displayed and setting is not possible.
19	CP.17	PID auto-switching point 1-7	1200U		On other models, when setup data C11 setting is 0 (PID set auto-switching OFF), “- - -” is displayed and setting is not possible.
20	FASt	FAST factor	0		0: 2X 1: 10X 2: 60X (10X) 3: 120X (10X) [Note] When setup data C64 setting is 1 (program time unit: minutes/seconds), the FAST factor is 10X for settings 2 and 3.

Chapter 7. PARAMETER SETUP

No.	Item Code	Item	Factory Setting	User Setting	Setting
21	<i>dIFF</i>	Position-proportional dead zone	5.0		0.5 to 25.0% [Note] This setting is displayed on 2G output models. On 2G output model and models other than heat/cool models, “- - -” is displayed and setting is not possible.
		Heat/cool control dead zone	0.0		-100.0 to +50.0% [Note] This setting is displayed on heat/cool models. On 2G output model and models other than heat/cool models, “- - -” is displayed and setting is not possible.
22	<i>CY.1</i>	Output 1 time-proportional output cycle	10		5 to 120 seconds (relay output) 1 to 60 seconds (voltage output) [Note] On models whose output 1 is neither relay output nor voltage output, “- - -” is displayed and setting is not possible.
23	<i>CY.2</i>	Output 2 time-proportional output cycle	10		5 to 120 seconds (relay output) 1 to 60 seconds (voltage output) [Note] On models whose output 2 is neither relay output nor voltage output, “- - -” is displayed and setting is not possible. [Note] “- - -” is displayed and setting is not possible.
24	<i>CY.3</i>	Output 3 time-proportional output cycle	10		1 to 60 seconds [Note] On models whose output 3 is not voltage output, “- - -” is displayed and setting is not possible.
25	<i>dv-L</i>	3-position control deviation lower limit	5U		0 to 1000U [Note]
26	<i>dv-H</i>	3-position control deviation upper limit	5U		On models other than 3D output models, “- - -” is displayed and setting is not possible.
27	<i>HY-L</i>	3-position control lower limit hysteresis	5U		
28	<i>HY-H</i>	3-position control upper limit hysteresis	5U		
29	<i>m-C</i>	Motor control method selection	0		0: MFB control (conventional) + estimated position control 1: MFB control (conventional) only 2: Estimated position control only [Note] On models other than 2G output models, “- - -” is displayed and setting is not possible.
30	<i>m-At</i>	Motor valve opening automatic adjustment	0		0: Adjustment disabled 1: Adjustment enabled [Note] On models other than 2G output models, “- - -” is displayed and setting is not possible. On 2G output models, when <i>m-C</i> setting is 2, “- - -” is displayed and setting is not possible.
31	<i>m-CL</i>	Motor valve opening adjustment fully closed position	1000		0 to (fully open adjustment - 500) [Note] On models other than 2G output models, “- - -” is displayed and setting is not possible. On 2G output models, when <i>m-C</i> setting is 2, “- - -” is displayed and setting is not possible.
32	<i>m-oP</i>	Motor valve opening adjustment fully open position	9000		(fully closed adjustment + 500) to 9999 [Note] On models other than 2G output models, “- - -” is displayed and setting is not possible. On 2G output models, when <i>m-C</i> setting is 2, “- - -” is displayed and setting is not possible.
33	<i>m-t</i>	Motor valve opening adjustment fully open/closed time	30.0		5.0 to 240.0 seconds [Note] On models other than 2G output models, “- - -” is displayed and setting is not possible.

■ Description of variable parameter settings

● LoC (key lock)

- 0: Key lock disabled
- 1: Display of setup data settings disabled
- 2: Display of parameter settings and program settings disabled
- 3: Use of operation keys disabled
- 4: Display of parameter settings and program settings displayed, and use of operation keys disabled
 - When *LoC* is set to 1, the following keys are disabled.
 - Basic display state: FUNC + CLR + DISP keys (general reset)
 - Only *SEt* can not be selected by setting group selection in the parameter setup state.
 - When *LoC* is set to 2, the following keys are disabled.
 - Basic display state: FUNC + PROG keys (program setup)
 - ↑ + PROG key (program copy)
 - FUNC + CLR + DISP keys (general reset)
 - Only *PARA* can be selected by setting group selection in the parameter setup state.
 - However, note that items assigned to the *PARA* key can be called up by the *PARA* key in the basic display state.
 - When *LoC* is set to 3, the following keys are disabled.
 - Basic display state: PROG key (program selection)
 - ↓ (program selection)
 - RUN/HOLD key (RUN, HOLD)
 - PROG + RUN/HOLD keys (RESET)
 - PROG + DISP keys (ADV)
 - FUNC + → keys (FAST)
 - A/M key (AUTO, MANUAL)
 - AT key (AT start, AT cancel)
 - FUNC + CLR + DISP keys (general reset)
 - However, note that *MV* (when the DCP302 is selected for use as a controller) and *SP* (when the DCP302 is selected for use as a programmer) can be changed in the basic display state in the MANUAL mode.
 - When *LoC* is set to 4, all keys disabled when *LoC* is set to 2 and 3 are disabled.

● PrtC (program protect)

- 0: Changing of program settings enabled
 - 1: Changing of program settings disabled
- When *PrtC* is set to 1, the following keys are disabled.
- Basic display state:
 - ↑ + PROG key (program copy)
 - FUNC + CLR + DISP keys (general reset)
 - Program setup state:
 - ENT key (start of value entry)
 - FUNC + ENT keys (segment insert/delete)

● *otL* (MV change limit) (CH1)

The MV is increased or decreased by the same value so that the output change is taken as the limit setting value when the output change (%) after PID operation is greater than this limit setting.

The following example shows the actual change in MV when the MV changes from 20% to 22% with the change limit setting at 0.5%. MV is output at 0.5% setting value increments every 0.1 seconds, and reaches 22% in 0.4 seconds.

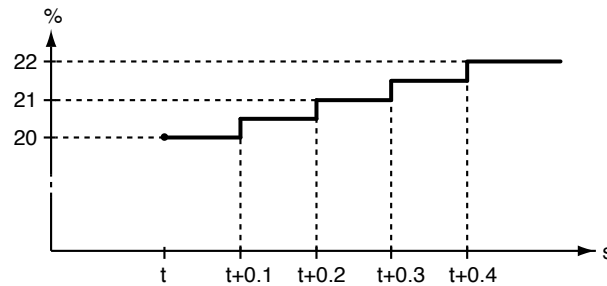

● *IoUt* (PID operation initial MV) (CH1)

PID operation is started in the following cases using the *IoUt* setting value:

- When the mode changes from READY AUTO to RUN AUTO
- When the power is turned ON in the RUN AUTO (or HOLD, FAST, END AUTO) mode
- At completion of auto-tuning

As the PV, SP and PID parameters settings bear a relation to PID operation, the first MV resulting from PID operation will not necessarily match the *IoUt* setting value.

● *rPid* (PID operation initialization) (CH1)

When SP changes suddenly by ADV (advance) operation, rate action in PID operation may cause the MV in the operation to change excessively. For this reason, excessive changes can be suppressed by initializing PID operation.

However, as initialization may result in lost continuity of PID operation, initialization may adversely influence PID operation depending on the circumstances in which the DCP302 is being used.

Initialization ON/OFF and conditions can be selected by the *rPid* setting.

● *St* (smart-tuning method selection) (CH1)

0: Smart-tuning is disabled.

1: The brake value is fixed to inhibit overshoot.

2: Overshoot is inhibited while automatically reviewing the brake value.

- When the control direction is set to reverse action, overshoot is inhibited. When set to direct action, undershoot is inhibited. Both functions are referred to collectively as “overshoot inhibit”.

When set to 1, the value of PID parameter setting item *br* (brake) is used as it is to inhibit overshoot.

When set to 2, the value of *br* is reviewed at each rise (reverse action) or fall (direct action), and overshoot is inhibited while the value is automatically rewritten.

Review is executed only in the direction in which the *br* value is increased (overshoot inhibit effect becomes more apparent).

When operation is carried out for a long time with this parameter set to 2, overshoot inhibit may function too strongly, and it may take a long time to arrive at SP. So, when overshoot disappears, note down the *br* value at that time, set *St* to 1, and reset the *br* value to the noted down value.

- The AT LED lights while the *br* value is reviewed when *St* is set to 2.
- Do not set to 2 when normal control is not being carried out due to inappropriate tuning of the PID constant, for example.
Also, hunting is more likely to occur when *br* is set to a large value on quick-starting lines. Set the *br* value to 0 then to 2.
- The channel that is connected to heat/cool output, smart-tuning does not function.

● 2Pid (2 degrees of freedom) (CH1)

0: 2 degrees of freedom is disabled.

1: 2 degrees of freedom is enabled.

- 2 degrees of freedom is a function for improving the response to disturbance during setup without losing conventional characteristics at rise (or fall).
When set to 1, optimum PID constants can be set individually for inhibiting disturbance in addition to conventional PID constants.
These constants are set automatically during AT execution, and are memorized. They can also be set and changed independently.
In particular, on 2G output models, suppressing changes in MV to lessen the frequency of motor operation during setup, and manually applying weak PID differential for inhibiting disturbance to lengthen service life, for example, prove effective.
- These PID are switched automatically by applying fuzzy rules on the slope between deviation and PV.
- When *I* (reset time) is set to 0, control is carried out without integration in all states regardless of the setting value of *dl* (disturbance inhibit reset time).
- On the channel which is connected to heat/cool output, 2 degrees of freedom does not function.

● dIFF

- Position-proportional control dead zone

On 2G output models, a dead zone between the motor open and motor closed positions is set.

As a general guideline, the minimum value is the value where this dead zone changes to stop motor hunting once a fixed value set to manual output is being output.

If this value is set without any margin, the motor will be operating at all times, which will considerably shorten its service life.

The factory setting is 5%. Use this as a guideline, and take the control results and motor service life into consideration when setting the dead zone.

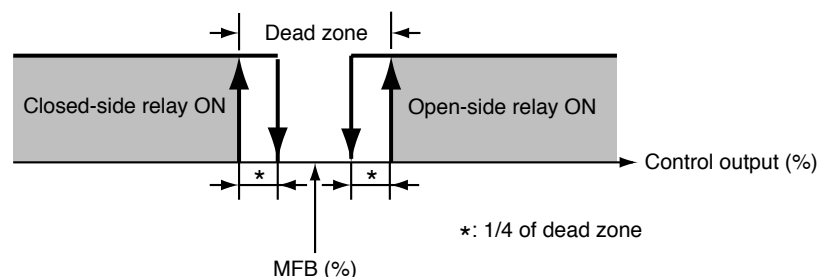

• Heat/cool control dead zone

The figure below shows the heat/cool output control operation:

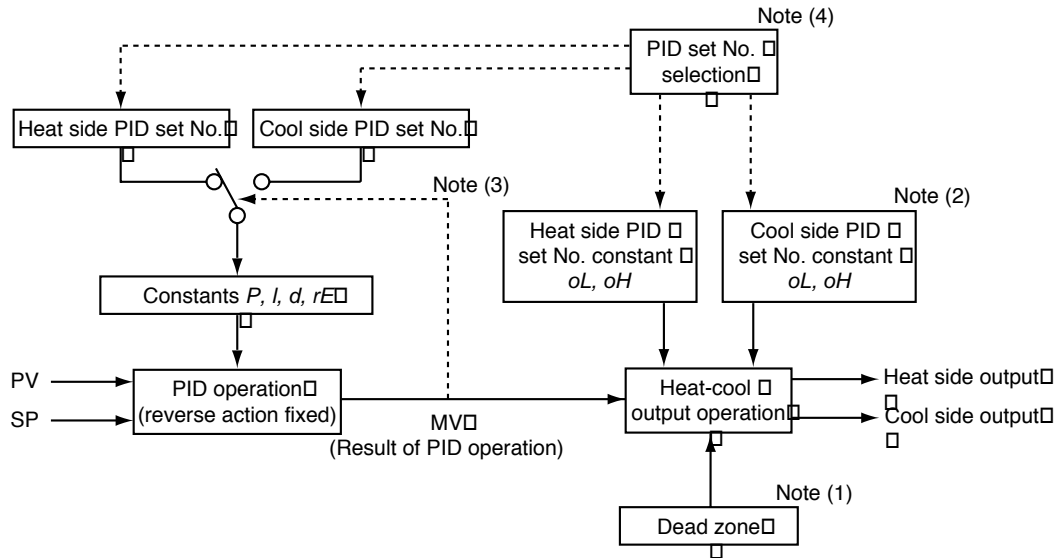

Note (1) On heat/cool models, this parameter sets how the relationship between heat-side output and cool-side output should be processed with respect to the MV resulting from PID operation.

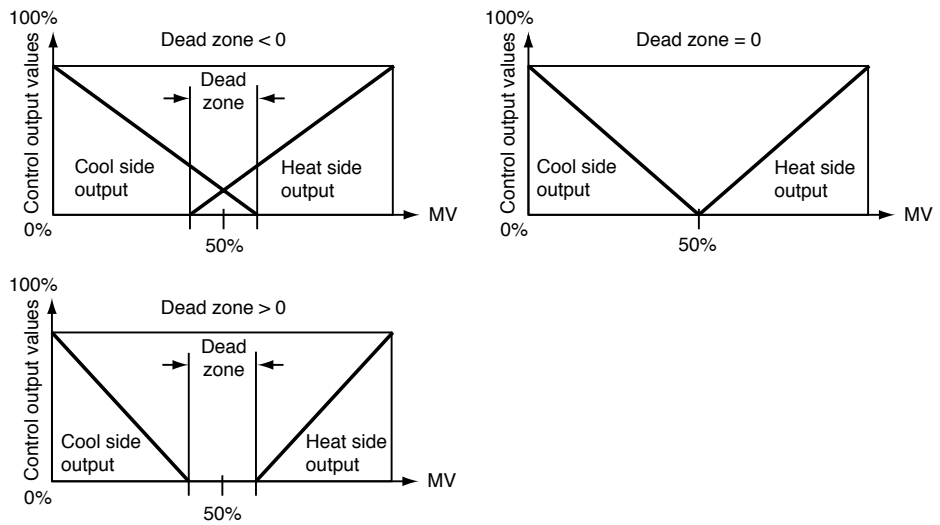

Note (2) Constants oL and oH functions as follows:

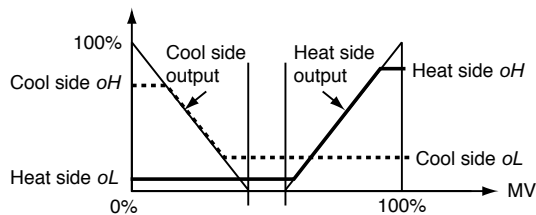

Note (3) When MV is greater than or equal to 50%, the PID set on the heat side is switched to.

When MV is less than 50%, the PID set on the cool side is switched to.

Note (4) PID set selection is carried out by setting values or by external switch input.

- *dv-L* (3-position control deviation lower limit)
- *dv-H* (3-position control deviation upper limit)
- *HY-L* (3-position control lower limit hysteresis)
- *HY-H* (3-position control upper limit hysteresis)

In 3-position control, control is carried out in the following three states in the RUN, HOLD, FAST and END modes.

State	Heat-side	Cool-side	MV
1	OFF (0.0%)	ON (100.0%)	0.0%
2	OFF (0.0%)	OFF (0.0%)	50.0%
3	ON (100.0%)	OFF (0.0%)	100.0%

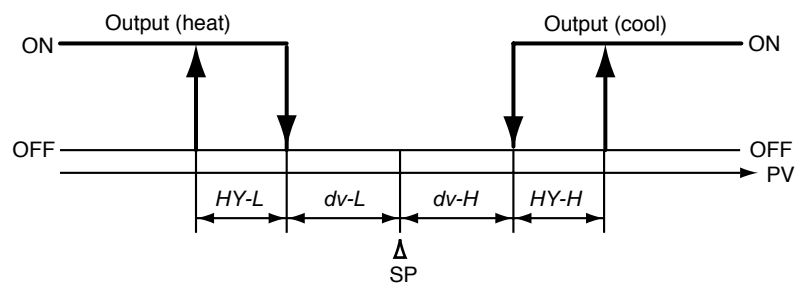

! Handling Precautions

Even in 3-position control, output is time-proportional in the READY mode when setup data *C44* setting is 0. This is set in setup data *C16* (MV (heat) in READY mode) and *C17* (MV (cool) in READY mode).

Output is time-proportional output when setup data *C44* setting is 1. This is set to setup data *C39* (MV2 (heat) in READY mode) and *C40* (MV2 (cool) in READY mode).

When connecting an actuator that may burn by time-proportional output, set setup data *C16* and *C17* or *C39* and *C40* so that output in the READY mode is 0%.

● ***m-C* (motor control method selection)**

0: MFB control (conventional) + estimated position control

1: MFB control (conventional) only

2: Estimated position control only (without MFB)

- 0: MFB control (conventional) + estimated position control
 - When MFB (Motor Feed Back) input is normal, the motor position is controlled by the actually measured MFB.
 - When MFB input is in error, the motor position is controlled by an estimated MFB value. This state is referred to as "estimated position control state." For example, when the motor rotates at a position where the feedback potentiometer has deteriorated, MFB input changes suddenly. This sudden change is detected as an error, and the correct MFB position is estimated. The motor position is also controlled by the estimated MFB value when the MFB disconnected alarm has occurred.
 - In the estimated position control state, an error will inevitably occur between the actual motor valve opening and estimated MFB value. So, set the closed-side relay to ON at all times when output (MV) is less than or equal to 0.0%, and the open-side relay to ON at all times when MV is greater than or equal to 100.0% to set the motor to a fully-open or fully-closed state to compensate this error. However, note that this error is not compensated when MV is limited to within 0.1 to 99.9% by the output limiter, or when MV is 0.0% or less or 100% or more due to the control state.
 - The following are probable causes when estimated position control is likely to be carried out:
 - Defective motor valve opening adjustment
 - Deteriorated feedback potentiometer, insufficient resolution
 - Defective MFB wiring.
- 1: MFB control (conventional) only
 - When this setting is used, conventional MFB control is carried out. When the MFB disconnected alarm occurs, the MFB value is regarded as 150.0%, and the closed-side relay is ON at all times.
- 2: Estimated position control only
 - When this setting is used, control is in the estimated position control state at all times, and the motor position is controlled by the estimated MFB value regardless of the state of MFB wiring.
 - When this setting is used, enter the correct *m-t* item.
 - The MFB disconnected alarm does not occur.
 - The error between actual motor valve opening and estimated MFB value is compensated by forcibly continuing motor operation in the closed or open directions when MV is 0.0% and 100%.

- ***m-At* (motor valve opening automatic adjustment)**

0: Adjustment disabled

1: Adjustment enabled

This parameter automatically measures the motor fully closed position, fully open position, and close-open times. The results of calculation are automatically written to *m-CL*, *m-oP* and *m-t*.

- Adjustment Method and Motor Functions

1. Set *m-C* to 0 or 1.

2. Set *m-At* to 1, and press the ENT key .

If set to 1 already, press the ENT key twice to enter automatic adjustment.

3. Automatic adjustment is carried out.

- *CA.CL* is displayed on the upper display, and the closed-side relay turns ON.

- The motor operates to the closed side, and the MFB count value is displayed on the lower display. When the count has stabilized, fully closed adjustment is completed, and the count value is written to *m-CL*.

- *CA.oP* is displayed on the upper display, and the closed-side relay turns ON.

- The motor operates to the open side, and the MFB count value is displayed on the lower display. When the count has stabilized, fully open adjustment is completed, and the count value is written to *m-oP*.

The time it took from fully closed to fully open is written to *m-t*. However, note that if this time is 240.0 seconds or more, the time is taken as 240.0 seconds.

- When all adjustments are completed, the DCP302 returns to the basic display state.

4. To cancel automatic adjustment, press the DISP key.

When automatic adjustment begins, you cannot press any keys other than the DISP key. The DISP key is used for canceling adjustment.

The following instances are regarded as errors. In these instances, the factory settings are returned to, and *AL 12* is displayed. The *AL 12* display can be cleared only when automatic re-adjustment has ended successfully or when the power has been reset.

- Fully closed count - fully open count is less than 500

- Fully closed count is greater than fully open count

- Time from fully closed to fully open is less than 5 seconds

- MFB disconnected alarm (*AL 10*, *AL 11*) occurs continuously or frequently

- The time taken for the MFB count to stabilize exceeds 5 minutes

- Faulty wiring of MFB or switching relay

(However, note that all faulty wiring cannot be detected as an error.)

- ***m-t* (motor valve opening adjustment fully open/closed time)**

When *m-C* is set to 2, the set time is taken as the base for all operations. Enter the time correctly in 0.1 second units.

■ Variable parameter 2 settings “*PAR2*”

No.	Item Code	Item	Factory Setting	User Setting	Setting
1	<i>FL.2</i>	Input 2 digital filter	0.0		0.0 to 120.0 seconds [Note] 0.0 disables the filter.
2	<i>Pbl.2</i>	Input 2 bias	0U		-1000 to +1000U
3	<i>Sbl.2</i>	SP2 bias	0U 0.0%RH		-1000 to +1000U (PV2 input model) -100.0 to +100.0%RH (temperature/humidity operation mode)
4	<i>PrSS</i>	Pressure offset	1013		670 to 1330 hPa [Note] • On PV2 channel models, “- - -” is displayed, and setting is not possible. • Set the pressure offset of the relative humidity operation. Normally, set air pressure (1013 hPa).
5	<i>vEL</i>	Velocity offset	0		0: Large (2.5 m/s min.) 1: Medium (0.5 to 2.5 m/s) 2: Small (less than 0.5 m/s) [Note] • On PV2 channel models, “- - -” is displayed, and setting is not possible. • Set the velocity offset of the relative humidity operation. Normally, set to “0”.
6	<i>t-b1</i>	Unused	—		[Note]
7	<i>gASS</i>	Unused	—		“- - -” is displayed, and setting is not possible.
8	<i>otL.2</i>	MV change limiter (CH2)	0.0		0.0 to 10.0% (0.1 second steps) [Note] 0.0 disables the limit.
9	<i>lot.2</i>	PID operation initial MV (CH2)	0.0		0.0 to 100.0%
10	<i>rPl.2</i>	PID operation initialization (CH2)	0		0: Automatic judgment of initialization is carried out by advance operation. 1: Initialization is carried out by advance operation. 2: Initialization is not carried out by advance operation.
11	<i>At.2</i>	Auto-tuning method selection (CH2)	0		0: AT is disabled. 1: General AT is executed. 2: Overshoot-inhibited AT is executed. 3: AT by neural net is executed. [Note] On heat/cool models and setup data <i>C44</i> setting is 1, “- - -” is displayed, and setting is not possible.
12	<i>St.2</i>	Smart-tuning method selection (CH2)	0		0: Smart-tuning is disabled. 1: The brake value is fixed to inhibit overshoot. 2: Overshoot is inhibited while automatically reviewing the brake value. [Note] On heat/cool models and setup data <i>C44</i> setting is 1, “- - -” is displayed, and setting is not possible.
13	<i>2Pl.2</i>	Advanced PID selection (CH2)	0		0: 2 degrees of freedom PID is disabled. 1: 2 degrees of freedom PID is enabled. [Note] On heat/cool models and setup data <i>C44</i> setting is 1, “- - -” is displayed, and setting is not possible.
14	<i>gSt.2</i>	G.SoaK time (CH2)	2.0		0.1 to 60.0 seconds
15	<i>CH.2</i>	Add basic display item (CH2)	0		0: Add disabled 1: Add PV2 + PVw display. 2: Add PVw + SPw display. [Note] • On PV2 channel models, “- - -” is displayed, and setting is not possible.
16	<i>CP.21</i>	PID auto-switching point 2-1	0U		-1999 to +9999U [Note]
17	<i>CP.22</i>	PID auto-switching point 2-2	200U		When setup data <i>C34</i> setting is 0 (PID set auto-switching OFF), “- - -” is displayed and setting is not possible.
18	<i>CP.23</i>	PID auto-switching point 2-3	400U		

No.	Item Code	Item	Factory Setting	User Setting	Setting
19	CP.24	PID auto-switching point 2-4	600U		-1999 to +9999U [Note] When setup data C34 setting is 0 (PID set auto-switching OFF), “- - -” is displayed and setting is not possible. On heat/cool models and setup data C44 setting is 1 (PID set auto-switching OFF), “- - - -” is displayed, and setting is not possible.
20	CP.25	PID auto-switching point 2-5	800U		
21	CP.26	PID auto-switching point 2-6	1000U		
22	CP.27	PID auto-switching point 2-7	1200U		

■ Details on variable parameter 2

● *otL*2 (MV change limiter) (CH2)

See variable parameter *otL* (page 7-10).

● *lot*.2 (PID operation initial MV) (CH2)

See variable parameter *loUt* (page 7-10).

● *rPI*.2 (PID operation initialization) (CH2)

See variable parameter *rPId* (page 7-10).

● *St*.2 (smart-tuning method selection) (CH2)

See variable parameter *St* (page 7-10).

● *2PI*.2 (advanced PID selection) (CH2)

See variable parameter *2PId* (page 7-11).

■ Event configuration data settings “Eu”

No.	Item Code	Item	Factory Setting	User Setting	Setting
1	<i>Et1</i>	Event 1 type	0		<p><u>PV type events</u> 0: PV1 direct 1: PV1 reverse 2: Deviation 1 direct 3: Deviation 1 reverse 4: Absolute value deviation 1 direct 5: Absolute value deviation 1 reverse 6: SP1 direct 7: SP1 reverse 8: MV1 direct 9: MV1 reverse 10: MFB direct 11: MFB reverse 12: PV2 direct 13: PV2 reverse 14: Deviation 2 direct 15: Deviation 2 reverse 16: Absolute value deviation 2 direct 17: Absolute value deviation 2 reverse 18: SP2 direct 19: SP2 reverse 20: MV2 direct 21: MV2 reverse 22: PVw direct 23: PVw reverse 24 to 25: NOP 26: SPw direct 27: SPw reverse 28 to 49: NOP</p> <p><u>Time events</u> 50: Time event 51 to 99: NOP</p> <p><u>Controller status events</u> 100: RUN+HOLD+FAST+END 101: READY 102: RUN 103: HOLD 104: FAST 105: END 106: G.Soak standby (logical OR of CH1 and CH2) 107: MANUAL (logical OR of CH1 and CH2) 108: Auto-tuning executing (logical OR of CH1 and CH2) 109: Constant-value operation 110: MFB estimated position control 111: Logical OR of all alarms 112: PV range alarm 113: Controller alarm 114: Low battery voltage 115: Console setup in progress 116: Loader setup in progress 117: ADV (ON time 1 second) 118: NOP 119: G.Soak standby (CH1) 120: G.Soak standby (CH2) 121: MANUAL (CH1) 122: MANUAL (CH2) 123: Auto-tuning executing (CH1) 124: Auto-tuning executing (CH2) 125 to 199: NOP</p> <p>[Note] Setting can be changed only in READY mode.</p>

No.	Item Code	Item	Factory Setting	User Setting	Setting
2	<i>Ed1</i>	Event 1 standby	0		0: Standby OFF 1: Standby ON [Note] The controller stands by after power is restored and in the READY mode. When the event type setting is ≥ 50 , “- - - -” is displayed and setting is not possible.
3	<i>HYS1</i>	Event 1 hysteresis	5		0 to 200U (when event type is neither MV nor MFB) 0.0 to 20.0% (when event type is MV or MFB) [Note] When the event type setting is ≥ 50 , “- - - -” is displayed and setting is not possible.
4	<i>dLt</i>	Event 1 ON delay time	0		0 to 3600 seconds

Chapter 7. PARAMETER SETUP

No.	Item Code	Item	Factory Setting	User Setting	Setting
5	Et2	Event 2 type	0		<p><u>PV type events</u> 0: PV1 direct 1: PV1 reverse 2: Deviation 1 direct 3: Deviation 1 reverse 4: Absolute value deviation 1 direct 5: Absolute value deviation 1 reverse 6: SP1 direct 7: SP1 reverse 8: MV1 direct 9: MV1 reverse 10: MFB direct 11: MFB reverse 12: PV2 direct 13: PV2 reverse 14: Deviation 2 direct 15: Deviation 2 reverse 16: Absolute value deviation 2 direct 17: Absolute value deviation 2 reverse 18: SP2 direct 19: SP2 reverse 20: MV2 direct 21: MV2 reverse 22: PVw direct 23: PVw reverse 24 to 25: NOP 26: SPw direct 27: SPw reverse 28 to 49: NOP</p> <p><u>Time events</u> 50: Time event 51 to 99: NOP</p> <p><u>Controller status events</u> 100: RUN+HOLD+FAST+END 101: READY 102: RUN 103: HOLD 104: FAST 105: END 106: G.Soak standby (logical OR of CH1 and CH2) 107: MANUAL (logical OR of CH1 and CH2) 108: Auto-tuning executing (logical OR of CH1 and CH2) 109: Constant-value operation 110: MFB estimated position control 111: Logical OR of all alarms 112: PV range alarm 113: Controller alarm 114: Low battery voltage 115: Console setup in progress 116: Loader setup in progress 117: ADV (ON time 1 second) 118: NOP 119: G.Soak standby (CH1) 120: G.Soak standby (CH2) 121: MANUAL (CH1) 122: MANUAL (CH2) 123: Auto-tuning executing (CH1) 124: Auto-tuning executing (CH2) 125 to 199: NOP</p> <p>[Note] Setting can be changed only in READY mode.</p>

No.	Item Code	Item	Factory Setting	User Setting	Setting
6	<i>Ed2</i>	Event 2 standby	0		0: Standby OFF 1: Standby ON [Note] The controller stands by after power is restored and in the READY mode. When the event type setting is ≥ 50 , “- - - -” is displayed and setting is not possible.
7	<i>HYS2</i>	Event 2 hysteresis	5		0 to 200U (when event type is neither MV nor MFB) 0.0 to 20.0% (when event type is MV or MFB) [Note] When the event type setting is ≥ 50 , “- - - -” is displayed and setting is not possible.
8	<i>dL2</i>	Event 2 ON delay time	0		0 to 3600 seconds

Chapter 7. PARAMETER SETUP

No.	Item Code	Item	Factory Setting	User Setting	Setting
9	Et3	Event 3 type	0		<p><u>PV type events</u> 0: PV1 direct 1: PV1 reverse 2: Deviation 1 direct 3: Deviation 1 reverse 4: Absolute value deviation 1 direct 5: Absolute value deviation 1 reverse 6: SP1 direct 7: SP1 reverse 8: MV1 direct 9: MV1 reverse 10: MFB direct 11: MFB reverse 12: PV2 direct 13: PV2 reverse 14: Deviation 2 direct 15: Deviation 2 reverse 16: Absolute value deviation 2 direct 17: Absolute value deviation 2 reverse 18: SP2 direct 19: SP2 reverse 20: MV2 direct 21: MV2 reverse 22: PVw direct 23: PVw reverse 24 to 25: NOP 26: SPw direct 27: SPw reverse 28 to 49: NOP</p> <p><u>Time events</u> 50: Time event 51 to 99: NOP</p> <p><u>Controller status events</u> 100: RUN+HOLD+FAST+END 101: READY 102: RUN 103: HOLD 104: FAST 105: END 106: G.Soak standby (logical OR of CH1 and CH2) 107: MANUAL (logical OR of CH1 and CH2) 108: Auto-tuning executing (logical OR of CH1 and CH2) 109: Constant-value operation 110: MFB estimated position control 111: Logical OR of all alarms 112: PV range alarm 113: Controller alarm 114: Low battery voltage 115: Console setup in progress 116: Loader setup in progress 117: ADV (ON time 1 second) 118: NOP 119: G.Soak standby (CH1) 120: G.Soak standby (CH2) 121: MANUAL (CH1) 122: MANUAL (CH2) 123: Auto-tuning executing (CH1) 124: Auto-tuning executing (CH2) 125 to 199: NOP</p> <p>[Note] Setting can be changed only in READY mode.</p>

No.	Item Code	Item	Factory Setting	User Setting	Setting
10	<i>Ed3</i>	Event 3 standby	0		0: Standby OFF 1: Standby ON [Note] The controller stands by after power is restored and in the READY mode. When the event type setting is ≥ 50 , “- - - -” is displayed and setting is not possible.
11	<i>HYS3</i>	Event 3 hysteresis	5		0 to 200U (when event type is neither MV nor MFB) 0.0 to 20.0% (when event type is MV or MFB) [Note] When the event type setting is ≥ 50 , “- - - -” is displayed and setting is not possible.
12	<i>dL3</i>	Event 3 ON delay time	0		0 to 3600 seconds
13	<i>tt</i>	Time event type	0		0: T1 to T5 are all time events. 1: T1 is a segment No. event. T2 to T5 are time events. 2: T1 and T2 are segment No. events. T3 to T5 are time events. 3: T1 to T3 are segment No. events. T4 and T5 are time events. 4: T1 to T4 are segment No. events. T5 is a time event. 5: All T1 to T5 are segment No. events. [Note] On models not supporting time events, “- - - -” is displayed and setting is not possible. Settings can be changed only in the READY mode.

■ Description of event configuration data

- *Ed1* (event 1 standby)
- *Ed2* (event 2 standby)
- *Ed3* (event 3 standby)

0: Standby OFF
 1: Standby ON

- When set to standby ON, event output becomes OFF if the DCP302 is in the standby state even if the condition for turning event output ON is satisfied.
- The DCP302 enters the standby state in the following instances:
 When in the READY mode
 When moving from the READY to the RUN mode
 When the power is turned ON
- The standby state is canceled in the following instances:
 When the condition for turning event output OFF (not including the hysteresis period) is satisfied in one of the RUN, HOLD or FAST modes
 When set to standby OFF
- In the following example, PV event direct, operating point 500°C, hysteresis 10°C and standby ON are set. When the mode changes from READY to the RUN mode at PV 550°C, the DCP302 enters the standby state, so event output is turned OFF.
 Once PV falls to less than 490°C, standby is canceled, so event output is turned ON when the PV rises to 500°C or above from then on.
- Standby functions only when the event type is set to PV type event, and does not function when set to time event type or controller status type.

- *dL1* (event 1 ON delay time)
- *dL2* (event 2 ON delay time)
- *dL3* (event 3 ON delay time)

- The ON delay time is processed after completing all processes up to event output standby ON/OFF. Event output is turned ON when more than the ON delay time has elapsed with the condition for turning event output ON satisfied.
- When the event type is set to ADV, the ON delay function does not operate whatever value is set as the ON delay time.
- ON delay time is processed as follows.

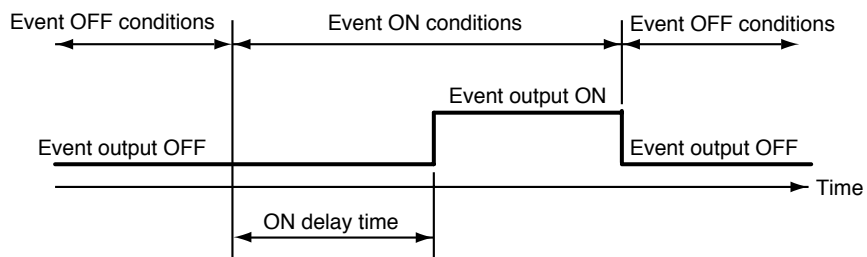

■ PID parameter 1 settings “*PId*”

No.	Item Code	Item	Factory Setting	User Setting	Setting															
1	<i>P-1</i>	Proportional band (PID set 1-1)	100.0		<p><i>P</i> : 0.1 to 999.9% <i>I</i> : 0 to 3600 seconds 0 disables integrating action. <i>d</i> : 0 to 1200 seconds 0 disables derivative action. <i>oL</i> : -10.0 to +MV upper limit % <i>oH</i> : MV lower limit to +110.0% <i>rE</i> : 0.0 to 100.0% <i>br</i> : 0 to 30 0 disables the brake function. <i>dP</i> : 0.1 to 999.9% <i>dI</i> : 1 to 3600 seconds <i>dd</i> : 0 to 1200 seconds [Note] • These parameters are used for control of CH1. • When variable parameter <i>m-C</i> setting is 2 (estimated position control only) on 2G output models when setup data <i>C44</i> setting is 0, “- - -” is displayed for items <i>oL</i> and <i>oH</i>, and setting is not possible. • When <i>I</i> setting is not 0, “- - -” is displayed for <i>rE</i> and setting is not possible. • When variable parameter <i>St</i> setting is 0 (smart-tuning disabled), “- - -” is displayed for <i>br</i> and setting is not possible. • When variable parameter <i>2PID</i> setting is 0 (2 degrees of freedom PID disabled), the items for <i>dP</i>, <i>dI</i>, <i>dd</i> are not displayed. • The following table shows the PID parameter set Nos. that are used for PID operation on heat/cool models when setup data <i>C44</i> setting is 0.</p> <table border="1" style="margin: 10px auto;"> <thead> <tr> <th>PID Set No. Designated in Program or Zone No. by PID Set Auto-switching</th> <th>PID Set (heat)</th> <th>PID Set (cool)</th> </tr> </thead> <tbody> <tr> <td>1</td> <td>1-1</td> <td>1-2</td> </tr> <tr> <td>2</td> <td>1-3</td> <td>1-4</td> </tr> <tr> <td>3</td> <td>1-5</td> <td>1-6</td> </tr> <tr> <td>4</td> <td>1-7</td> <td>1-8</td> </tr> </tbody> </table> <p>• When variable parameter <i>2PID</i> setting is 1 (2 degrees of freedom PID enabled), the parameter (<i>P</i>, <i>I</i>, <i>d</i>) ideal for control when SP changes and the parameter (<i>dP</i>, <i>dI</i>, <i>dd</i>) ideal for inhibiting disturbance during settling are automatically switched. • Decreasing the proportional band (<i>P</i>, <i>dP</i>) value improves controllability. However, it also makes overshoot or hunting more likely to occur. Use of the controller on a motor or actuator shortens the controller's life. Do not set the proportional band (<i>P</i>, <i>dP</i>) to too small a value. • Decreasing the reset time (<i>I</i>, <i>dI</i>) improves trackability. However, it also makes cycling caused by integrating action more likely to occur. When <i>I</i> setting is 0, integrating operation for inhibiting disturbance also functions. • Increasing the rate time (<i>d</i>, <i>dd</i>) allows overshoot to be inhibited more easily. However, it also make hunting more likely to occur as the controller reacts to minute changes in PV. In a temperature control system, setting the rate time to 1/3 to 1/4 of the integrating time is generally considered to be appropriate. In a pressure or flow rate control system, derivative action causes hunting. Either set the <i>d</i> setting to 0.0 to disable derivative action, or decrease the setting to inhibit hunting.</p>	PID Set No. Designated in Program or Zone No. by PID Set Auto-switching	PID Set (heat)	PID Set (cool)	1	1-1	1-2	2	1-3	1-4	3	1-5	1-6	4	1-7	1-8
PID Set No. Designated in Program or Zone No. by PID Set Auto-switching	PID Set (heat)	PID Set (cool)																		
1	1-1	1-2																		
2	1-3	1-4																		
3	1-5	1-6																		
4	1-7	1-8																		
2	<i>I-1</i>	Reset time (PID set 1-1)	0																	
3	<i>d-1</i>	Rate time (PID set 1-1)	0																	
4	<i>oL-1</i>	MV lower limit (PID set 1-1)	0.0																	
5	<i>oH-1</i>	MV upper limit (PID set 1-1)	100.0																	
6	<i>rE-1</i>	Manual reset (PID set 1-1)	50.0																	
7	<i>br-1</i>	Brake (PID set 1-1)	0																	
8	<i>dP-1</i>	Disturbance inhibit proportional band (PID set 1-1)	100.0																	
9	<i>dI-1</i>	Disturbance inhibit reset time (PID set 1-1)	120																	
10	<i>dd-1</i>	Disturbance inhibit rate time (PID set 1-1)	0																	
11	<i>P-2</i>	Proportional band (PID set 1-2)	100.0																	
12	<i>I-2</i>	Reset time (PID set 1-2)	0.0																	
13	<i>d-2</i>	Rate time (PID set 1-2)	0																	
14	<i>oL-2</i>	MV lower limit (PID set 1-2)	0.0																	
15	<i>oH-2</i>	MV upper limit (PID set 1-2)	100.0																	
16	<i>rE-2</i>	Manual reset (PID set 1-2)	50.0																	
17	<i>br-2</i>	Brake (PID set 1-2)	0																	
18	<i>dP-2</i>	Disturbance inhibit proportional band (PID set 1-2)	100.0																	
19	<i>dI-2</i>	Disturbance inhibit reset time (PID set 1-2)	120																	
20	<i>dd-2</i>	Disturbance inhibit rate time (PID set 1-2)	0																	
21	<i>p-3</i>	Proportional band (PID set 1-3)	100.0																	
22	<i>I-3</i>	Reset time (PID set 1-3)	0.0																	
23	<i>d-3</i>	Rate time (PID set 1-3)	0																	
24	<i>oL-3</i>	MV lower limit (PID set 1-3)	0.0																	
25	<i>oH-3</i>	MV upper limit (PID set 1-3)	100.0																	
26	<i>rE-3</i>	Manual reset (PID set 1-3)	50.0																	
27	<i>br-3</i>	Brake (PID set 1-3)	0																	

Chapter 7. PARAMETER SETUP

No.	Item Code	Item	Factory Setting	User Setting	Setting
28	<i>dP</i> - 3	Disturbance inhibit proportional band (PID set 1-3)	100.0		<ul style="list-style-type: none"> • The MV upper and lower limits (<i>oL</i>, <i>oH</i>) function as integrating limits. When the MV reaches the upper or lower limit, integration no longer functions. This prevents reset wind-up that occurs when the PV has not risen for a long time. • Manual reset (<i>rE</i>) is a setting for eliminating offset that occurs during proportional action (integrated action disabled). For manual reset, set the MV ideal for deviation 0. • Increasing the brake (<i>br</i>) value increases the overshoot inhibit effect. However, it also lengthens the rise time.
29	<i>dl</i> - 3	Disturbance inhibit reset time (PID set 1-3)	120		
30	<i>dd</i> - 3	Disturbance inhibit rate time (PID set 1-3)	0		
31	<i>P</i> - 4	Proportional band (PID set 1-4)	100.0		
32	<i>I</i> - 4	Reset time (PID set 1-4)	0.0		
33	<i>d</i> - 4	Rate time (PID set 1-4)	0		
34	<i>oL</i> - 4	MV lower limit (PID set 1-4)	0.0		
35	<i>oH</i> - 4	MV upper limit (PID set 1-4)	100.0		
36	<i>rE</i> - 4	Manual reset (PID set 1-4)	50.0		
37	<i>br</i> - 4	Brake (PID set 1-4)	0		
38	<i>dP</i> - 4	Disturbance inhibit proportional band (PID set 1-4)	100.0		
39	<i>dl</i> - 4	Disturbance inhibit reset time (PID set 1-4)	120		
40	<i>dd</i> - 4	Disturbance inhibit rate time (PID set 1-4)	0		
41	<i>P</i> - 5	Proportional band (PID set 1-5)	100.0		
42	<i>I</i> - 5	Reset time (PID set 1-5)	0.0		
43	<i>d</i> - 5	Rate time (PID set 1-5)	0		
44	<i>oL</i> - 5	MV lower limit (PID set 1-5)	0.0		
45	<i>oH</i> - 5	MV upper limit (PID set 1-5)	100.0		
46	<i>rE</i> - 5	Manual reset (PID set 1-5)	50.0		
47	<i>br</i> - 5	Brake (PID set 1-5)	0		
48	<i>dP</i> - 5	Disturbance inhibit proportional band (PID set 1-5)	100.0		
49	<i>dl</i> - 5	Disturbance inhibit reset time (PID set 1-5)	120		
50	<i>dd</i> - 5	Disturbance inhibit rate time (PID set 1-5)	0		
51	<i>P</i> - 6	Proportional band (PID set 1-6)	100.0		
52	<i>I</i> - 6	Reset time (PID set 1-6)	0.0		
53	<i>d</i> - 6	Rate time (PID set 1-6)	0		
54	<i>oL</i> - 6	MV lower limit (PID set 1-6)	0.0		

No.	Item Code	Item	Factory Setting	User Setting	Setting
55	<i>oH - 6</i>	MV upper limit (PID set 1-6)	100.0		
56	<i>rE - 6</i>	Manual reset (PID set 1-6)	50.0		
57	<i>br - 6</i>	Brake (PID set 1-6)	0		
58	<i>dP - 6</i>	Disturbance inhibit proportional band (PID set 1-6)	100.0		
59	<i>dl - 6</i>	Disturbance inhibit reset time (PID set 1-6)	120		
60	<i>dd - 6</i>	Disturbance inhibit rate time (PID set 1-6)	0		
61	<i>P - 7</i>	Proportional band (PID set 1-7)	100.0		
62	<i>I - 7</i>	Reset time (PID set 1-7)	0.0		
63	<i>d - 7</i>	Rate time (PID set 1-7)	0		
64	<i>oL - 7</i>	MV lower limit (PID set 1-7)	0.0		
65	<i>oH - 7</i>	MV upper limit (PID set 1-7)	100.0		
66	<i>rE - 7</i>	Manual reset (PID set 1-7)	50.0		
67	<i>br - 7</i>	Brake (PID set 1-7)	0		
68	<i>dP - 7</i>	Disturbance inhibit proportional band (PID set 1-7)	100.0		
69	<i>dl - 7</i>	Disturbance inhibit reset time (PID set 1-7)	120		
70	<i>dd - 7</i>	Disturbance inhibit rate time (PID set 1-7)	0		
71	<i>P - 8</i>	Proportional band (PID set 1-8)	100.0		
72	<i>I - 8</i>	Reset time (PID set 1-8)	0.0		
73	<i>d - 8</i>	Rate time (PID set 1-8)	0		
74	<i>oL - 8</i>	MV lower limit (PID set 1-8)	0.0		
75	<i>oH - 8</i>	MV upper limit (PID set 1-8)	100.0		
76	<i>rE - 8</i>	Manual reset (PID set 1-8)	50.0		
77	<i>br - 8</i>	Brake (PID set 1-8)	0		
78	<i>dP - 8</i>	Disturbance inhibit proportional band (PID set 1-8)	100.0		
79	<i>dl - 8</i>	Disturbance inhibit reset time (PID set 1-8)	120		
80	<i>dd - 8</i>	Disturbance inhibit rate time (PID set 1-8)	0		

■ PID parameter 2 settings “*PId2*”

No.	Item Code	Item	Factory Setting	User Setting	Setting															
1	<i>P</i> - 21	Proportional band (PID set 2-1)	100.0		<p><i>P</i> : 0.0 to 999.9% <i>I</i> : 0 to 3600 seconds 0 disables integrating action. <i>d</i> : 0 to 1200 seconds 0 disables derivative action. <i>oL</i> : -10.0 to MV upper limit % <i>oH</i> : MV lower limit to 110.0% <i>rE</i> : 0.0 to 100.0% <i>br</i> : 0 to 30 0 disables the brake function. <i>dP</i> : 0.1 to 999.9% <i>dI</i> : 1 to 3600 seconds <i>dd</i> : 0 to 1200</p> <p>[Note]</p> <ul style="list-style-type: none"> • These parameters are used for control of CH2. • When variable parameter <i>m-C</i> setting is 2 (estimated position control only) on 2G output models when setup data <i>C44</i> setting is 1, “- - -” is displayed for items <i>oL</i> and <i>oH</i>, and setting is not possible. • When <i>I</i> setting is not 0, “- - -” is displayed for <i>rE</i> and setting is not possible. • When variable parameter 2 <i>St.2</i> setting is 0 (smart-tuning disabled), “- - -” is displayed for <i>br</i> and setting is not possible. • When variable parameter 2 <i>PId.2</i> setting is 0 (2 degrees of freedom PID disabled), the items for <i>dP</i>, <i>dI</i>, <i>dd</i> are not displayed. • The following table shows the PID parameter set Nos. that are used for PID operation on heat/cool models when setup data <i>C44</i> setting is 1. <table border="1" data-bbox="790 1220 1380 1400"> <thead> <tr> <th>PID Set No. Designated in Program or Zone No. by PID Set Auto-switching</th> <th>PID Set (heat)</th> <th>PID Set (cool)</th> </tr> </thead> <tbody> <tr> <td>1</td> <td>2-1</td> <td>2-2</td> </tr> <tr> <td>2</td> <td>2-3</td> <td>2-4</td> </tr> <tr> <td>3</td> <td>2-5</td> <td>2-6</td> </tr> <tr> <td>4</td> <td>2-7</td> <td>2-8</td> </tr> </tbody> </table>	PID Set No. Designated in Program or Zone No. by PID Set Auto-switching	PID Set (heat)	PID Set (cool)	1	2-1	2-2	2	2-3	2-4	3	2-5	2-6	4	2-7	2-8
PID Set No. Designated in Program or Zone No. by PID Set Auto-switching	PID Set (heat)	PID Set (cool)																		
1	2-1	2-2																		
2	2-3	2-4																		
3	2-5	2-6																		
4	2-7	2-8																		
2	<i>I</i> - 21	Reset time (PID set 2-1)	0																	
3	<i>d</i> - 21	Rate time (PID set 2-1)	0																	
4	<i>oL</i> - 21	MV lower limit (PID set 2-1)	0.0																	
5	<i>oH</i> - 21	MV upper limit (PID set 2-1)	100.0																	
6	<i>rE</i> - 21	Manual reset (PID set 2-1)	50.0																	
7	<i>br</i> - 21	Brake (PID set 2-1)	0																	
8	<i>dP</i> - 21	Disturbance inhibit proportional band (PID set 2-1)	100.0																	
9	<i>dI</i> - 21	Disturbance inhibit reset time (PID set 2-1)	120																	
10	<i>dd</i> - 21	Disturbance inhibit rate time (PID set 2-1)	0																	
11	<i>P</i> - 22	Proportional band (PID set 2-2)	100.0																	
12	<i>I</i> - 22	Reset time (PID set 2-2)	0.0																	
13	<i>d</i> - 22	Rate time (PID set 2-2)	0																	
14	<i>oL</i> - 22	MV lower limit (PID set 2-2)	0.0																	
15	<i>oH</i> - 22	MV upper limit (PID set 2-2)	100.0																	
16	<i>rE</i> - 22	Manual reset (PID set 2-2)	50.0																	
17	<i>br</i> - 22	Brake (PID set 2-2)	0																	
18	<i>dP</i> - 22	Disturbance inhibit proportional band (PID set 2-2)	100.0																	
19	<i>dI</i> - 22	Disturbance inhibit reset time (PID set 2-2)	120																	
20	<i>dd</i> - 22	Disturbance inhibit rate time (PID set 2-2)	0																	
21	<i>p</i> - 23	Proportional band (PID set 2-3)	100.0																	
22	<i>I</i> - 23	Reset time (PID set 2-3)	0.0																	
23	<i>d</i> - 23	Rate time (PID set 2-3)	0																	
24	<i>oL</i> - 23	MV lower limit (PID set 2-3)	0.0																	
25	<i>oH</i> - 23	MV upper limit (PID set 2-3)	100.0																	
26	<i>rE</i> - 23	Manual reset (PID set 2-3)	50.0																	
27	<i>br</i> - 23	Brake (PID set 1-3)	0																	

No.	Item Code	Item	Factory Setting	User Setting	Setting
28	<i>dP</i> - 23	Disturbance inhibit proportional band (PID set 2-3)	100.0		<ul style="list-style-type: none"> • The MV upper and lower limits (<i>oL</i>, <i>oH</i>) function as integrating limits. When the MV reaches the upper or lower limit, integration no longer functions. This prevents reset wind-up that occurs when the PV has not risen for a long time. • Manual reset (<i>rE</i>) is a setting for eliminating offset that occurs during proportional action (integrated action disabled). For manual reset, set the MV ideal for deviation 0. • Increasing the brake (<i>br</i>) value increases the overshoot inhibit effect. However, it also lengthens the rise time.
29	<i>dI</i> - 23	Disturbance inhibit reset time (PID set 2-3)	120		
30	<i>dd</i> - 23	Disturbance inhibit rate time (PID set 2-3)	0		
31	<i>P</i> - 24	Proportional band (PID set 2-4)	100.0		
32	<i>I</i> - 24	Reset time (PID set 2-4)	0.0		
33	<i>d</i> - 24	Rate time (PID set 2-4)	0		
34	<i>oL</i> - 24	MV lower limit (PID set 2-4)	0.0		
35	<i>oH</i> - 24	MV upper limit (PID set 2-4)	100.0		
36	<i>rE</i> - 24	Manual reset (PID set 2-4)	50.0		
37	<i>br</i> - 24	Brake (PID set 2-4)	0		
38	<i>dP</i> - 24	Disturbance inhibit proportional band (PID set 2-4)	100.0		
39	<i>dI</i> - 24	Disturbance inhibit reset time (PID set 2-4)	120		
40	<i>dd</i> - 24	Disturbance inhibit rate time (PID set 2-4)	0		
41	<i>P</i> - 25	Proportional band (PID set 2-5)	100.0		
42	<i>I</i> - 25	Reset time (PID set 2-5)	0.0		
43	<i>d</i> - 25	Rate time (PID set 2-5)	0		
44	<i>oL</i> - 25	MV lower limit (PID set 2-5)	0.0		
45	<i>oH</i> - 25	MV upper limit (PID set 2-5)	100.0		
46	<i>rE</i> - 25	Manual reset (PID set 2-5)	50.0		
47	<i>br</i> - 25	Brake (PID set 2-5)	0		
48	<i>dP</i> - 25	Disturbance inhibit proportional band (PID set 2-5)	100.0		
49	<i>dI</i> - 25	Disturbance inhibit reset time (PID set 2-5)	120		
50	<i>dd</i> - 25	Disturbance inhibit rate time (PID set 2-5)	0		
51	<i>P</i> - 26	Proportional band (PID set 2-6)	100.0		
52	<i>I</i> - 26	Reset time (PID set 2-6)	0.0		
53	<i>d</i> - 26	Rate time (PID set 2-6)	0		
54	<i>oL</i> - 26	MV lower limit (PID set 2-6)	0.0		

Chapter 7. PARAMETER SETUP

No.	Item Code	Item	Factory Setting	User Setting	Setting
55	<i>oH</i> - 26	MV upper limit (PID set 2-6)	100.0		
56	<i>rE</i> - 26	Manual reset (PID set 2-6)	50.0		
57	<i>br</i> - 26	Brake (PID set 2-6)	0		
58	<i>dP</i> - 26	Disturbance inhibit proportional band (PID set 2-6)	100.0		
59	<i>dI</i> - 26	Disturbance inhibit reset time (PID set 2-6)	120		
60	<i>dd</i> - 26	Disturbance inhibit rate time (PID set 2-6)	0		
61	<i>P</i> - 27	Proportional band (PID set 2-7)	100.0		
62	<i>I</i> - 27	Reset time (PID set 2-7)	0.0		
63	<i>d</i> - 27	Rate time (PID set 2-7)	0		
64	<i>oL</i> - 27	MV lower limit (PID set 2-7)	0.0		
65	<i>oH</i> - 27	MV upper limit (PID set 2-7)	100.0		
66	<i>rE</i> - 27	Manual reset (PID set 2-7)	50.0		
67	<i>br</i> - 27	Brake (PID set 2-7)	0		
68	<i>dP</i> - 27	Disturbance inhibit proportional band (PID set 2-7)	100.0		
69	<i>dI</i> - 27	Disturbance inhibit reset time (PID set 2-7)	120		
70	<i>dd</i> - 27	Disturbance inhibit rate time (PID set 2-7)	0		
71	<i>P</i> - 28	Proportional band (PID set 2-8)	100.0		
72	<i>I</i> - 28	Reset time (PID set 2-8)	0.0		
73	<i>d</i> - 28	Rate time (PID set 2-8)	0		
74	<i>oL</i> - 28	MV lower limit (PID set 2-8)	0.0		
75	<i>oH</i> - 28	MV upper limit (PID set 2-8)	100.0		
76	<i>rE</i> - 28	Manual reset (PID set 2-8)	50.0		
77	<i>br</i> - 28	Brake (PID set 2-8)	0		
78	<i>dP</i> - 28	Disturbance inhibit proportional band (PID set 2-8)	100.0		
79	<i>dI</i> - 28	Disturbance inhibit reset time (PID set 2-8)	120		
80	<i>dd</i> - 28	Disturbance inhibit rate time (PID set 2-8)	0		

■ Setup data settings “SET”

No.	Item Code	Item	Factory Setting	User Setting	Setting
1	C01	Control action (CH1)	0		0: Reverse action (heat) 1: Direct action (cool) [Note] On heat/cool models when setup data C44 setting is 0, “- - -” is displayed and setting is not possible. On other models, external switch input can invert direct/reverse action on the setting of C01.
2	C02	Input 1 temperature unit	0		0: °C 1: °F [Note] On PV2 channel models when the input 1 range type is linear, “- - -” is displayed and setting is not possible.
3	C03	Input 1 range type	0		0 to 73 0 to 20: Thermocouple 32 to 40, 48 to 56: Resistance temperature detector 64 to 73: Linear (DC current, DC voltage) [Note] Refer to the input 1 range table. Operation according to a setting not listed in this table is not fixed.
4	C04	Input 1 range decimal point position	Not fixed		0 to 3 [Note] When the input 1 range type is non-linear, “- - -” is displayed and setting is not possible. When the input 1 range type is changed from non-linear to linear, the original non-linear range values remain.
5	C05	Input 1 range lower limit (0%)	Not fixed		-1999 to +9999U [Note] When the input 1 range type is non-linear, “- - -” is displayed and setting is not possible.
6	C06	Input 1 range upper limit (100%)	Not fixed		When the input 1 range type is changed from non-linear to linear, the original non-linear range values remain. The relationship between the analog inputs and readout values can be inverted by inverting the upper and lower limit values.
7	C07	Input 1 root extraction dropout	0.0		0.0 to 10.0% (ratio to input range) [Note] 0.0 disables square root extraction. When the input 1 range type is non-linear, “- - -” is displayed and setting is not possible.
8	C08	Input 1 linearization table approximation	0		0: Disabled 1: Enabled [Note] Table data setting (A, b) is used for the linearization table.
9	C09	SP1 lower limit	0%FS		-1999 to upper limit U [Note] Changing the input 1 range has no effect on the range. However, note that a general reset sets the range to the 0%FS value of the input 1 range.
10	C10	SP1 upper limit	100%FS		Lower limit to +9999U [Note] Changing the input 1 range has no effect on the range. However, note that a general reset sets the range to the 100%FS value of the input 1 range.
11	C11	PID set auto-switching (CH1)	0		0: OFF (PID set segment designation) 1: ON [Note] When set to 1, the PID set items in the program are invalid. The switching point for auto-switching is set in variable parameters (CP.11 to CP.17).
12	C12	MV1 setting at input 1 over-range	0		0: OFF 1: ON

Chapter 7. PARAMETER SETUP

No.	Item Code	Item	Factory Setting	User Setting	Setting
13	C13	MV1 at input 1 over-range	0		-10 to +110% [Note] When C12 setting is 0, “- - -” is displayed and setting is not possible.
14	C14	Manual change mode (MV1)	0		0: Bump-less 1: Preset [Note] When the programmer function is selected, operation is bump-less regardless of the setting of C14.
15	C15	Preset manual value (MV1)	0		-10 to +110% [Note] When C14 setting is 0, “- - -” is displayed and setting is not possible.
16	C16	MV in READY mode (MV1, MV1 heat output)	0		-10 to +110% [Note] This setting is invalid even if the programmer function is selected by C18 setting. On heat/cool models and setup data C44 setting is 0, this setting functions as the MV (heat) setting in the READY mode.
17	C17	MV (cool) in READY mode (MV1 cool output)	0		-10 to +110% [Note] When the model is not a heat/cool model, and setup data C44 is set to 1 on a heat/cool model, “- - -” is displayed and setting is not possible.
18	C18	Main output type (CH1)	0		0: MV1 output (controller function) 1: SP1 output (programmer function) [Note] “- - -” is displayed and setting is not possible in the following instances: • 0D output: C44 setting is 1 and C76 setting is 0 • 5G output: C44 setting is 0 and C77 setting is 0 C44 setting is 1 and C76 setting is 0 • 2G/3D/5K: C44 setting is 1 and C77 setting is 0
19	C19	SP1 main output lower limit (4 mA setting)	0U		-1999 to +9999U [Note] When C11 setting is 1 or 0, “- - -” is displayed and setting is not possible.
20	C20	SP1 main output upper limit (20 mA setting)	1000U		The relationship between the analog outputs and SP1 can be inverted by inverting the upper and lower limit values.
21	C21	Control action (CH2)	0		0: Reverse action (heat, humidifying) 1: Direct action (cool, dehumidifying) [Note] On heat/cool models and setup data C44 setting is 1 “- - -” is displayed and setting is not possible. On other models, external switch input can invert direct/reverse action on the setting of C21.
22	C22	Input 2 temperature unit	0		0: °C 1: °F [Note] On PV2 channel models, when the input 2 range type is linear, “- - -” is displayed and setting is not possible.
23	C23	Input 2 range type	128		128 to 193 128, 129: Thermocouple 160, 161, 176, 177: Resistance temperature detector 192, 193: Linear (DC current, DC voltage) [Note] Refer to the input 2 range table. Operation according to a setting not listed in this table is not fixed.
24	C24	Input 2 range decimal point position	Not fixed		0 to 3 [Note] When the input 2 range type is non-linear, “- - -” is displayed and setting is not possible. When the input 2 range type is changed from non-linear to linear, the original non-linear range values remain.

No.	Item Code	Item	Factory Setting	User Setting	Setting
25	C25	Input 2 range lower limit (0%)	Not fixed		-1999 to +9999U [Note] When the input 2 range type is non-linear, “- - -” is displayed and setting is not possible.
26	C26	Input 2 range upper limit (100%)	Not fixed		When the input 2 range type is changed from non-linear to linear, the original non-linear range values remain. The relationship between the analog inputs and readout values can be inverted by inverting the upper and lower limit values.
27	C27	Input 2 root extraction dropout	0.0		0.0 to 10.0% (ratio to input range) [Note] 0.0 disables square root extraction. When the input 2 range type is non-linear, “- - -” is displayed and setting is not possible.
28	C28	Input 2 linearization table approximation	0		0: Disabled 1: Enabled [Note] Table data setting (C, d) is used for the linearization table.
29	C29	Unused	—		[Note]
30	C30	Unused	—		“- - -” is displayed and setting is not possible.
31	C31	Unused	—		
32	C32	SP2 lower limit	0%FS 0.0		-1999 to upper limit U (PV2 channel model) 0.0 to upper %RH (temperature/humidity operation model) [Note] Changing the input 2 range has no effect on the range. However, note that when a general reset is carried out, the value becomes the 0%FS value of the input 2 range on PV2 channel models, and 0.0%RH on temperature/humidity operation models.
33	C33	SP2 upper limit	100%FS 100.0		Lower limit to 9999U (PV2 channel model) Lower limit to 100.0%RH (temperature/humidity operation model) [Note] Changing the input 2 range has no effect on the range. However, note that when a general reset is carried out, the value becomes the 100%FS value of the input 2 range on PV2 channel models, and 100.0%RH on temperature/humidity operation models.
34	C34	PID set auto-switching (CH2)	0		0: OFF (PID set segment designation on CH2 side) 1: ON [Note] When set to 1, the CH2 side PID set item in the program is invalid. The switching point for auto-switching is set in variable parameters (CP.21 to CP.27).
35	C35	PV2 setting at input 2 over-range (MV2)	0		0: OFF 1: ON [Note] On temperature/humidity operation models, “- - -” is displayed and setting is not possible.
36	C36	PV2 at input 2 over-range (MV2)	0		-10 to +110% [Note] On PV2 channel models, when C35 setting is 0, “- - -” is displayed and setting is not possible.
37	C37	Manual change mode (MV2)	0		0: Bump-less 1: Preset [Note] When the programmer function is selected, operation is bump-less regardless of the setting of C37.
38	C38	Preset manual value (MV2)	0		-10 to +110% [Note] When C37 setting is 0, “- - -” is displayed and setting is not possible. -10 to +110%
39	C39	MV in READY mode (MV2, MV2 heat output)	0		[Note] This setting is invalid even if the DCP32 is selected for use as a programmer with C41 setting at 1. On heat/cool modes, when C44 setting is 1, the setting functions as the MV (heat) setting in the READY mode.

Chapter 7. PARAMETER SETUP

No.	Item Code	Item	Factory Setting	User Setting	Setting
40	C40	MV (cool) in READY mode (MV2 cool output)	0		-10 to +110% [Note] When the model is not a heat/cool model, and setup data C44 is set to 0 on a heat/cool model, " - - - " is displayed and setting is not possible. Input 2 channel model
41	C41	Main output type (CH2)	0		0: MV2 output (controller function) 1: SP2 output (programmer function) 2: SP2 output (programmer function) Temperature/humidity operation model 0: MV2 output (controller function) 1: SP2 output (programmer function) 2: SPw output (SPw programmer function) [Note] " - - - " is displayed and setting is not possible in the following instances: • 0D output: C44 setting is 0 and C76 setting is 0 • 5G output: C44 setting is 1 and C75 setting is 0 C44 setting is 0 and C76 setting is 0 • 2G/3D/5K output: C44 setting is 0 and C77 setting is 0 On input 2 channel models, settings 1 and 2 mean the same.
42	C42	SP2 main output lower limit (4 mA)	0U		-1999 to +9999U [Note] When C41 setting is " - - - " or 0, " - - - " is displayed and setting is not possible.
43	C43	SP2 main output upper limit (20 mA)	1000U		The relationship between the analog outputs and SP2 and SPw can be inverted by inverting the upper and lower limit values.
44	C44	MV1/2 switching	0		0: MV1/2 switching OFF 1: MV1/2 switching ON [Note] • On heat/cool and non-2G output models When set to 0, MV1 is switched to output 1, and MV2 is switched to output 2. When set to 1, MV1 is switched to output 2, and MV2 is switched to output 1. • On heat/cool and 2G output models When set to 0, MV1 is switched to output 1 + output 2, and MV2 is switched to output 3. When set to 1, MV1 is switched to output 3, and MV2 is switched to output 1 + output 2.
45	C45	3-position control	0		0: 3-position control disabled 1: 3-position control enabled [Note] On models not supporting 3D output, " - - - " is displayed and setting is not possible.
46	C46	Unused	—		[Note] " - - - " is displayed and setting is not possible.
47	C57	Unused	—		
48	C48	Unused	—		
49	C49	Auxiliary output type	0		0: PV1 1: SP1 2: Deviation 1 3: MV1 4: PV2 5: SP2 6: Deviation 2 7: MV2 8: MFB 9: PVw 10: SPw 11: NOP [Note] When auxiliary output is not supported, " - - - " is displayed and setting is not possible. Output is fixed to 4 mA or 0 mA in the following instances: • When set to NOP • When set to MFB on non-2G output models • When set to PVw and SPw on input 2 channel models • When set to SP or deviation and output is in the READY mode

No.	Item Code	Item	Factory Setting	User Setting	Setting
50	C50	Auxiliary output lower limit (4 mA)	0		-1999 to +9999U -1999 to +999.9% [Note]
51	C51	Auxiliary output upper limit (20 mA)	1000		When auxiliary output is not supported, “- - -” is displayed and setting is not possible. When the auxiliary output type is MV or MFB, the unit is %. Otherwise, the unit is U.
52	C52	External switch input RSW5 assignment	0		0: NOP 1: Fast operation
53	C53	External switch input RSW6 assignment	0		2: PV start (CH1) 3: NOP
54	C54	External switch input RSW7 assignment	0		4: ST start/stop (CH1) 5: NOP 6: Auto/manual (CH1) 7: Cancel G.Soak by OR conditions 8: Cancel G.Soak by AND conditions 9: Direct/reverse action inversion (CH1) 10: NOP 11: NOP 12: PV start (CH2) 13: NOP 14: AT start/stop (CH2) 15: NOP 16: Auto/manual (CH2) 17: NOP 18: NOP 19: Direct/reverse action inversion (CH2) 20: NOP [Note] On external switch 4-input models, “- - -” is displayed and setting is not displayed. When the same assignment is set to two or more RSWs, the RSW setting with the lowest No. is valid. When this setting is set to NOP, the controller state is not switched by external switch input ON/OFF. The controller state can be switched ON/OFF by communications.
55	C55	PARA key assignment item 1	1000		1000 to 5000 [Note]
56	C56	PARA key assignment item 2	1000		To set the No., add the No. of the item to be assigned to PARA key to the following values for the setting group containing that item. • 1000: Constant-value operation data • 1500: PID parameter 1 • 2000: PID parameter 2 • 2500: Variable parameter • 3000: Variable parameter 2 • 3500: Event configuration data • 4000: Table data • 4500: Setup data Assignments to which a nonexistent No. have been set are invalid.
57	C57	PARA key assignment item 3	1000		
58	C58	PARA key assignment item 4	1000		
59	C59	PARA key assignment item 5	1000		
60	C60	PARA key assignment item 6	1000		
61	C61	PARA key assignment item 7	1000		
62	C62	PARA key assignment item 8	1000		
63	C63	Operation completion state	0		
64	C64	Program time unit	0		0: Hours/minutes 1: Minutes/seconds
65	C65	Time display	0		0: Remaining segment time 1: Total operation time [Note] The total operation time returns to 0 in the READY mode.
66	C66	PV display	0		0: ON 1: PV1 OFF 2: PV2 OFF 3: PV1, PV2 OFF

Chapter 7. PARAMETER SETUP

No.	Item Code	Item	Factory Setting	User Setting	Setting
67	C67	Alarm display	0		0: Display ON 1: Display OFF [Note] Even when set to 1, alarm-related events do not operate.
68	C68	Programming item: Events 1 to 3	0		0: Display ON 1: Display OFF
69	C69	Programming item: Time events 1 to 5	0		[Note] Even if each of the items are set to 1, the function operates if data is set to the program.
70	C70	Programming item: PID set, G.Soak	0		On models not supporting time events, time event items are not displayed in program settings regardless of the number of C69 settings.
71	C71	Programming item: PV start, cycle, pattern link	0		
72	C72	Cold junction compensation	0		0: Compensated internally 1: Compensated externally [Note] When both input 1 range type and input 2 range type are other than a thermocouple, " - - - " is displayed and setting is not possible.
73	C73	Input operation at input 1 disconnection	0		0: Upscale 1: Downscale [Note] This setting is valid when the input 1 range type is thermocouple, resistance temperature detector or linear (mV series).
74	C74	Voltage time-proportional output system	0		0: Input ON again enabled within time-proportional cycle 1: Input ON again disabled within time-proportional cycle [Note] When any of outputs 1, 2 or 3 are not voltage time-proportional outputs, " - - - " is displayed and setting is not possible.
75	C75	Output 1 selection	0		0: Current output 1: Voltage output
76	C76	Output 2 selection	0		[Note]
77	C77	Output 3 selection	0		When each of the outputs are relay output, position-proportional output, auxiliary output or output is not mounted, " - - - " is displayed and setting is not possible.
78	C78	Voltage output 1 adjustment	15		2 to 22 mA [Note]
79	C79	Voltage output 2 adjustment	15		When each of the outputs are other than voltage output (including heat/cool), " - - - " is displayed and setting is not possible.
80	C80	Voltage output 3 adjustment	15		Normally, use the factory setting.
81	C80	Input 1 burnout current (Expansion setting 1)	0		0: Burnout current ON 1: Burnout current OFF [Note] Normally set to "0". When radiamatic temperature detector RT50 is connected to input 1, use at setting 1.
82	C82	Expansion setting 2	0		0: Expansion disabled 1: Expansion enabled [Note] This setting is for service use only. Normally set to 0.
83	C83	Unused	—		[Note] " - - - " is displayed and setting is not possible.
84	C84	CPL communications address	0		0 to 127 [Note] On models not supporting communications, or when steup data C97 setting is not 0, " - - - " is displayed and setting is not possible. 0 disables communications.

No.	Item Code	Item	Factory Setting	User Setting	Setting
85	C85	CPL communications speed/code	0		0: 9600 bps/even parity, 1 stop bit 1: 4800 bps/no parity, 2 stop bits 2: 2400 bps/even parity, 1 stop bit 3: 1200 bps/no parity, 2 stop bits [Note] On models not supporting communications, “- - -” is displayed and setting is not possible.
86	C86	Unused	—		[Note] “- - -” is displayed and setting is not possible.
87	C87	Unused	—		
88	C88	Unused	—		
89	C89	Unused	—		
90	C90	Special functions	0		[Note] Normally set to “0”.
91	C91	Input 1 Zener barrier adjustment	—		[Note] “- - -” is displayed and setting is not possible.
92	C92	Input 2 Zener barrier adjustment	—		
93	C93	CPL communications port selection	0		0: Add-on terminal 1 to 15: Loader jack (communications address)
94	C94	Unused	—		[Note] “- - -” is displayed and setting is not possible.
95	C95	Unused	—		
96	C96	Hardware type 1	0		[Note] These settings are for service use only, and can only be verified.
97	C97	Hardware type 2	0		
98	C98	ROM ID			
99	C99	ROM item			
100	C00	ROM revision			

■ Description of setup data

- **C07 (input 1 square root extraction dropout)**
- **C27 (input 2 square root extraction dropout)**

- Generally, the differential pressure detected by an orifice on a differential pressure type flowmeter, is proportional to the square of the flowrate signal. For this reason, square root extraction is carried out when uniform signals are required.

When input for square root extraction is the dropout value set by *C07* or *C27* or less, output from square root extraction processing can be set to 0%.

- When *C07* or *C27* is set to 0.0, square root extraction is not carried out.
- Square root extraction is carried out within the range 0 to 100% of input. In the ranges -10.0 to 0.0% or 100.0 to 110.0% of input, normal scaling is carried out.

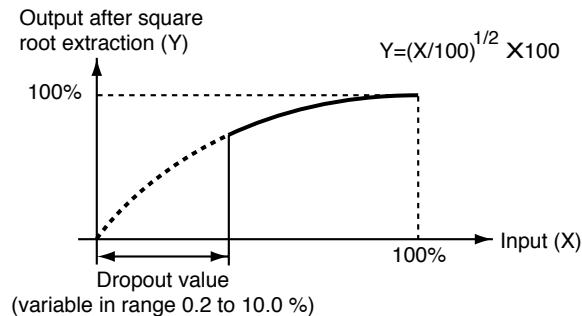

- **C09 (SP1 lower limit)**
- **C10 (SP1 upper limit)**
- **C32 (SP2 lower limit)**
- **C33 (SP2 upper limit)**

- This is a program setup pattern item, and functions as a limiter when setting or changing SP.
- In the program operation mode, this functions as a limiter on the value obtained by adding the SP set to the program to the SP bias (variable parameter). The result of this operation is taken as SP.
- This functions as a limiter when setting or changing the SP in constant-value data setup.
- In the constant-value operation mode, this functions as a limiter on the value obtained by adding the SP set to the constant-value operation data to the SP bias (variable parameter). The result of this operation is taken as SP.

- **C50 (auxiliary output lower limit)**

- **C51 (auxiliary output upper limit)**

- This parameter is the scaling setting for auxiliary output. The values of the upper limit setting and lower limit setting can also be inverted.
- In the following example, the type is set to MV at auxiliary input. 12 mA is output when MV is 100% and 20 mA is output when MV is 0%. In the following figure, MV is 200% when virtually calculated at 4 mA. Accordingly, the settings of C50 and C51 become 200.0 and 0.0, respectively.

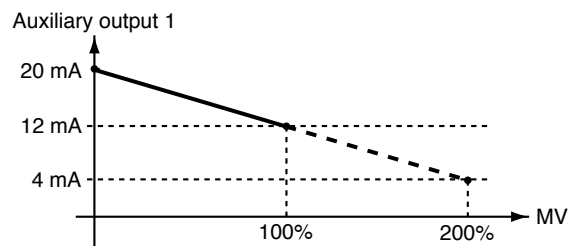

- **C65 (time display)**

0: Remaining segment time

1: Total operation time

- This parameter selects the time display in the basic display state in the program operation mode.
- When set to 0, in the READY mode, the time setting value of the currently selected segment is displayed.
- When set to 0, in the RUN, HOLD, FAST or END modes, the remaining time for the currently executing segment is displayed after being rounded down. For example, if the remaining time is 1 hour, 30 minutes, 59 seconds when the time unit is set to "hours:minutes", the time display is "1 .30".
- When set to 1, in the READY mode, the time display is "0 .00".
- When set to 1, in the RUN, HOLD, FAST or END modes, the time it takes to move from the READY to the RUN mode is displayed after being round down. After "99.59" the time display changes to "0 .00". For example, if the remaining time is 101 hours, 30 minutes, 59 seconds when the total operation time is set to "hours:minutes", the time display is "1 .30".
- In the FAST mode, the time display changes according to the FAST scale if this parameter is set to either 0 or 1.

- **C66 (PV display)**

This parameter selects PV display in the basic display state. You can select between numerical display or no display at all. The setting of this parameter does not influence PV-related input processing, PID operation, event output, auxiliary output and alarm display.

Also, to eliminate PV alarm display or PV alarm event output, select the thermocouple range by the input range to short-circuit the input terminals.

● **C72 (cold junction compensation)**

- 0: Compensated internally
- 1: Compensated externally

- This selects how thermocouple cold junctions are to be compensated.
- When set to 1, carry out 0°C compensation by an ice box, for example.

● **C74 (voltage time-proportional output system)**

- 0: Input ON again enabled within time-proportional cycle
- 1: Input ON again disabled within time-proportional cycle

- This selects whether or not to turn output ON again even if output is OFF when the results of PID operation have changed during the time-proportional cycle (cycle time).
- The figure below shows each of these differences.

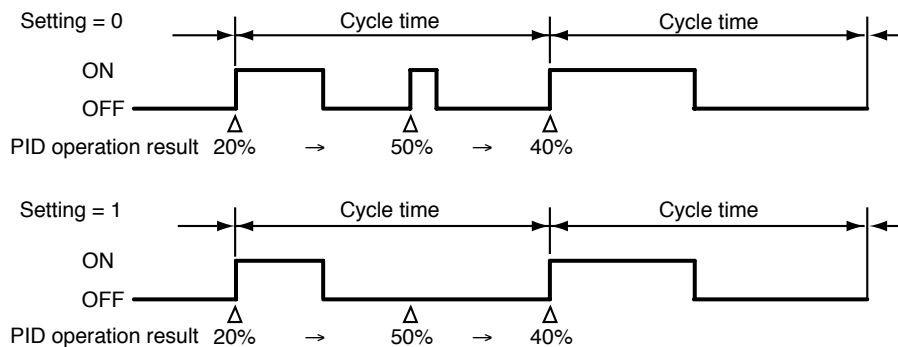

● **C78 (voltage output 1 adjustment)**

● **C79 (voltage output 2 adjustment)**

● **C80 (voltage output 3 adjustment)**

When driving an SSR by voltage time-proportional output, the output voltage of the DCP302 must be within the input rated voltage (optimum ignition voltage) of the SSR.

On the DCP302, a newly developed variable output system is utilized that enables output of the optimum ignition voltage even when driving two or more SSRs.

This system sets and outputs the optimum current value on the DCP302 so that the optimum ignition voltage with respect to the internal impedance of the SSR side can be obtained.

The following shows equivalent circuits and related formulas.

• Description of Symbols

① Details

- I_0 : Setting output current of the DCP302 (setting range: 2 to 22 mA)
- V_0 : Max. load discharge voltage (approx. 13.2 V)
- $V_{SSR'}$: Actual input voltage to SSR
- V_{SSR} : Input rated voltage range of SSR ($V_{SSR/MIN}$ to $V_{SSR/MAX}$)
- $V_{SSR/MIN}$: Minimum input rated voltage of SSR
- $V_{SSR/MAX}$: Maximum input rated voltage of SSR
- Z : Internal impedance of SSR
- V_D : Internal voltage drop of SSR (normally about 1 to 2 V)

② Equivalent circuit when one SSR is connected

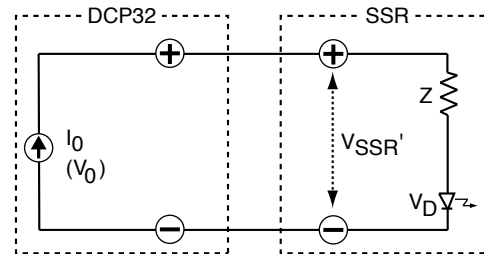

Formulas (1) and (2) must be satisfied.

$$V_{SSR/MIN} \leq I_0 \times Z + V_D \leq V_0 \text{ ---(1)}$$

$$V_{SSR'} \leq V_{SSR/MAX} \text{ ---(2)}$$

$$(V_{SSR'} = I_0 \times Z + V_D)$$

③ Equivalent circuit when N number of SSRs are connected in series

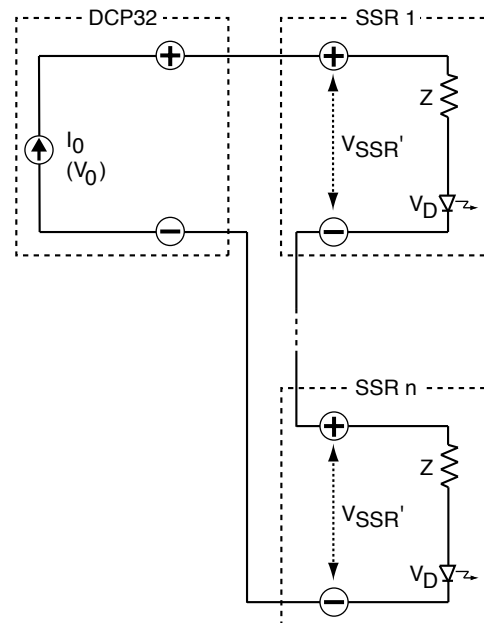

Formulas (3) and (4) must be satisfied.

$$V_{SSR/MIN} \leq I_0 \times Z + V_D \leq V_0/N \text{ ---(3)}$$

$$V_{SSR'} \leq V_{SSR/MAX} \text{ ---(4)}$$

$$(V_{SSR'} = I_0 \times Z + V_D)$$

④ Equivalent circuit when N number of SSRs are connected in parallel

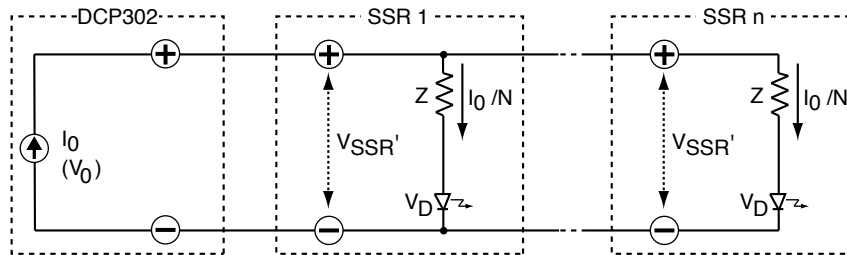

Formulas (5) and (6) must be satisfied.

$$V_{SSR/MIN} \leq I_0/N \times Z + V_D \leq V_0 \quad \text{---(5)}$$

$$V_{SSR}' \leq V_{SSR/MAX} \quad \text{---(6)}$$

$$(V_{SSR}' = I_0/N \times Z + V_D)$$

⑤ Example: Using Yamatake Corporation's PGM

V_{SSR} : 3 to 6 V

Z : 260 $\Omega \pm 5\%$

V_D : 0.8 to 1.3 V

- What value should I_0 be set to when connecting one PGM?

As shown in the figure on the right, a fixed-current system is used for the voltage output of the DCP302. The fixed current can be calculated as follows from the input voltage range of PGM.

$$8.9 \text{ mA} \leq I \leq 17.2 \text{ mA}$$

$$I_{MIN} \times Z_{MIN} + V_{D/MIN} > 3$$

$$I_{MIN} > 8.9 \text{ mA}$$

$$I_{MAX} \times Z_{MAX} + V_{D/MAX} < 6$$

$$I_{MAX} < 17.2 \text{ mA}$$

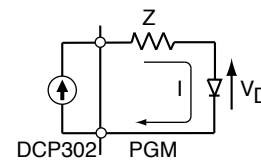

- How many PGMs can be connected?

A current of 8.9 mA or more must flow to a single PGM. On the other hand, the maximum current of the DCP302 is 22 mA. Accordingly, two PGMs can be connected in parallel.

In the case of a series connection, due to the maximum output current (22 mA) and allowable load resistance (600 Ω), the maximum voltage that can be applied to a load becomes 13.2 V (22 mA x 600 Ω).

When a current of 8.9 mA flows to a PGM, the maximum voltage at both of its input terminals becomes 3.7 V.

$$0.0089 \times 260 \times 1.05 + 1.3 = 3.7 \text{ V}$$

Accordingly, $13.2 \div 3.7 = 3.56$, which means that three PGMs can be connected in series.

The above calculation assumes operation in the worst conditions. For example, even if four PGMs are connected in series, they should operate normally if a voltage of 3 V or more is applied to each of the PGMs in a voltage ON state.

● C90 (special function)

- Normally, set to “0”.
- When set to 102, the control output range 0 to 100% becomes 0 to 20 mA when current output (including heat/cool output) is set as the output. However, note that when control output is less than 0%, current output is 0 mA, and when control output is less than 5%, the accuracy is $\pm 0.5\%$.
- When set to 103, the control output range 0 to 100% becomes 0 to 20 mA when current output (including heat/cool output) and auxiliary output is set as the output. However, note that when control output is less than 0%, current output is 0 mA, and when control output is less than 5%, the accuracy is $\pm 0.5\%$.
- When set to 241, Zener barrier adjustment (C91) is displayed when the input 1 range type (C03) is an RTD.
- When set to 241, Zener barrier adjustment (C92) is displayed when the input 2 range type (C23) is an RTD.

● C91 (input 1 Zener barrier adjustment)

● C92 (input 2 Zener barrier adjustment)

The following adjustment must be made when using a Zener barrier.

- ① Turn the DCP302 OFF. When you have finished mounting and wiring the DCP302, short-circuit across the A and B terminals of the RTD.

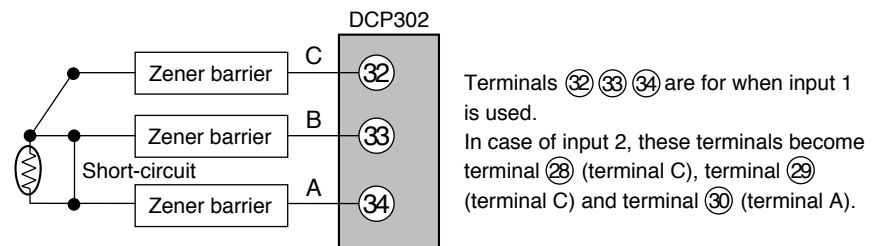

- ② Turn the DCP302 ON again, and set setup data C90 setting to 241. For details on how to change settings, see “7-1 Parameter Setup” (page 7-1).
- ③ Display the setup data C91 or C92 setting.
- ④ Press the ENT key to display the difference (A-B) between the resistances of the Zener barriers connected to leads A and B on the lower display.
- ⑤ Press the ENT key to memorize the difference (A-B) between the resistances on the DCP302.
- ⑥ Press the DISP key to set the DCP302 to the basic display state.
- ⑦ Turn the power OFF, and remove the short-circuit across A and B.

! Handling Precautions

- The resistance error of the Zener barrier connected to leads A and B cannot be adjusted unless it is 20 Ω or less.
- This adjustment is not required when a Zener barrier and an input other than an RTD are not used.
- Once the Zener barrier has been adjusted, compensation is carried out on the Zener barrier. When using an RTD without a Zener barrier, re-adjust without the Zener barrier.

● **C93 (CPL communications port selection)**

- When set to 0, CPL communications from the loader jack is not possible. In this case, CPL communications is possible from the addon terminal under setup *C84* and *C85* communications conditions if the controller model supports CPL communications.
- When set to 1 to 15, CPL communications from the loader jack is not possible, and the *C93* setting becomes the CPL communications address. Communications conditions are also 4800bps, even parity and 1 stop bit. In this case, CPL communications is not possible from the addon terminal even if the controller model supports CPL communications.
- Use the special cable to connect the RS-232C port on the personal computer and the loader jack on the equipment.
- When the setup *C00* (ROM revision) setting indication is 0 or 1, the setup *C93* setting indication cannot be set at "---".

Also, communications from the loader jack is not possible.

■ Table data settings “tbl”

No.	Item Code	Item	Factory Setting	User Setting	Setting
1	t-A.1	Input linearization table approximation A1	0U		-1999 to +9999U [Note] For input 1 When setup data C08 setting is 0, “- - -” is displayed and setting is not possible. Item An indicates input (X-axis) and B _n indicates output (Y-axis). In principle, set so that A1 is ≤ A2, A2 ≤ A3 and so forth up to A10 ≤ A11. Linear interpolation is carried out between points on the linearization table. The ends of the linearization table are fixed to (A0, B0) = (-2000, -2000) and (A12, B12) = (10000, 10000). When A _n ≤ X ≤ A _{n+1} , Y becomes (X-A _n) × (B _{n+1} -B _n)/(A _{n+1} -A _n) + B _n .
2	t-A.2	Input linearization table approximation A2	1000U		
3	t-A.3	Input linearization table approximation A3	1000U		
4	t-A.4	Input linearization table approximation A4	1000U		
5	t-A.5	Input linearization table approximation A5	1000U		
6	t-A.6	Input linearization table approximation A6	1000U		
7	t-A.7	Input linearization table approximation A7	1000U		
8	t-A.8	Input linearization table approximation A8	1000U		
9	t-A.9	Input linearization table approximation A9	1000U		
10	t-A.A	Input linearization table approximation A10	1000U		
11	t-A.b	Input linearization table approximation A11	1000U		
12	t-b.1	Input linearization table approximation B1	0U		
13	t-b.2	Input linearization table approximation B2	1000U		
14	t-b.3	Input linearization table approximation B3	1000U		
15	t-b.4	Input linearization table approximation B4	1000U		
16	t-b.5	Input linearization table approximation B5	1000U		
17	t-b.6	Input linearization table approximation B6	1000U		
18	t-b.7	Input linearization table approximation B7	1000U		
19	t-b.8	Input linearization table approximation B8	1000U		
20	t-b.9	Input linearization table approximation B9	1000U		
21	t-b.A	Input linearization table approximation B10	1000U		
22	t-b.b	Input linearization table approximation B11	1000U		
23	t-C.1	Input linearization table approximation C1	0U		-1999 to +9999U [Note] For input 2 When setup data C28 setting is 0, “- - -” is displayed and setting is not possible. Item Cn indicates input (X-axis) and D _n indicates output (Y-axis). In principle, set so that C1 is ≤ C2, C2 ≤ C3 and so forth up to C10 ≤ C11. Linear interpolation is carried out between points on the linearization table. The ends of the linearization table are fixed to (C0, D0) = (-2000, -2000) and (C12, D12) = (10000, 10000). When C _n ≤ X ≤ C _{n+1} , Y becomes (X-C _n) × (D _{n+1} -D _n)/(C _{n+1} -C _n) + D _n .
24	t-C.2	Input linearization table approximation C2	1000U		
25	t-C.3	Input linearization table approximation C3	1000U		
26	t-C.4	Input linearization table approximation C4	1000U		
27	t-C.5	Input linearization table approximation C5	1000U		
28	t-C.6	Input linearization table approximation C6	1000U		
29	t-C.7	Input linearization table approximation C7	1000U		
30	t-C.8	Input linearization table approximation C8	1000U		
31	t-C.9	Input linearization table approximation C9	1000U		
32	t-C.A	Input linearization table approximation C10	1000U		
33	t-d.b	Input linearization table approximation C11	1000U		
34	t-d.1	Input linearization table approximation D1	0U		
35	t-d.2	Input linearization table approximation D2	1000U		
36	t-d.3	Input linearization table approximation D3	1000U		
37	t-d.4	Input linearization table approximation D4	1000U		
38	t-d.5	Input linearization table approximation D5	1000U		
39	t-d.6	Input linearization table approximation D6	1000U		
40	t-d.7	Input linearization table approximation D7	1000U		
41	t-d.8	Input linearization table approximation D8	1000U		
42	t-d.9	Input linearization table approximation D9	1000U		
43	t-d.A	Input linearization table approximation D10	1000U		
44	t-d.b	Input linearization table approximation D11	1000U		

■ Description of table data settings

- *t-A.1* to *t-A.b*
- *t-b.1* to *t-b.b*

- These settings are for the A-axis (input) and B-axis (output) settings of input 1 linearization table approximation.
- Both ends of the linearization table are fixed at -2000U, -2000U and 10000U,10000U. The linearization table is formed by connecting 11 points of table data settings between the two ends.
- Table data is set not by percentages but directly by engineering unit. When the range type is set to linear, set scaled values.

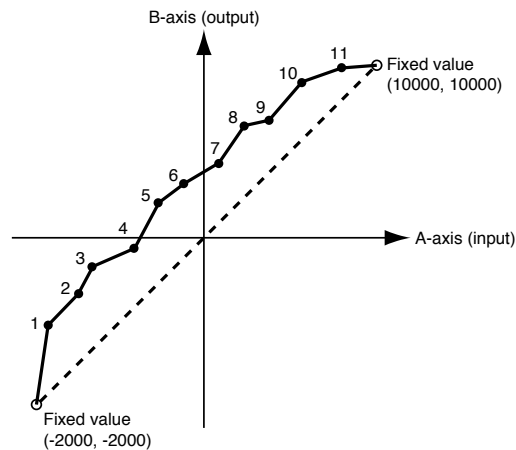

- Points on the broken-line, A_n and B_n , must be set so that they increase in the following way $(A_1, B_1) = (0, 0)$, $(A_2, B_2) = (100, 100)$ and so forth. If set points break this relationship, the point in conflict must be excluded to create the linearization table.

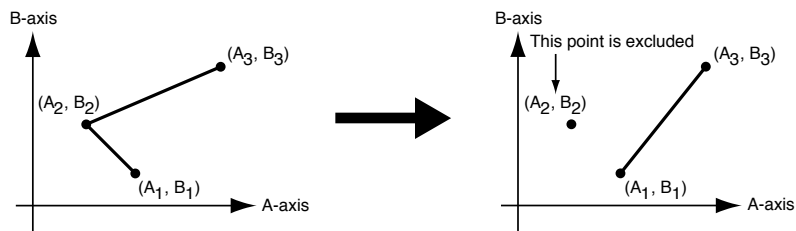

- When two equal points such as A_1 and A_2 are set for the A-axis, B_1 shall be taken as the output value.

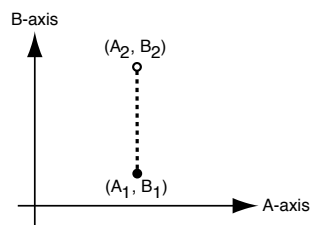

- *t-C.1-* to *t-C.b*
- *t-d.1-* to *t-d.b*

- These settings are for the C-axis (input) and D-axis (output) settings of input 2 linearization table approximation.
- In the above figures, the functions of the A-and B-axes are transferred to the C- and D-axes.

■ Constant-value operation data settings “CnSt”

No.	Item Code	Item	Factory Setting	User Setting	Setting
1	<i>modE</i>	Operation mode	0		0: Program operation 1: Constant-value operation [Note] This setting can be changed only in the READY mode.
2	<i>SP</i>	SP1	0		This setting can be set in the SP1 lower to upper limit range in setup data settings <i>C09</i> and <i>C10</i> .
3	<i>SP2</i>	SP2	0		This setting can be set in the SP2 lower to upper limit range in setup data settings <i>C32</i> and <i>C33</i> .
4	<i>Ev1</i>	Event 1 setting value	9999		-1999 to +9999U (event type is PV, deviation or SP)
5	<i>Ev2</i>	Event 2 setting value	9999		0 to 9999U (event type is absolute value deviation)
6	<i>Ev3</i>	Event 3 setting value	9999		-10.0 to +110.0% (event type is MV or MFB) [Note] When the event configuration data type setting is ≥ 50 for each event, “- - -” is displayed and setting is not possible.
7	—	Unused	—		[Note]
8	—	Unused	—		“- - -” is displayed and setting is not possible.
9	—	Unused	—		
10	—	Unused	—		
11	<i>P.</i>	Proportional band (CH1)	100.0		<i>P.</i> : 0.1 to 999.9%
12	<i>I.</i>	Reset time (CH1)	0		<i>I.</i> : 0 to 3600 seconds. 0 disables integral action.
13	<i>d.</i>	Rate time (CH1)	0		<i>d.</i> : 0 to 1200 seconds. 0 disables derivative action.
14	<i>oL.</i>	MV lower limit (CH1)	0.0		<i>oL.</i> : -10.0 to MV upper limit %
15	<i>oH.</i>	MV upper limit (CH1)	0.0		<i>oH.</i> : MV lower limit to +110.0%
16	<i>rE.</i>	Manual reset (CH1)	50.0		<i>rE.</i> : 0.0 to 100.0%
17	<i>br.</i>	Brake (CH1)	0		<i>br.</i> : 0 to 30 0 disables the brake function.
18	<i>dP.</i>	Disturbance inhibit proportional band (CH1)	100.0		<i>dP.</i> : 0.1 to 999.9%
19	<i>dl.</i>	Disturbance inhibit reset time (CH1)	120		<i>dl.</i> : 1 to 3600 seconds <i>dd.</i> : 0 to 1200 seconds [Note]
20	<i>dd.</i>	Disturbance inhibit rate time (CH1)	0		• These parameters are used for control of CH1. • When CH1 is used primarily for SP (setup data <i>C18</i> setting is 1), “- - -” is displayed and setting is not possible.
21	<i>P.-C</i>	Proportional band (for CH1 cool control)	100.0		• When variable parameter <i>m-C</i> setting is 2 (estimated position control only) on 2G output models and setup data <i>C44</i> setting is 0, “- - -” is displayed for items <i>oL.</i> and <i>oH.</i> , and setting is not possible.
22	<i>I.-C</i>	Reset time (for CH1 cool control)	0		• When <i>I</i> setting is not 0, “- - -” is displayed for <i>rE.</i> and setting is not possible.
23	<i>d.-C</i>	Rate time (for CH1 cool control)	0		• When variable parameter <i>St</i> setting is 0 (smart-tuning disabled), “- - -” is displayed for <i>br.</i> and setting is not possible.
24	<i>oL.-C</i>	MV lower limit (for CH1 cool control)	0.0		• When variable parameter <i>2PId</i> setting is 0 (2 degrees of freedom PID disabled), “- - -” is displayed for <i>dP.</i> , <i>dl.</i> , <i>dd.</i> and setting is not possible.
25	<i>oH.-C</i>	MV upper limit (for CH1 cool control)	100.0		• “- - -” is displayed and setting is not possible for the <i>P.-C</i> to <i>rE.-C</i> items in the following instances: - On models other than heat/cool models - On heat/cool models and setup data <i>C44</i> is set to 1 - On 3D output models and setup data <i>C45</i> is set to 1
26	<i>rE.-C</i>	Manual reset (for CH1 cool control)	50.0		For details, see the Note for PID parameters.
27	—	Unused	—		[Note]
28	—	Unused	—		“- - -” is displayed and setting is not possible.
29	—	Unused	—		
30	—	Unused	—		

Chapter 7. PARAMETER SETUP

No.	Item Code	Item	Factory Setting	User Setting	Setting
31	<i>P.-2</i>	Proportional band (CH2)	100.0		<i>P.</i> : 0.1 to 999.9% <i>I.</i> : 0 to 3600 seconds. 0 disables integral action. <i>d.</i> : 0 to 1200 seconds. 0 disables derivative action. <i>oL.</i> : -10.0 to MV upper limit % <i>oH.</i> : MV lower limit % to +110.0% <i>rE.</i> : 0.0 to 100.0% <i>br.</i> : 0 to 30 0 disables the brake function. <i>dP.</i> : 0.1 to 999.9% <i>dI.</i> : 1 to 3600 seconds <i>dd.</i> : 0 to 1200 seconds [Note] • These parameters are used for control of CH2. • When CH2 is used primarily for SP (setup data <i>C41</i> setting is 1), “- - -” is displayed and setting is not possible. • When variable parameter <i>m-C</i> setting is 2 (estimated position control only) on 2G output models and setup data <i>C44</i> setting is 1, “- - -” is displayed for items <i>oL.</i> and <i>oH.</i> , and setting is not possible. • When <i>I</i> setting is not 0, “- - -” is displayed for <i>rE.</i> and setting is not possible. • When variable parameter 2 <i>St.2</i> setting is 0 (smart-tuning disabled), “- - -” is displayed for <i>br.</i> and setting is not possible. • When variable parameter 2 <i>PI.d.2</i> setting is 0 (2 degrees of freedom PID disabled), “- - -” is displayed for <i>dP.</i> , <i>dI.</i> , <i>dd.</i> and setting is not possible. • “- - -” is displayed and setting is not possible for the <i>P.-2C</i> to <i>rE.-2C</i> items in the following instances: - On models other than heat/cool models - On heat/cool models and setup data <i>C44</i> is set to 0 - On 3D output models and setup data <i>C45</i> is set to 1 For details, see the Note for PID parameters.
32	<i>I.-2</i>	Reset time (CH2)	0.		
33	<i>d.-2</i>	Rate time (CH2)	0.		
34	<i>oL.-2</i>	MV lower limit (CH2)	0.0		
35	<i>oH.-2</i>	MV upper limit (CH2)	100.0		
36	<i>rE.-2</i>	Manual reset (CH2)	50.0		
37	<i>br.-2</i>	Brake (CH2)	0		
38	<i>dP.-2</i>	Disturbance inhibit proportional band (CH2)	100.0		
39	<i>dI.-2</i>	Disturbance inhibit reset time (CH2)	120		
40	<i>dd.-2</i>	Disturbance inhibit rate time (CH2)	0		
41	<i>P.-2C</i>	Proportional band (for CH2 cool control)	100.0		
42	<i>I.-2C</i>	Reset time (for CH2 cool control)	0		
43	<i>d.-2C</i>	Rate time (for CH2 cool control)	0		
44	<i>oL.-2C</i>	MV lower limit (for CH2 cool control)	0.0		
45	<i>oH.-2C</i>	MV upper limit (for CH2 cool control)	100.0		
46	<i>rE.-2C</i>	Manual reset (for CH2 cool control)	50.0		
47	—	Unused	—		[Note]
48	—	Unused	—		“- - -” is displayed and setting is not possible.
49	—	Unused	—		
50	—	Unused	—		

Chapter 8. PROGRAM SETUP

8 - 1 Program Setup

Programs can be set up when the DCP302 is in the basic display state. This is sometimes referred to as “programming” in this manual.

If the DCP302 is not in the basic display state, press the DISP key to set the DCP302 to the basic display state.

Programming can be carried out more easily if the details of the setup are entered to the Programming Map Draft Form at the end of this manual before starting programming.

■ How to enter program setup

● Key operation

Press the FUNC key + the PROG key in the basic display state to enter program setup.

In the program setup state, the PRG LED on the console lights, and the decimal points in the program No. display and segment No. display light. However, note that the DCP302 does not enter the program setup state in the following cases:

- When in the constant-value operation mode (when constant-value operation data *modE* setting is 1)
- When key lock is active (variable parameter *LoC* is set to 2 or 4)

Also, the setup cannot be changed even if the DCP302 is in the program setup in the following case:

- When the program is protected (variable parameter *PrtC* is set to 1)

● Display start items

When the DCP302 enters the program setup state, display starts from the program No. and the segment No. pattern item.

■ Selecting the program No. to set up

There are two ways of selecting the program No. to set up:

- By selecting the program No. before entering program setup
- By selecting the program No. after entering program setup

● Selecting the program No. before entering program setup

To select the program No. press the PROG key or ↓ if the DCP302 is in the basic display state in the READY mode.

Handling Precautions

The program No. cannot be selected on the DCP302 when the program No. is being selected by external switch inputs.

For details, see 6-3 Program Selection (page 6-17).

● Selecting the program No. after entering program setup

Each press of the FUNC key + the PROG key in the program setup state increments the program No. When 19 is reached, the program No. returns to 1. Likewise, each press of the FUNC key + ↓ decrements the program No. When 1 is returned to, the program No. advances to 19.

However, note that when setup values are being entered (setting value is blinking) during program setup, press the ENT key first to quit entry of values and then press the FUNC key + the PROG key or the FUNC key + ↓ to change the program No.

When you select the program No. by this method, the display changes to the pattern item on the programming map.

This method can be used, for example, to select a program No. to set up a program other than the No. being operated in the RUN mode. It can also be used to select a program No. to set up a program other than the No. currently selected by external switch input.

■ Mode transition

The following diagram shows the transition between modes during program setup. The following page describes the various mode transition states ① to ⑯ in the diagram.

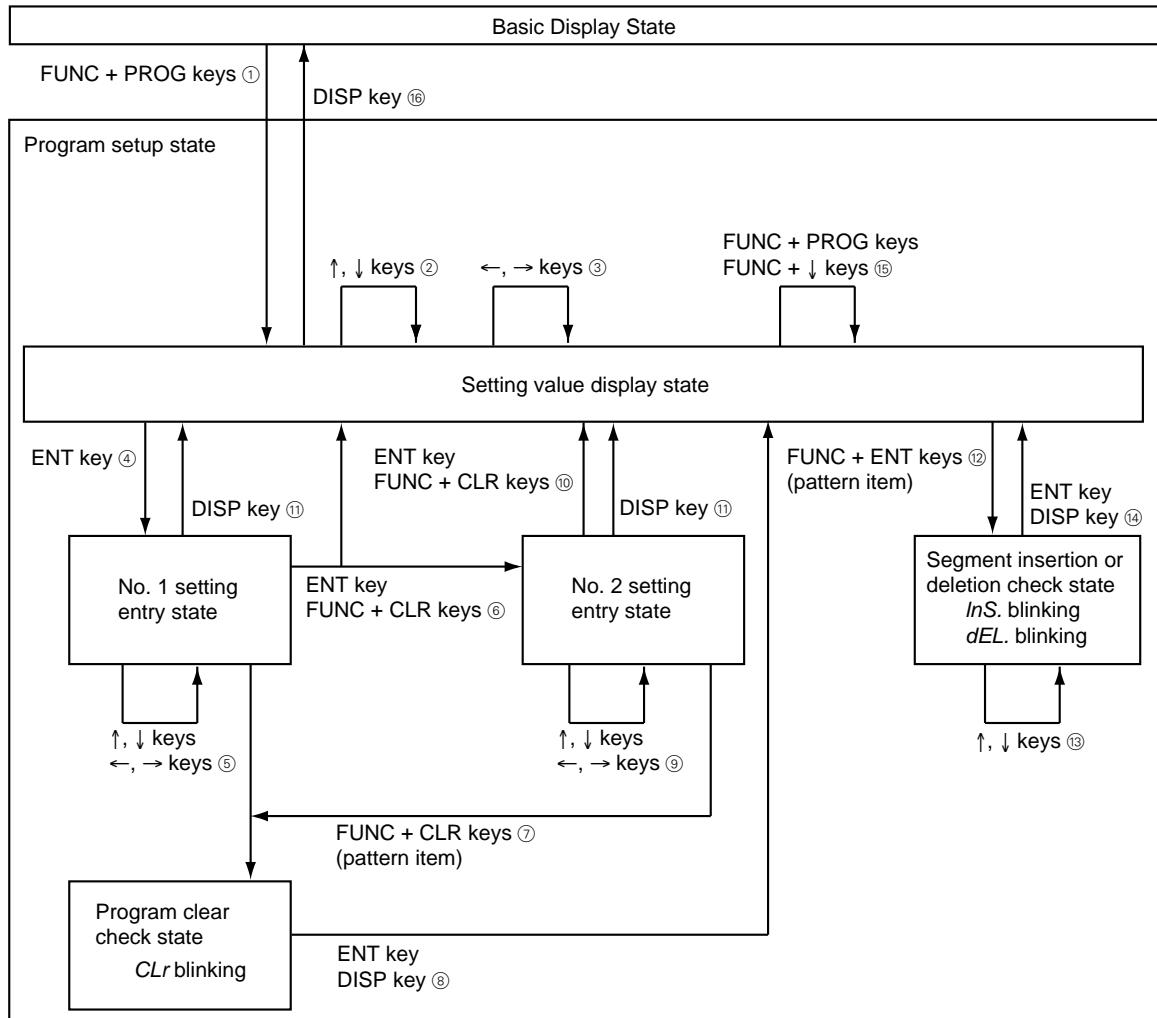

● Description of mode transition states

- ① Program setup is entered.
- ② Setup item on programming map is moved.
- ③ Segment on programming map is moved.
- ④ Entry of the No.1 setup is started.
- ⑤ No.1 setting value is incremented/decremented, and the blinking digit is moved.
- ⑥ Entry of No.1 setup is completed.
The ENT key stores the value being entered to memory.
With items having a No.2 setup, entry of the No.2 setup value is started. When the item does not have a No.2 setup, the setup display is redisplayed.
When the FUNC key + the CLR key are pressed at an event/time event item, the setting for that segment is cleared.
When the FUNC key + the CLR key are pressed at a G.Soak item, the setting for that segment is cleared.
- ⑦ Pressing the FUNC key + the CLR key for a pattern item causes “CLR.” to blink to confirm clearing of the program from that segment onwards.
However, note that the FUNC key + the ENT key are disabled for currently running programs.
- ⑧ The ENT key clears the program from that segment onwards.
The DISP key does not clear the program and the setup display is redisplayed.
- ⑨ No.2 setup setting value is incremented/decremented, and the blinking digit is moved.
- ⑩ Entry of No.2 setup is completed.
The ENT key stores the value being entered to memory.
When the FUNC key + the CLR key are pressed at an event/time event item, the setting for that segment is cleared.
- ⑪ Entry of values currently being entered is completed without them being stored to memory.
- ⑫ When the FUNC key + the ENT key are pressed at a pattern item, the display changes to the segment insert/delete screen, and “InS.” blinks.
However, note that the FUNC key + the ENT key is disabled for currently running programs.
- ⑬ “dEL.” displayed blinking by the ↓ key, and “InS.” is displayed blinking by the ↑ key.
- ⑭ If the ENT key is pressed at the “InS.” display, a segment is inserted. If the ENT key is pressed, a segment is “dEL.”.
If the DISP key is pressed, a segment is neither deleted nor inserted.
- ⑮ Press the FUNC key + the PROG key to increment program Nos., and the FUNC key + the ↓ key to decrement program Nos.
- ⑯ The basic display state is redisplayed.

■ Programming map

As shown in the figure below, the programming map is arranged in the form of a matrix with the segment Nos. aligned along the horizontal axis and program setup items arranged along the vertical axis.

The area surrounded by thick black lines indicates the items that can be designated by segment No. and program setup item in the program setup state.

←, → keys: Moves to the left or right (i.e. moves segments)

↑, ↓ keys: Moves up or down (i.e. moves program items).

The programming map below shows an example where segments No.1 to No.10 have been set up.

Example of programming map

Shaded items  cannot be moved.

Segment No.		1	2	10	11	12 to 30	Remarks
Program Items	① No.1 setting							
	② No.2 setting							
Pattern	① SP1	100	1000		100	----		*1
	② Time	0:30	3.00		10:00	----		
SP2	① SP2	200	500		200			
Event 1	① Operation point (ON time)	1000	----		----			*2
	② (OFF time)							
Event 2	① Operation point (ON time)	----	30		----			
	② (OFF time)							
Event 3	① Operation point (ON time)	0.00	0.00		0.00			
	② (OFF time)	0.01	0.01		0.01			
Time event 1	① ON time	----	0.00		----			*3
	② OFF time	----	1.00		----			
Time event 2	① ON time	----	1.00		----			
	② OFF time	----	2.00		----			
Time event 3	① ON time	----	2.00		----			
	② OFF time	----	3.00		----			
Time event 4	① ON time	----	----		----			
	② OFF time	----	----		----			
Time event 5	① ON time	----	----		0.00			
	② OFF time	----	----		----			
PID set No. (CH1)		1	2		8			*4
PDI set No. (CH2)		1	1		2			
G.Soak (CH1)		----	----		----			
G.Soak (CH2)		----	----		----			
PV start		1	1		1			*5
Cycle		0	0		0			
Pattern link		0	0		0			

*1 The No.10 segment is the final segment. A non-set segment is shown in the No.11 segment.

*2 As PV type event is selected as the PV type for events 1 and 2, only the No.1 setting can be set up. As time event is selected as the event type for event 3, the No.1 and No.2 settings can be set up.

*3 As all time events are selected as the event type in the time event, the No.1 and No.2 settings can be set up.

*4 This can be set as controller functions are selected for both channels CH1 and CH2, and PID is carried out.

*5 As these are setting items for each program, the display and setting are common for all segments.

■ Display details

The following figure shows the conventions used for displays in this manual.

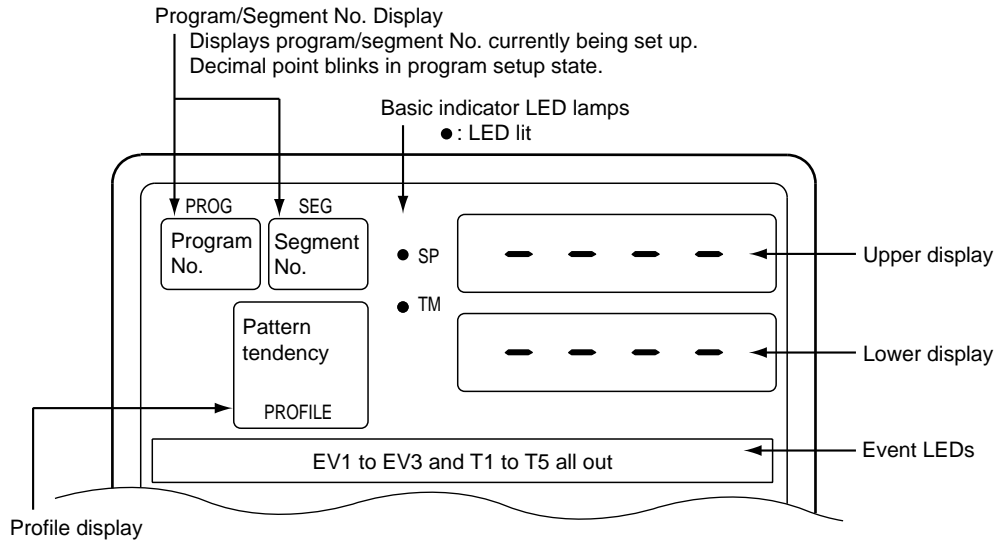

■ Setting up pattern items

- ① In the setting display state, move to the pattern item of the segment to be set up on the programming map.
- ② If you press the ENT key, the upper display starts blinking to indicate start of entry to the No.1 setup.
- ③ Press the ↑, ↓, ← or → key to set to the No.1 setup SP setting.
Setting range: SP1 lower to upper limit
(Set the SP1 limit in setup data C09 or C10.)
- ④ When you press the ENT key, blinking on the upper display stops. The lower display then starts blinking to indicate start of entry to the No.2 setup.
- ⑤ Press the ↑, ↓, ← or → key to set to the No.2 setup time setting.
Setting range: 0:00 to 99:59
(Select either of hours:minutes or minutes:seconds as the time unit in setup data C64. ":" is substituted by "." as it cannot be displayed.)
- ⑥ When you press the ENT key, blinking on the lower display stops.

● Display

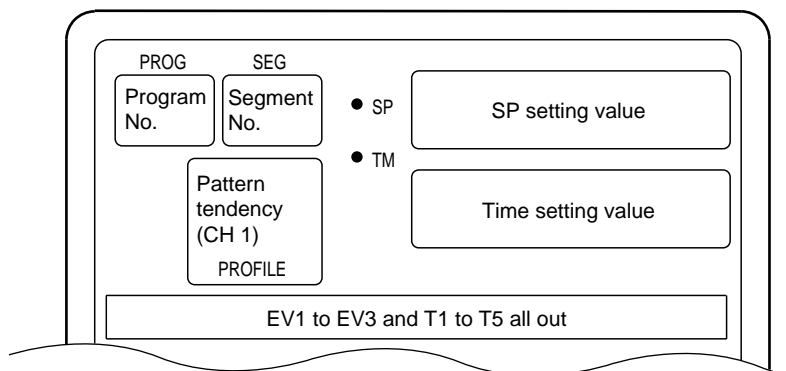

"- - -" is displayed for the SP and time setting values in non-set segments.

■ Setting up SP2 items

- ① In the setting display state, move to the SP2 item of the segment to be set up on the programming map.
- ② If you press the ENT key, the lower display starts blinking to indicate start of entry to the No.1 setup.
- ③ Press the ↑, ↓, ← or → key to set to the No.1 setup SP2 setting.
 Setting range: SP2 lower to upper limit
 (Set the SP2 limit in setup data C32 or C33.)
- ④ When you press the ENT key, blinking on the lower display stops.

● Display

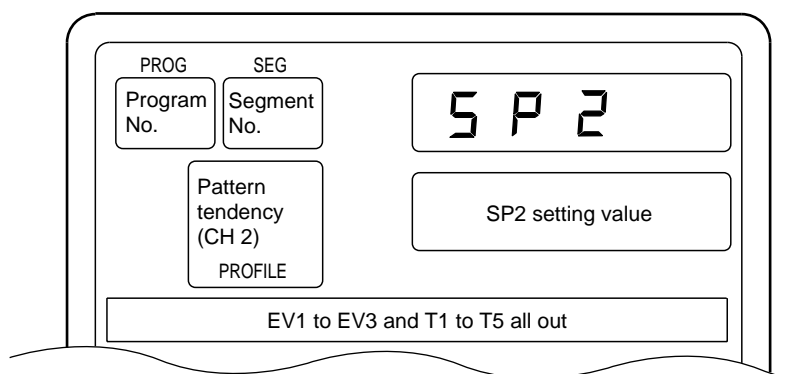

■ Setting up events 1 to 3 items

● When event type is PV type event

- ① In the setting display state, move to the event 1 to 3 items of the segment to be set up on the programming map.
- ② If you press the ENT key, the upper display starts blinking to indicate start of entry to the No.1 setup.
- ③ Press the ↑, ↓, ← or → key to set to the No.1 setup event operating point setting.
 Setting range: -1999 to +9999U
 0 to 9999U (in case of absolute value deviation event)
 -10.0 to +110.0% (in case of MV, MFB event)
- ④ When you press the ENT key, blinking on the upper display stops.
 (When the FUNC key + the CLR key are pressed, “- - - -” is redisplayed on the upper display and blinking stops.)

● Display (PV type event)

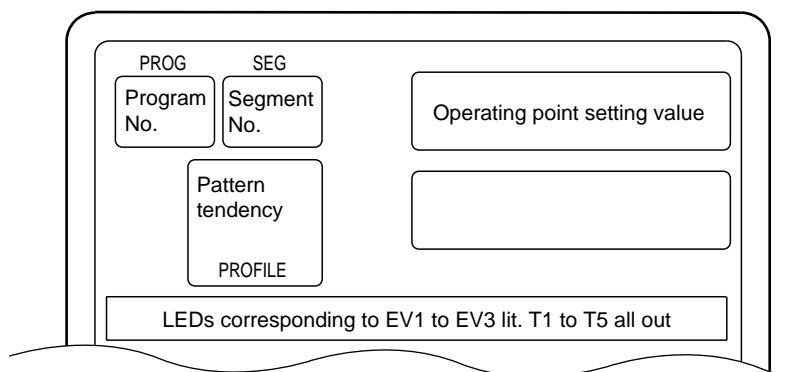

- “- - - -” is displayed for the setting values in non-set segments.
- When setup data C68 is set to 1, event 1 to 3 items on the programming map are skipped and not displayed.
- The profile display displays the trend of the SP pattern on the channel currently selected in the basic display state.

● When event type is time event

- ① In the setting display state, move to the event 1 to 3 items of the segment to be set up on the programming map.
- ② If you press the ENT key, the upper display starts blinking to indicate start of entry to the No.1 setup.
- ③ Press the ↑, ↓, ← or → key to set to the No.1 setup ON time setting.
Setting range: 0:00 to 99:59
(Select either of hours:minutes or minutes:seconds as the time unit in setup data C64. “:” is substituted by “.” as it cannot be displayed.)
- ④ When you press the ENT key, blinking on the upper display stops. The lower display then starts blinking to indicate start of entry to the No.2 setup.
(When the FUNC key + the CLR key are pressed, “- - - -” is redisplayed on both the upper and lower displays and blinking stops.)
- ⑤ Press the ↑, ↓, ← or → key to set to the No.2 setup ON time setting.
Setting range: ON time setting + 0:01 to 99:59
- ⑥ When you press the ENT key, blinking on the upper display stops.
(When the FUNC key + the CLR key are pressed, “- - - -” is redisplayed on the upper display and blinking stops.)

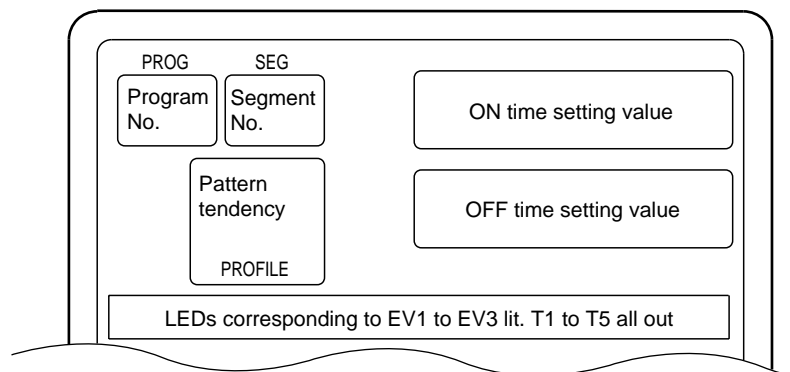

● Display (time event)

- “- - - -” is displayed for the setting values in non-set segments.
- When setup data C68 is set to 1, event 1 to 3 items on the programming map are all skipped and not displayed.
- When the event type is set to time event and the ON time is set to 99:59, “- - - -” is displayed for the ON time and the display does not blink. In this case, the OFF time cannot be set.
- When the event type is set to time event and the ON time is set higher than the time setting of the pattern item, event output at that segment is OFF. However, note that event output is ON when the mode changes to the END mode at segments whose ON time and pattern item time are equal.
- The profile display displays the trend of the SP pattern on the channel currently selected in the basic display state.

● When event type is controller status event

In this case, the event item on the programming map is skipped and not displayed.

■ Setting up time events 1 to 5

- ① In the setting display state, move to the event 1 to 5 items of the segment to be set up on the programming map.
- ② If you press the ENT key, the upper display starts blinking to indicate start of entry to the No.1 setup.
- ③ Press the ↑, ↓, ← or → key to set to the No.1 setup ON time setting.
Setting range: 0:00 to 99:59
(Select either of hours:minutes or minutes:seconds as the time unit in setup data C64. “:” is substituted by “.” as it cannot be displayed.)
- ④ When you press the ENT key, blinking on the upper display stops. The lower display then starts blinking to indicate start of entry to the No.2 setup.
(When the FUNC key + the CLR key are pressed, “- - -” is redisplayed on both the upper and lower displays and blinking stops.)
- ⑤ Press the ↑, ↓, ← or → key to set to the No.2 setup ON time setting.
Setting range: ON time setting + 0:01 to 99:59
- ⑥ When you press the ENT key, blinking on the upper display stops.
(When the FUNC key + the CLR key are pressed, “- - -” is redisplayed on the upper display and blinking stops.)

● Display

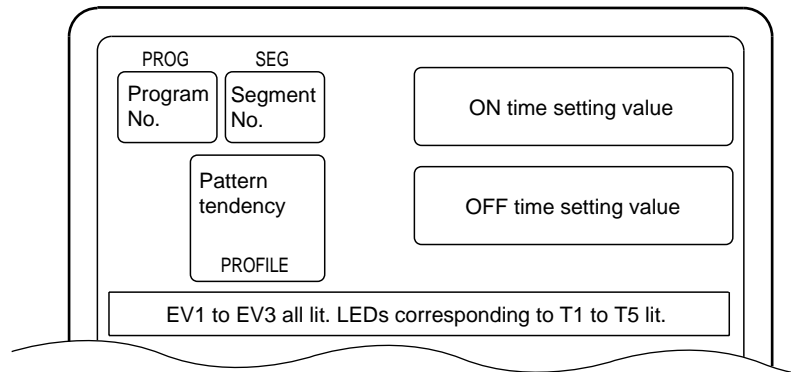

- “- - -” is displayed for the setting values in non-set segments.
- On models that do not support time events, event 1 to 5 items on the programming map are all skipped and not displayed. The table below shows time events by a ○.

Time event No. tt setting value	T1	T2	T3	T4	T5
0	○	○	○	○	○
1		○	○	○	○
2			○	○	○
3				○	○
4					○
5					

- When setup data C69 is set to 1, event 1 to 5 items on the programming map are all skipped and not displayed.

- When the ON time is set to 99:59, “- - -” is displayed as the OFF time, and the display does not blink. In this case, the OFF time cannot be set.
- When the ON time is set higher than the time setting of the pattern item, event output at that segment is OFF. However, note that event output is ON when the mode changes to the END mode at segments whose ON time and pattern item time are equal.
- The profile display displays the trend of the SP pattern on the channel currently selected in the basic display state.

■ Setting up PID set No. (CH1) items

- ① In the setting display state, move to the PID set No. (CH1) items of the segment to be set up on the programming map.
- ② If you press the ENT key, the lower display starts blinking to indicate start of entry to the No.1 setup.
- ③ Press the ↑, ↓, ← or → key to set to the No.1 setup PID set No. setting.
Setting range: 0 to 8 (non heat/cool models, or when setup data C44 setting is 1)
0 to 4 (heat/cool models and setup data C44 setting is 0)
- ④ When you press the ENT key, blinking on the upper display stops.

● Display

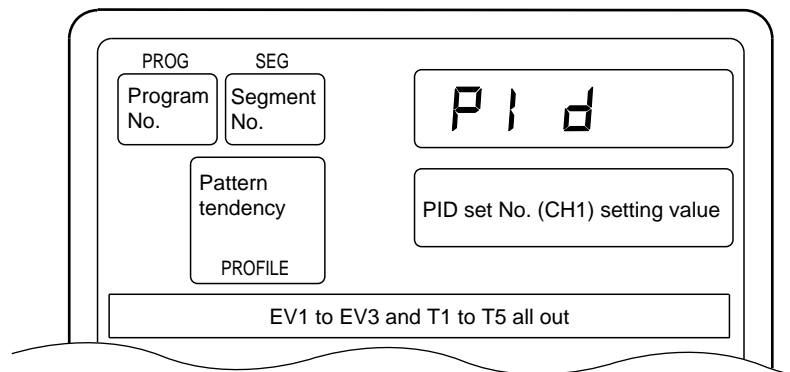

- When setup data C11 is set to 1 and PID set auto-switching ON (CH1) is selected, the PID set No. (CH1) items on the programming map are skipped and not displayed.
- On models whose CH1 output is current output, when setup data C18 is set to 1 and the DCP302 is selected for use as a programmer, the PID set No. (CH1) items on the programming map are skipped and not displayed.
- On 3D output models, when setup data C44 is set to 0 and C45 is set to 1, and 3-position control is selected on channel 1, the PID set No. (CH1) items on the programming map are skipped and not displayed.
- When setup data C70 is set to 1, the PID set No. (CH1) items on the programming map are all skipped and not displayed.
- When the PID set No. (CH1) setting is set to 0, this means that the PID set No. (CH1) of the previous segment is continued. When the PID set No. (CH1) setting is set to 0 in the No.1 segments, this is the same as being set to 1.
- The profile display displays the trend of the SP pattern on the channel currently selected in the basic display state.

■ Setting up PID set No. (CH2) items

- ① In the setting display state, move to the PID set No. (CH2) items of the segment to be set up on the programming map.
- ② If you press the ENT key, the lower display starts blinking to indicate start of entry to the No.1 setup.
- ③ Press the ↑, ↓, ← or → key to set to the No.1 setup PID set No. setting.
 Setting range: 0 to 8 (non heat/cool models, or when setup data C44 setting is 0)
 0 to 4 (heat/cool models and setup data C44 setting is 1)
- ④ When you press the ENT key, blinking on the upper display stops.

● Display

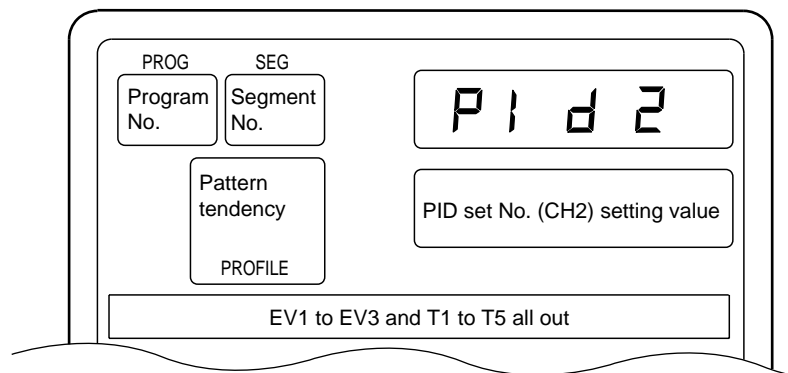

- When setup data C34 is set to 1 and PID set auto-switching ON (CH2) is selected, the PID set No. (CH2) items on the programming map are skipped and not displayed.
- On models whose CH2 output is current output, when setup data C41 is set to 1, and the DCP302 is selected for use as a programmer, the PID set No. (CH2) items on the programming map are skipped and not displayed.
- On 3D output models, when setup data C44 is set to 1 and C45 is set to 1 and 3-position control is selected on channel 2, the PID set No.(CH2) items on the programming map are skipped and not displayed.
- When setup data C70 is set to 1, the PID set No. (CH2) items on the programming map are all skipped and not displayed.
- When the PID set No. (CH2) setting is set to 0, this means that the PID set No. (CH2) of the previous segment is continued. When the PID set No. (CH2) setting is set to 0 in the No.1 segments, this is the same as being set to 1.
- The profile display displays the trend of the SP pattern on the channel currently selected in the basic display state.

■ Setting up G.Soak (guarantee soak) (CH1) items

- ① In the setting display state, move to the G.Soak (CH1) item of the segment to be set up on the programming map.
- ② If you press the ENT key, the lower display starts blinking to indicate start of entry to the No.1 setup.
- ③ Press the ↑, ↓, ← or → key to set to the G.Soak width (CH1) setting.
Setting range: 0 to 1000U
- ④ When you press the ENT key, blinking on the lower display stops.
(When the FUNC key + the CLR key are pressed, the lower display returns to “- - -” and blinking stops.)

● Display

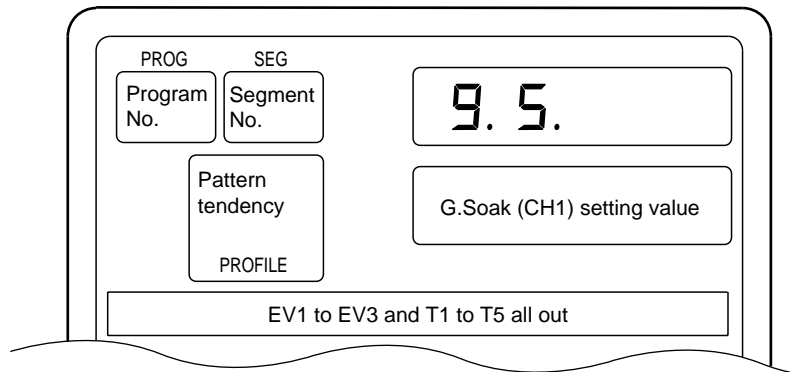

- “- - -” is displayed for the setting values in non-set segments.
The G.Soak function on channel CH1 does not work in non-set segments.
- When setup data **C70** is set to 1, G.Soak (CH1) items on the programming map are skipped and not displayed.
- The profile display displays the trend of the SP pattern on the channel currently selected in the basic display state.

■ Setting up G.Soak (guarantee soak) (CH2) items

- ① In the setting display state, move to the G.Soak (CH2) item of the segment to be set up on the programming map.
- ② If you press the ENT key, the lower display starts blinking to indicate start of entry to the No.1 setup.
- ③ Press the ↑, ↓, ← or → key to set to the G.Soak width (CH2) setting.
Setting range: 0 to 1000U
- ④ When you press the ENT key, blinking on the lower display stops.
(When the FUNC key + the CLR key are pressed, the lower display returns to “- - -” and blinking stops.)

● Display

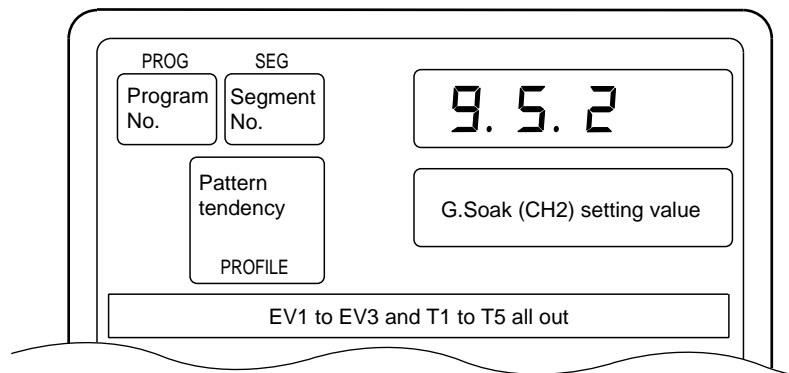

- “- - -” is displayed for the setting values in non-set segments.
The G.Soak function on channel CH2 does not work in non-set segments.
- When setup data **C70** is set to 1, G.Soak (CH2) items on the programming map are skipped and not displayed.
- The profile display displays the trend of the SP pattern on the channel currently selected in the basic display state.

■ Setting up PV start items

- ① In the setting display state, move to the PV start items on the programming map.
(The settings are common to all segments as the PV start items are setting items provided for each program.)
- ② If you press the ENT key, the lower display starts blinking to indicate start of entry to the No.1 setup.
- ③ Press the ↑, ↓, ← or → key to set to the No.1 setup PV start setting.
Setting range: 0 to 2
0: PV start disabled
1: PV start enabled on channel CH1
2: PV start enabled on channel CH2
- ④ When you press the ENT key, blinking on the lower display stops.

● Display

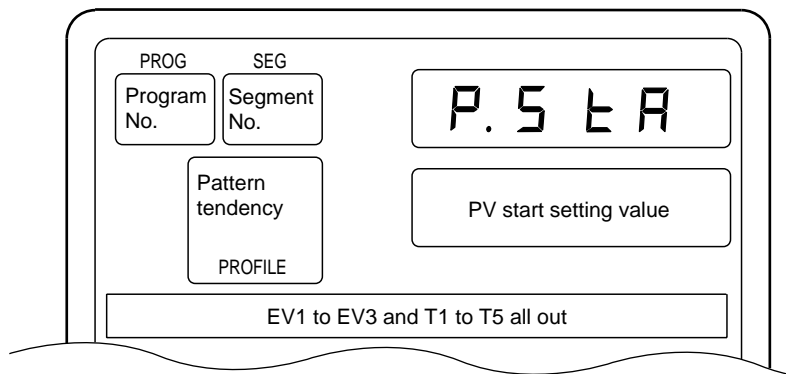

- The settings are common to all segments as the PV start items are setting items provided for each program.
- When setup data *C71* is set to 1, PV start items on the programming map are skipped and not displayed.
- The profile display displays the trend of the SP pattern on the channel currently selected in the basic display state.

■ Setting up cycle items

- ① In the setting display state, move to the cycle items on the programming map.
(The settings are common to all segments as the cycle items are setting items provided for each program.)
- ② If you press the ENT key, the lower display starts blinking to indicate start of entry to the No.1 setup.
- ③ Press the ↑, ↓, ← or → key to set to the No.1 setup cycle setting.
Setting range: 0 to 9999 times
- ④ When you press the ENT key, blinking on the lower display stops.

● Display

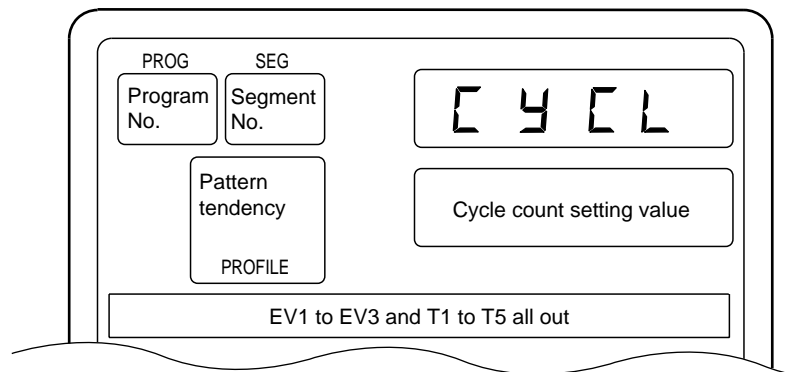

- The settings are common to all segments as the cycle items are setting items provided for each program.
- When setup data C71 is set to 1, cycle items on the programming map are skipped and not displayed.
- The profile display displays the trend of the SP pattern on the channel currently selected in the basic display state.

■ Setting up pattern link items

- ① In the setting display state, move to the pattern link items on the programming map.
(The settings are common to all segments as the pattern link items are setting items provided for each program.)
- ② If you press the ENT key, the lower display starts blinking to indicate start of entry to the No.1 setup.
- ③ Press the ↑, ↓, ← or → key to set to the No.1 setup pattern link setting.
Setting range: 0 to 19
0: Pattern link disabled
1 to 19: Pattern link destination program No.
- ④ When you press the ENT key, blinking on the lower display stops.

● Display

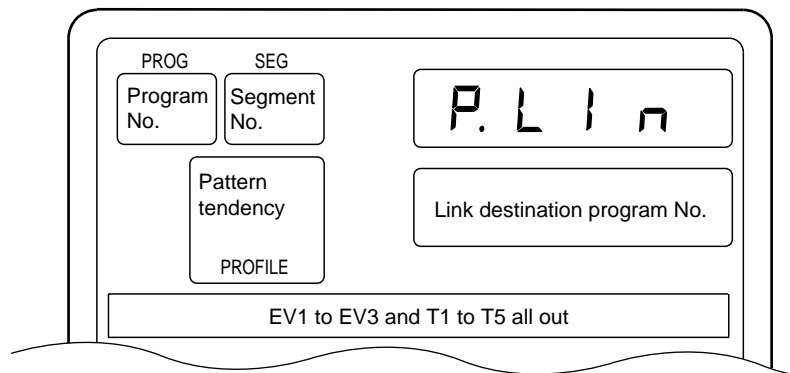

- The settings are common to all segments as the pattern link items are setting items provided for each program.
- When setup data C71 is set to 1, pattern link items on the programming map are skipped and not displayed.
- The profile display displays the trend of the SP pattern on the channel currently selected in the basic display state.

■ Deleting programs

- ① In the setting display state, move to the pattern item of the segment from which the program is to be deleted on the programming map.
To delete all the segments of a particular program, move to the No.1 segment.
- ② If you press the ENT key, the upper display starts blinking to indicate start of entry to the No.1 setup.
(So far, the procedure is the same as that for setting the pattern item.)
- ③ If you press the FUNC key + the CLR key, the display changes to confirm clearing of the program, and “CLr.” is displayed blinking in the upper display.
- ④ Press the ENT key to execute deletion of the program.
- ⑤ The DCP302 returns to the setting display state, both the upper and lower displays change to “- - -” to indicate no setting.

● Display

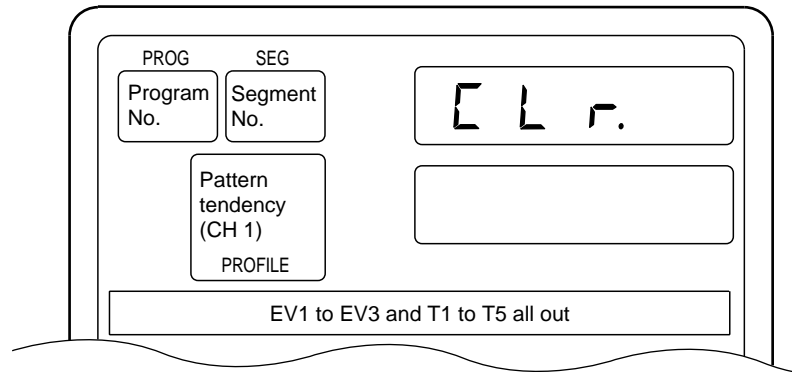

- In the above procedure, the FUNC key + the CLR key are pressed while entering values (SP setting value) to the No.1 setup. However, the program can also be deleted by pressing the FUNC key + the CLR key while entering values (time setting value) to the No.2 setup.
- “- - -” is displayed for the SP and time setting values in non-set segments.
- Currently running (RUN, HOLD, FAST, END) programs cannot be deleted.

■ Inserting and deleting segments

- ① In the setting display state, move to the pattern item of the segment where the segment is to be inserted or deleted on the programming map.
- ② If you press the FUNC key + the ENT key, the display changes to confirm insertion of the segment, and “InS.” is displayed blinking in the upper display.
- ③ If you press the ↑ key, the display changes to confirm insertion of the segment, and “InS.” is displayed blinking in the upper display.
If you press the ↓ key, the display changes to confirm deletion of the segment, and “dEL.” is displayed blinking in the upper display.
- ④ If you press the ENT key while “InS.” is displayed on the upper display, the segment is inserted.
If you press the ENT key while “dEL.” is displayed on the upper display, the segment is deleted.
- ⑤ The setting display state is redisplayed.

● Display (inserting segment)

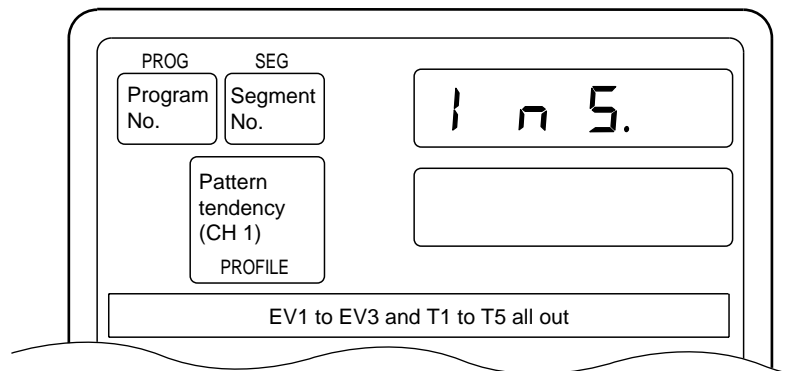

● Display (deleting segment)

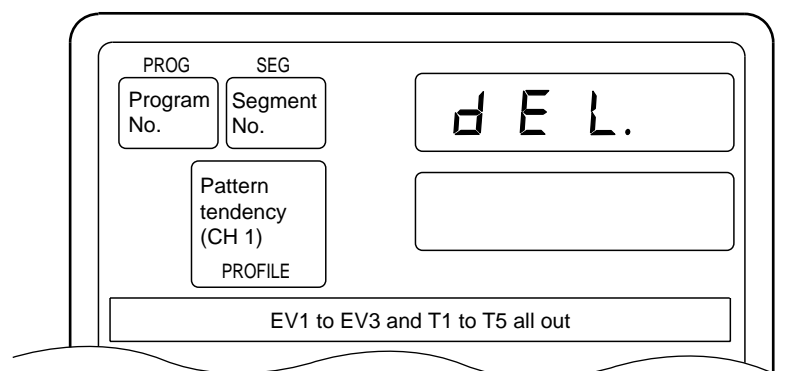

- When you insert a segment, a new segment is automatically created at the currently displayed segment No., and all segment Nos. onward are incremented by one. The setting of the inserted segment is as follows:
SP1, SP2 setting value: Same value as original segment before the new segment was inserted
Time setting value: 0:10
Events, time events and G.Soak (CH1 and CH2) are not set, and the PID set No. (CH1 and CH2) is set to 0.
- If you try to insert a segment in a program already containing 30 segments, pressing the ENT key will not insert the segment.

- When you delete a segment, the next segment shifts down to the currently displayed segment No. and subsequent segment Nos. are decremented by one. When you delete the last segment, the display changes to “- - -” indicating that nothing is set.
- Segments cannot be inserted or deleted from currently running (RUN, HOLD, FAST, END) programs.

8 - 2 Copying Programs

The DCP302 can be set for copying programs in the program operation READY mode in the basic display state. If the DCP302 is not in the basic display state, press the DISP key.

■ Operation

- ① Set the DCP302 to the program operation READY mode.
Set variable parameter *LoC* to either of 0, 1 or 3, and variable parameter *PrtC* to 0.
- ② In the basic display state, press the PROG key or the ↓ key to select the copy source program No.
However, note that the program No. cannot be selected on the console when controlling the DCP302 by external switch inputs.
For details, see 6-3 Program Selection (page 6-10).
- ③ If you press the ↑ key + the PROG key, “CoPY” is displayed on the upper display, and the copy destination program No. is displayed on the lower display.
- ④ If you press the ↑ key or the ↓ key, current non-set program Nos. are displayed blinking in order as the copy destination program No.
When there are no non-set program Nos., “- - -” is displayed on the lower display.
- ⑤ If you press the ENT key, program copy is executed, and the lower display stops blinking. To repeat the procedure, carry out steps ④ and ⑤ again.
- ⑥ To quit program copy, press the DISP key.

● Display

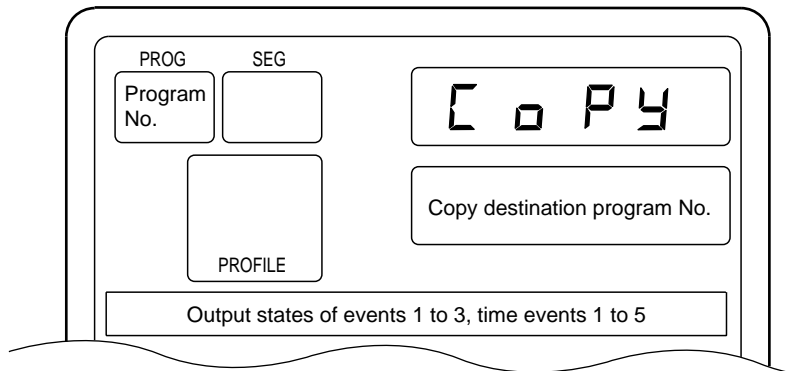

8 - 3 General Reset

A general reset can be executed when the DCP302 is in the READY AUTO mode in the basic display state. If the DCP302 is not in the basic display state, press the DISP key.

A “general reset” involves the following operations:

- Clearing all program setups for program Nos.1 to 19
- Returning parameter setups to their factory settings
- Changing the mode to the program operation READY AUTO mode

■ Operation

- ① Set the DCP302 to the READY AUTO mode.
Set variable parameter *LoC* and *PrtC* to 0.
- ② If you press the FUNC key + the CLR key + the DISP key in the basic display state, the display changes to confirm execution of general reset, and “*g.rES*” is displayed on the upper display.
- ③ If you press the ENT key, the general reset is executed, and operation starts from initialization when the power is turned ON.
If you press the DISP key, general reset is not executed, and the DCP302 returns to the basic display state.

● Display

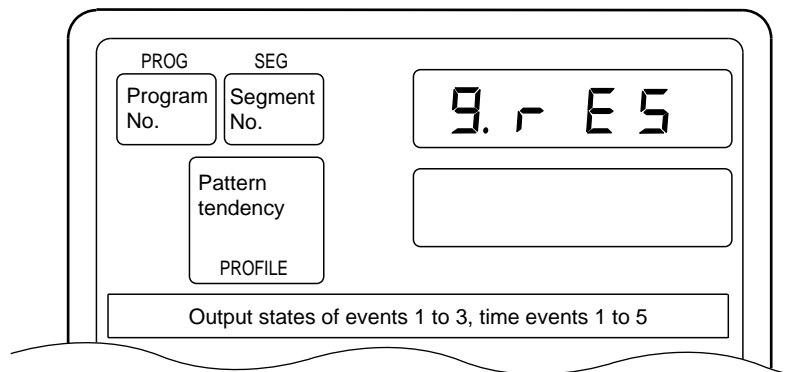

In the constant-value operation mode, all of the program No., segment No. and profiles displays are cleared.

- If a RAM backup error occurs when the power is turned ON, the display changes to confirm general reset without pressing any of the keys on the console, and “*g.rES*” is displayed in the upper display.
If you press the ENT key, the general reset is executed. Other keys, however, cannot be operated.
- The following setup data items are not returned to their factory settings.
 - C02, C03*: Save setting values.
 - C04, C05*: These are set to 0 when the input 1 range type is set to linear.
 - C06*: This is set to 1000 when the input 1 range type is set to linear.
 - C22, C23*: Save setting values.
 - C24, C25*: These are set to 0 when the input 2 range type is set to linear.
 - C26*: This is set to 1000 when the input 2 range type is set to linear.
 - C75, C76, C77*: Save setting values.

However, note that if a RAM backup error occurs when the power is turned ON, *C02, C03, C22, C75, C76* and *C77* settings become 0 and *C23* setting becomes 128

Chapter 9. MAINTENANCE & TROUBLESHOOTING

9 - 1 Maintenance

Cleaning: Clean off dirt on the DCP302 with a soft, dry cloth.

Replacing parts: Only authorized personnel are allowed to replace parts. The users should never replace parts on their own.

Replacing fuse: Use only specified fuses when replacing fuses on the power supply wiring.

9 - 2 Self-diagnostics and Alarm Code Display

Self-diagnostics functions are incorporated into the DCP302. See “Alarm Categories” on page 9-3 for details of alarm codes that are displayed as a result of self-diagnostics.

■ Self-diagnostics at power ON

● PROM error

An error in the system program stored to PROM has been detected. However, note that not all PROM errors are detected. Some errors are detected as controller operation errors.

The corresponding alarm code is displayed when this error is detected.

● Adjustment value error

An error in the analog I/O adjustment data stored to volatile memory has been detected.

The corresponding alarm code is displayed when this error is detected.

● RAM backup error

An error in the RAM backup function has been detected.

When this error is detected, a general reset is carried out.

An alarm code is not displayed for this error.

● Board configuration error

An error in the board configuration (combination of different PCBs) has been detected according to the model No. of the DCP302.

The corresponding alarm code is displayed when this error is detected.

■ Self-diagnostics at each sampling cycle

● Analog input error

A probable cause of this error is a disconnected analog input. This error is detected when the analog input is outside the -10.0 to +110.0% range.

The corresponding alarm code is displayed when this error is detected.

● MFB (motor feedback) input error

Disconnected MFB input or a short-circuit has been detected on 2G output models.

The corresponding alarm code is displayed when this error is detected.

● A/D converter error

Trouble has been detected in the A/D converter used on the analog input circuit.

The corresponding alarm code is displayed when this error is detected.

■ Intermittent self-diagnostics during operation

● Program error

An error in the program setup data stored to backed up RAM has been detected.
The corresponding alarm code is displayed when this error is detected.

● Parameter error

An error in the parameter setup data stored to backed up RAM has been detected.
The corresponding alarm code is displayed when this error is detected.

● Low battery voltage error

A drop in the battery voltage for backing up RAM data has been detected.
When the low battery voltage error is detected, the BAT LED on the console blinks.

■ Self-diagnostics only when certain functions are operating

● MFB (motor feedback) adjustment error

This error is detected when MFB automatic adjustment is not going smoothly on 2G output models.

The corresponding alarm code is displayed when this error is detected.

To clear this alarm, either execute automatic adjustment again or turn the power OFF then back ON again.

■ Alarm code display

When an input error or controller error is detected in the basic display state, the alarm code and regular display are displayed alternately every second on the program No. and segment No. displays. The table below shows alarm codes and alarm descriptions.

When two or more alarms occur at the same time, the alarm codes are displayed from the smallest number upwards alternately with the regular display.

However, note that when setup data C67 has been set to "1", alarm codes are not displayed.

■ Alarm categories

PV range alarm groups: AL01 to AL16

Controller alarm groups: AL70 to AL99, and low battery voltage

(BAT LED on console blinks in case of low battery voltage.)

Alarm Code	Alarm Name	Description	Remedy
AL01	Input 1 over-range	Input 1 has exceeded 110% FS	Check input 1
AL02	Input 1 under-range	Input 1 has fallen below -10% FS	
AL03	Input 2 over-range	Input 2 has exceeded 110% FS	Check input 2
AL04	Input 2 under-range	Input 2 has fallen below -10% FS	
AL07	Input 1 RTD disconnection A	RTD line A is disconnected.	Check line of RTD (resistance temperature detector) connected to input 1 for disconnection, and terminal connections.
AL08	Input 1 RTD disconnection B	RTD line B or lines ABC are disconnected.	
AL09	Input 1 RTD disconnection C	RTD line C is disconnected.	
AL10	MFB disconnection	MFB (Y, T, G) line(s) is disconnected.	Check MFB wiring.
AL11	MFB short-circuit	Y-G line or Y-T-G line is short-circuited.	
AL12	MFB adjustment impossible	Faulty wiring, motor incompatibility etc.	Check wiring of MFB switching relay or motor specifications.
AL13	Input 2 RTD disconnection A	RTD line A is disconnected.	Check line of RTD (resistance temperature detector) connected to input 2 for disconnection, and terminal connections.
AL14	Input 2 RTD disconnection B	RTD line B or lines ABC are disconnected.	
AL15	Input 2 RTD disconnection C	RTD line C is disconnected.	
AL16	Temperature operation error	The dry-bulb/wet-bulb temperature is out of range 0 to 100°C.	Check input 1 and input 2
AL70	A/D1 malfunction	A/D converter 1 has malfunctioned.	Ask for repair.
AL71	A/D2 malfunction	A/D converter 2 has malfunctioned.	
AL81	Board configuration error	Faulty board configuration	Ask for repair.
AL83	Cold junction compensation impossible	Cold junction compensation of input 2 thermocouple cannot be carried out. Damaged program setup data	Either set input 1 to the thermocouple range, or set so that cold junction compensation is carried out outside the DCP32.
AL96	Program error	Damaged parameter setup data	Check program setup, and reset damaged data. *1
AL97	Parameter error	Damaged analog input/output adjustment data	Check parameter setup, and reset damaged data. *2
AL98	Adjustment value error	Damaged system program	Ask for repair.
AL99	PROM error		Ask for repair.

*1 AL96 goes out even if program setup data other than the damaged data is reset.

*2 AL97 goes out even if parameter setup data other than the damaged data is reset.

9 - 3 Trouble during Key Entry

This section describes trouble that occurs during key entry and the necessary action to take.

■ Trouble in basic display state

● Pressing the PROG key does not change the program No.

Cause	Remedy
Program selection by external switch input not 0.	Set all external switch inputs RSW8 to 12 OFF.
The DCP302 is not in the READY mode.	Reset the DCP302 (PROG + RUN/HOLD key) to set it to the READY mode.
The DCP302 is in the constant-value operation mode.	Set constant-value operation data <i>modE</i> setting to 0.
Key lock is enabled.	Set variable parameter <i>LoC</i> setting to 0 to 2.

● Pressing the ↓ key does not change the program No.

Cause	Remedy
Program selection by external switch input not 0	Set all external switch inputs RSW8 to 12 OFF.
The DCP302 is not in the READY mode.	Reset the DCP302 (PROG + RUN/HOLD key) to set it to the READY mode.
The DCP302 is in the constant-value operation mode.	Set constant-value operation data <i>modE</i> setting to 0.
Set the DCP302 to the entry changeable display state by ↓ or ↑ key in MANUAL mode	Press DISP key.
Key lock is enabled.	Set variable parameter <i>LoC</i> setting to 0 to 2.

● Pressing the RUN/HOLD key does not change the DCP302 to the RUN mode.

Cause	Remedy
The currently selected program in READY mode has not been set up.	Select an already set up program
The DCP302 is in the END mode.	Reset the DCP302 (PROG + RUN/HOLD key) to set it to the READY mode.
Key lock is enabled.	Set variable parameter <i>LoC</i> setting to 0 to 2.

● Pressing the RUN/HOLD key does not change the DCP302 to the HOLD mode.

Cause	Remedy
The DCP302 is in the READY or FAST mode.	RUN mode is entered from READY or FAST mode. Press RUN/HOLD key again.
The DCP302 is in the END mode.	Reset the DCP302 (PROG + RUN/HOLD key) to set it to the READY mode.
The DCP302 is in the constant-value operation mode.	Set constant-value operation data <i>modE</i> setting to 0.
Key lock is enabled.	Set variable parameter <i>LoC</i> setting to 0 to 2.

● Pressing the PROG key + the RUN/HOLD key does not reset the DCP32.

“Reset in the program operation mode” refers to switching to the READY mode and returning to the No.1 segment.

“Reset in the constant-value mode” refers to switching to the READY mode.

Cause	Remedy
The DCP302 is in the READY mode.	Press RUN/HOLD key to set the DCP302 to the RUN mode. (The DCP302 can be reset in case of external switch input or communications even in the READY mode.)
Key lock is enabled.	Set variable parameter <i>LoC</i> setting to 0 to 2.

● Pressing the PROG key + the DISP key does not advance the program.

Cause	Remedy
The DCP302 is in the READY mode.	Press RUN/HOLD key to set the DCP302 to the RUN mode. (The DCP302 can be reset in case of external switch input or communications even in the READY mode.)
The DCP302 is in the END mode.	Reset the DCP302 (PROG + RUN/HOLD key) to set it to the READY mode, and press RUN/HOLD key again to set it to the RUN mode.
The DCP302 is in the constant-value operation mode.	Set constant-value operation data <i>modE</i> setting to 0.
Key lock is enabled.	Set variable parameter <i>LoC</i> setting to 0 to 2.

● Pressing the FUNC key + the → key does not change the DCP302 to the FAST mode.

Cause	Remedy
The DCP302 is in the READY mode.	Press RUN/HOLD key to set the controller to the RUN mode.
The DCP302 is in the END mode.	Reset the DCP302 (PROG + RUN/HOLD key) to set it to the READY mode, and press RUN/HOLD key again to set it to the RUN mode.
The DCP302 is in the constant-value operation mode.	Set constant-value operation data <i>modE</i> setting to 0.
Key lock is enabled.	Set variable parameter <i>LoC</i> setting to 0 to 2.

● Pressing the A/M key does not change the DCP302 to the MANUAL mode.

Cause	Remedy
3-position-proportional control is selected on a 3D output model.	Set setup data <i>C45</i> setting to 0 and switch to PID control from 3-position-proportional control.
Key lock is enabled.	Set variable parameter <i>LoC</i> setting to 0 to 2.

● Pressing the A/M key does not change the DCP302 to the AUTO mode.

Cause	Remedy
Key lock is enabled.	Set variable parameter <i>LoC</i> setting to 0 to 2.

● Pressing the AT key does not start auto-tuning (AT).

Cause	Remedy
The DCP302 is in the READY mode.	Press RUN/HOLD key to set the DCP302 to the RUN mode.
The DCP302 is in the MANUAL mode.	Press A/M to set the DCP302 to the AUTO mode.
The input of currently displayed channel is over-range.	Correctly wire input to correct input state.
The currently displayed channel is set not to execute AT.	Set variable parameter <i>At</i> setting or variable parameter 2 <i>At.2</i> setting to other than 0.
The currently displayed channel is set to current output, and the DCP302 is selected for use as a programmer.	Set setup data <i>C18</i> , <i>C41</i> setting to 0.
The currently displayed channel is set to heat/cool output.	AT cannot be executed by 3D and 5K outputs.
Key lock is enabled.	Set variable parameter <i>LoC</i> setting to 0 to 2.

● Pressing the AT key does not cancel auto-tuning (AT).

Cause	Remedy
Key lock is enabled.	Set variable parameter <i>LoC</i> setting to 0 to 2.
The currently displayed channel is in error	Press the FUNC key + DISP key to switch the currently displayed channel.

● Pressing the ↑ key and the ↓ key does not change output in the MANUAL mode.

Cause	Remedy
The DCP302 is selected for use as a programmer.	Press the DISP key until the screen for displaying SP is displayed.
The DCP302 is selected for use as a SPw programmer on CH2 of a temperature/humidity operation model.	Set variable parameter <i>Ch.2</i> to 2, and press the DISP key in the basic display state until the screen for displaying SPw is displayed.

● Pressing the FUNC key + the PROG key does not change the program setup state on the DCP302.

Cause	Remedy
The DCP302 is in the constant-value operation mode.	Set constant-value operation data <i>modE</i> setting to 0.
Key lock is enabled	Set variable parameter <i>LoC</i> setting to 0, 1 or 3.

● Pressing the ↑ key + the PROG key does not set the DCP302 to the program copy state.

Cause	Remedy
The DCP302 is in a mode other than READY mode.	Reset the DCP302 (PROG + RUN/HOLD key) to set it to the READY mode.
The program of the currently selected program No. is not set up.	Select a program No. whose program is already set.
The DCP302 is in the constant-value operation mode.	Set constant-value operation data <i>modE</i> setting to 0.
The program is protected.	Set variable parameter <i>PrtC</i> setting to 0.
Key lock is enabled.	Set variable parameter <i>LoC</i> setting to 0, 1 or 3.

● Pressing the FUNC key + the CLR key + the DISP key does not apply a general reset.

Cause	Remedy
The DCP302 is in a mode other than the READY mode.	Reset the DCP302 (PROG + RUN/HOLD key) to set it to the READY mode.
The mode is the MANUAL mode.	Press A/M to set the controller to the AUTO mode.
Memory is protected.	Set variable parameter <i>PrtC</i> setting to 0.
Key lock is enabled.	Set variable parameter <i>LoC</i> setting to 0, 1 or 3.

■ Troubles in the parameter setup state

● Pressing the PARA key in setting group selection does not display a setting group other than *PARA*.

Cause	Remedy
Key lock is enabled.	Set variable parameter <i>LoC</i> setting to 0, 1 or 3.

● Pressing the PARA key in setting group selection does not display the SEt setting group.

Cause	Remedy
Key lock is enabled.	Set variable parameter <i>LoC</i> setting to 0 or 3.

● Pressing the ENT key does not set the DCP302 to the setting entry state.

Cause	Remedy
"- - -" is displayed on the lower display.	This cannot be displayed nor set. This item sometimes can be displayed or set by changing the setting of related items.
Unchangeable data is displayed on the lower display.	This is a display-only item.

● Pressing the PARA key in the parameter setting entry state does not change the DCP302 to the setting group selection state, and the setting entry state continues.

Cause	Remedy
The DCP302 displays items by PARA key assignment.	Press DISP key to return the DCP302 to the basic display state, and press FUNC + PARA key.

■ Troubles in the program setup state

● Pressing the ENT key does not change the DCP302 to the setting entry state.

Cause	Remedy
The program setup cannot be changed.	Set variable parameter <i>PrtC</i> setting to 0.

● Repeatedly pressing the ↑ key and the ↓ key does not change items.

Cause	Remedy
The pattern item has not been set.	Set SP and time data.
Programming items are set to "display OFF".	All setup data C68 to C71 settings are "1". Set necessary items to 0.

● **Event items cannot be displayed by Repeatedly pressing the ↑ key and the ↓ key.**

Cause	Remedy
Event type is controller status event.	Set event type (<i>Et1</i> , <i>Et2</i> , <i>Et3</i>) in event configuration data to one of 1 to 11 or 50.
Programming items are set to "display OFF".	Set setup data <i>C68</i> setting to 0.

● **Repeatedly pressing the ↑ key and the ↓ key does not display time events.**

Cause	Remedy
Time event is assigned to segment No. event.	Change event configuration data <i>tt</i> setting and assign to time event.
This model does not support time events.	Select a model that supports time events (option).
Programming items are set to "display OFF".	Set setup data <i>C69</i> setting to 0.

● **Repeatedly pressing the ↑ key and the ↓ key does not display PID set items (CH1) and PID set items (CH2).**

Cause	Remedy
PID set auto-switching is set to ON.	Set setup data <i>C11</i> setting or <i>C34</i> setting to 0.
The DCP302 is set to programmer function by current output.	Set setup data <i>C18</i> setting or <i>C41</i> setting to 0.
3-position control is selected on a 3D output model.	Set setup data <i>C45</i> setting to 0 and switch to PID control from 3-position control.
Programming items are set to "display OFF".	Set setup data <i>C70</i> setting to 0.

● **Repeatedly pressing the ↑ key and the ↓ key does not display G.Soak items (CH1) and G.Soak items (CH2).**

Cause	Remedy
Programming items are set to "display OFF".	Set setup data <i>C70</i> setting to 0.

● **Repeatedly pressing the ↑ key and the ↓ key does not display PV start items, cycle items and pattern link items.**

Cause	Remedy
Programming items are set to "display OFF".	Set setup data <i>C71</i> setting to 0.

● **Pressing the FUNC key + the ENT key does not confirm insertion/deletion of segments.**

Cause	Remedy
The program setup cannot be changed.	Set program parameter <i>PrtC</i> setting to 0.
The program being set up is being operated (RUN, HOLD, FAST, END).	Reset the DCP302 (PROG + RUN/HOLD key) to set it to the READY mode.
Not pattern item on programming map	Move to pattern item on programming map.
Pattern item of non-set segment on programming map	Either move to already set up segment, or set up segment.

-
- Pressing the FUNC key + the CLR key during entry of pattern items does not confirm program deletion.

Cause	Remedy
The program being set up is being operated (RUN, HOLD, FAST, END).	Reset the DCP302 (PROG + RUN/HOLD key) to set it to

9 - 4 Motor Adjustment is Impossible

There are two ways of wiring a motor to the DCP302: wiring for direct motor rotation and wiring for reverse motor rotation. When wired for direct motor rotation, the motor rotates in the clockwise (CW, ↻) direction as DCP302 output increases. There are two ways of making the motor rotate in the reverse direction (counterclockwise: CCW) depending on your control requirements (e.g. cooling control):

- By switching the control operating direction on the DCP302 with the motor wired to the DCP302 for direct motor rotation as it is, or
- By wiring the motor to the DCP302 for reverse motor rotation.

The control operating direction (direct/reverse) can be switched on the DCP302. If the motor is wired to the DCP302 for direct motor rotation, the DCP302 can be easily set up for control in either direction. This makes it easier to remedy trouble that may occur during controller operation. For this reason, we recommend wiring the motor to the DCP302 for direct motor operation.

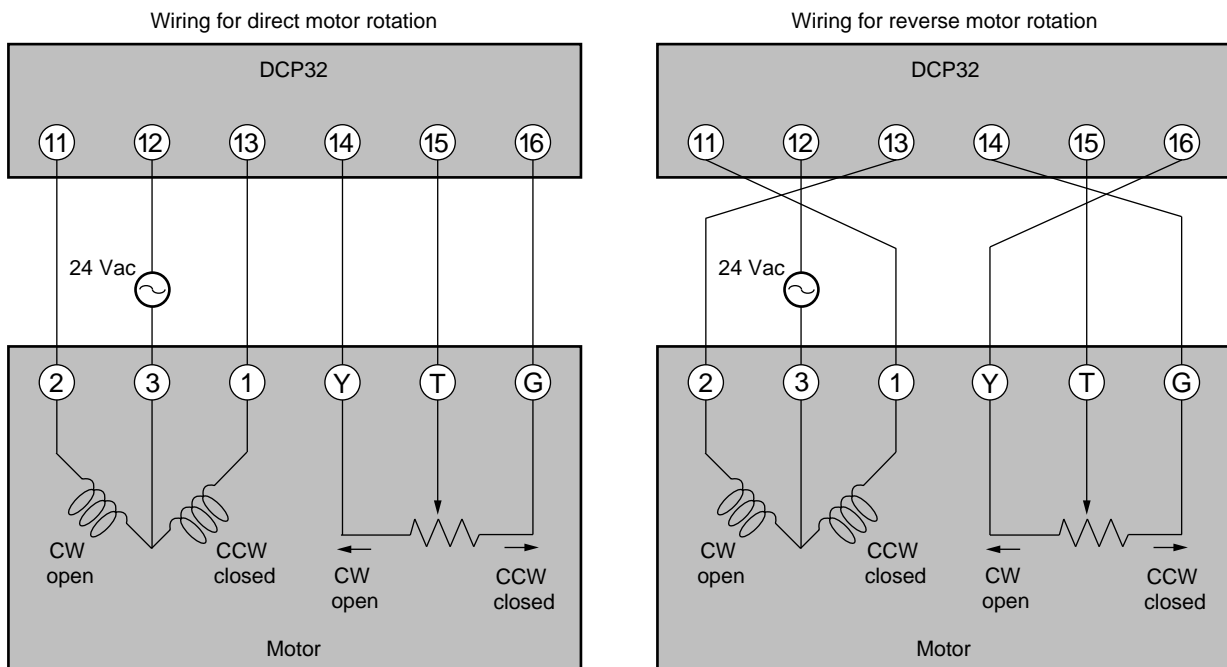

CW : Clock Wise (↻)

CCW : Counter Clock Wise (↻)

The DCP302 is also provided with a function (*AL10* to *AL12*) for detecting MFB disconnection or short-circuit if the motor has been wired to the DCP302 in the wrong way.

By this function, the DCP302 judges reverse direction wiring in the same way as direct direction wiring, and does not generate an alarm. If the setting of variable parameter *m-C* is left at the factory setting ("0"), motor operation is continued even if MFB disconnection occurs.

The following tables summarize the phenomena that occur according to how the motor and DCP302 are wired when the motor is automatically adjusted (variable parameter *m-At* setting 1 is input). Motor rotation is started from the fully closed position (motor is turned as far as possible CCW).

The values displayed in the lower display in the tables are only examples. Alarms are displayed after the motor fully closes or fully opens.

■ Normal wiring for direct motor rotation

Upper Display	Lit LEDs	Lower Display	Motor Action	Remarks
CA.CL ↓ CA.oP	OT2 OT1	Readout decreases from 1000 to 500 and stabilizes. Readout increases from 500 to 9500 and stabilizes.	CCW CW	If the motor rotates CCW when OT2 lights, motor terminals 1 and 2 are wired for direct rotation.

■ Normal wiring for reverse motor rotation

Upper Display	Lit LEDs	Lower Display	Motor Action	Remarks
CA.CL ↓ CA.oP	OT2 OT1	Readout decreases from 9500 to 500 and stabilizes. Readout increases from 500 to 9500 and stabilizes.	CW CCW	If the motor rotates CW when 1 ↔ 2 and G ↔ Y are reversed and OT2 lights, motor terminals 1 and 2 are wired for reverse rotation.

■ Alarm

Upper Display	Lit LEDs	Lower Display	Motor Action	Alarm Display	Cause
CA.CL ↓ CA.oP	OT2 OT1	Display increases and stabilizes. Display decreases and stabilizes.	CCW CW	AL12	G ↔ Y reversed
CA.CL ↓ CA.oP	OT2 OT1	Display decreases and stabilizes. Display stabilizes at 9999.	CCW CW	AL12	T ↔ G reversed
CA.CL	OT2	Display stabilizes at 9999.	CCW	AL11, AL12	T ↔ Y reversed
CA.CL ↓ CA.oP	OT2 OT1	Display increases and stabilizes. Display decreases and stabilizes.	CW CCW	AL12	1 ↔ 2 reversed
CA.CL	OT2	Display stabilizes at 9999.	CW	AL11, AL12	1 ↔ 2 reversed, T ↔ G reversed
CA.CL ↓ CA.oP	OT2 OT1	Display increases and stabilizes. Display stabilizes at 9999.	CW CCW	AL12	1 ↔ 2 reversed, T ↔ Y reversed

9 - 5 When BAT LED Blinks

Handling Precautions

Batteries left in storage for a long time discharge electricity, reducing their service life. Purchase new batteries as required.

■ BAT LED blinking

When low battery voltage is detected, the BAT LED on the console blinks. The voltage level for detection of low battery voltage is set higher than the required voltage level for holding stored setups in memory.

Accordingly, as soon as the BAT LED starts blinking, stored setups can still be held in memory. However, if the DCP302 is turned back ON after being left for a long time with its power OFF and the BAT LED blinks, setups stored to memory may be damaged.

■ Replacing the Battery

The parameter setups and program setups on the DCP302 are stored to battery backed up memory (RAM). So, stored setups are held in memory even if the DCP302 is turned OFF.

However, when battery voltage becomes low, stored setups are no longer held in memory when the DCP302 is turned OFF.

CAUTION



Before replacing the battery, be sure to turn the power OFF. Failure to do so might cause electric shock.



Do not touch internal components immediately after turning the power OFF to replace the battery. Doing so might cause burns.



- Do not insert the battery with the polarities (+, -) reversed.
- Do not use damaged (broken battery skin, leaking battery fluid) batteries.
- Do not throw batteries into fires, or charge, short-circuit, disassemble or heat batteries.
- Store batteries in low-temperature, dry locations.

Failure to observe the above cautions may cause batteries to emit heat or split, or battery fluid to leak.



Store batteries out of the reach of small children. Batteries are small and are easy to swallow. If a child swallows a battery, consult a physician immediately.



Do not throw used batteries into fires or dispose at the user site. Return used batteries to Honeywell sales/service office or your dealer.



If you touch components inside the DCP302, touch a grounded metal object to discharge any static electricity from your body. Otherwise, static electricity might damage the components.

■ Items to prepare

- Phillips head screwdriver
- New lithium battery: Model No. 81446431-001

● Replacement procedure

! Handling Precautions

- Replace with the lithium battery set (model No.: 81446431-001). The lithium battery set can be ordered from Yamatake Corporation.
- When removing or mounting the RAM board or battery connectors, do not use metallic tools. Doing so might short-circuit electrical circuits.
- While the battery is removed for battery replacement, the capacitor on the RAM board backs up the contents of memory. As this capacitor is charged, make sure that the DCP302 is left ON for at least ten minutes before replacing the battery. Insert the new battery on the RAM board within 24 hours of turning the DCP302 OFF.

When the BAT LED starts blinking, follow the procedure below to replace the battery.

- ① Leave the DCP302 turned ON for at least ten minutes.
- ② Turn the power OFF.
- ③ Remove the key cover from the console, and fully loosen the lock screw under the ENT key with a Phillips screwdriver.
 - » The body comes out towards you.

Comes out towards you.

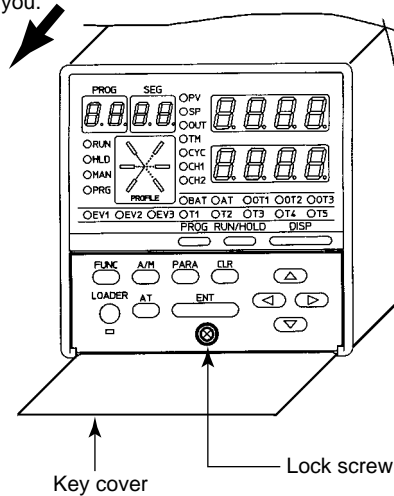

- ④ Before handling components inside the DCP302, touch a grounded metal part to remove any static electricity from your body.
- ⑤ Pull the body out towards you to remove from the case.
 - » You should be able to see the button-shaped battery on the left as you face the body.

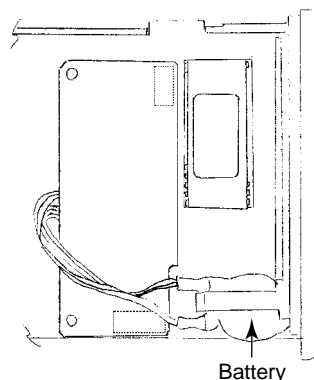

- ⑥ Place the body on a desk or flat surface so that the side on which the battery is installed is facing up.
- ⑦ Remove the battery from its gray holder.
- ⑧ Remove the RAM board (approx. 3 cm x 8 cm) with the battery still connected to the board.

The RAM board is connected to the base board by two connectors.

! Handling Precautions

When placing the RAM board on the desk, make sure that the solder surface of the board is face down. If the component mounting surface is placed face down, the components may become damaged.

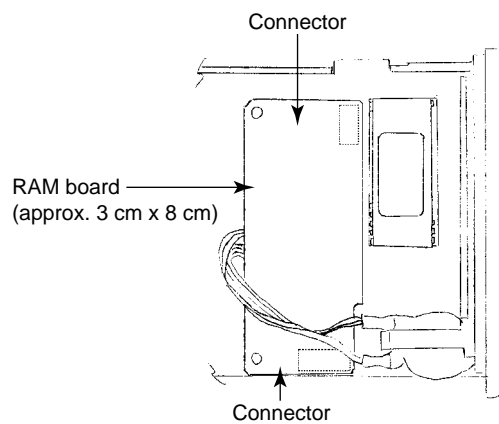

- ⑨ Remove the battery connector from the RAM board.

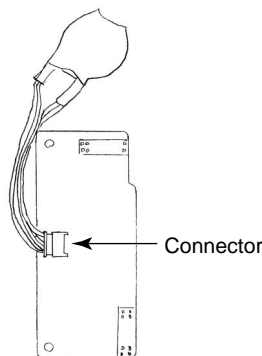

- ⑩ Connect the connector of the new battery to the RAM board making sure that it is inserted in the correct direction.
- ⑪ Mount the RAM Board making sure that it is mounted in the correct direction. Do not insert the battery cable under the RAM board.

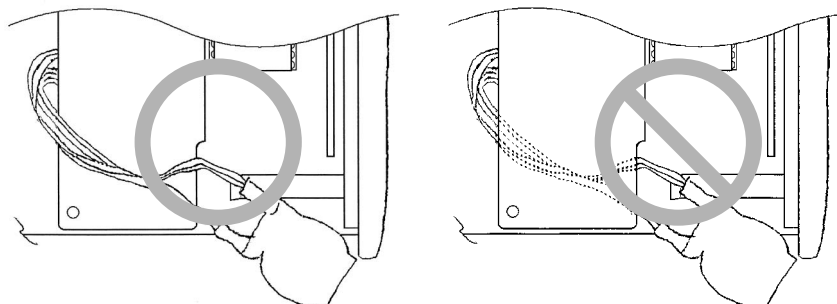

- ⑫ Fit the battery into the gray holder so that the battery cable is above the RAM board.

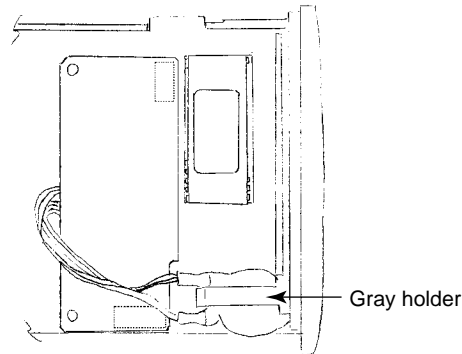

- ⑬ Insert the body into the case.
Do not exert excessive force if the body cannot easily fit into the case. Also, make sure that the boards mounted on the body are not loose or twisted.
- ⑭ Tighten the lock screw while slightly pushing in the DCP302's console. Take care not to overtighten the screw.
- ⑮ Turn the DCP302 ON, and make sure that the BAT LED is out.

 **Note**

- The following serves as a general guideline for when to replace the battery:
About 3 years when using the DCP302 under standard operating conditions (operating temperature: $23\pm 2^{\circ}\text{C}$) with the DCP302 power ON
About 10 years when using the DCP302 under standard operating conditions (operating temperature: $23\pm 2^{\circ}\text{C}$) with the DCP302 power OFF
Using the DCP302 in a higher operating temperature will shorten its service life.
- Setups are held in memory with the DCP302 power ON even if the BAT LED is blinking.
- The DCP302 operates in one of two ways when memory contents are damaged.
 - ① “*g.rESf*” is displayed when the DCP302 is turned ON and regular operation is not started.
(If this happens, press the ENT key to execute a general reset. This restores parameter setups to factory settings and clears the program setup.)
 - ② Regular operation is started when the DCP302 is turned ON, and one of alarm codes *AL96* and *AL97* is displayed.

Chapter 10. SPECIFICATIONS

10 - 1 Specifications

	Item	Specification
Program	Number of programs	19
	Number of segments	30 per program
	Segment setting system	RAMP-X system: Set by set points (SP1, SP2) and time.
	Segment time	0 to 99 hours 59 minutes, or 0 to 99 minutes 59 seconds (time unit selectable)
	Basic time accuracy	±0.01% (0.1 second delay when segment time setting is 0)
	Events (3)	Sets operating point.
	Time events (5)	Sets ON and OFF times.
	PID set No. (2CH)	Sets 0 to 8 (Set 0 for continuation of previous segment) (Set 0 to 4 on heat/cool models.)
	G.Soak (2CH)	Sets G.Soak width 0 to 1000U.
	PV start	Sets program ON/OFF and channel.
	Cycle	Sets program count 0 to 9999.
	Pattern link	Sets program No.0 to 19 (0: no link)
	Tag	Sets 8 alphanumeric for each program (not displayed on controller)
Input 1	Input type	Thermocouple, resistance temperature detector, DC voltage, DC current multi-range (See pages 2-8 and 2-9.)
	Input readout accuracy	±0.1%FS±1U (varies according to standard conditions, display value conversion and range) <ul style="list-style-type: none"> • At -100°C max. of K and T thermocouples: ±1°C±1U • At 260°C max. of B thermocouple: ±4.0%FS±1U <ul style="list-style-type: none"> At 260 to 800°C: ±0.4%FS±1U At 800 to 1800°C: ±0.2%FS±1U • At 100°C max. of R and S thermocouples: ±0.2%FS±1U <ul style="list-style-type: none"> At 100 to 1600°C: ±0.15%FS±1U • At 300°C max. of PR40-20 thermocouple: ±2.5%FS±1U <ul style="list-style-type: none"> At 300 to 800°C: ±1.5%FS±1U At 800 to 1900°C: ±0.5%FS±1U • Golden iron chromel thermocouple: ±1.5K±1U • F01, F33, F38, P01, P33 and P38 ranges by resistance thermometer detector input: ±0.15%±1U • At 0 to 10 mV range: ±0.15%FS±1U • At -100°C max. of DIN U thermocouple: ±2°C±1U <ul style="list-style-type: none"> At -100 to 0°C: ±1°C±1U • At -100°C max. of DIN L thermocouple: ±1.5°C±1U
	Input sampling cycle	0.1 seconds
	Input bias current	Thermocouple, DC voltage input: ±1.3 μA max. (at peak value, under standard conditions) At 1 V min. range: -3 μA max.
	Input impedance	DC current input: 50 Ω±10% (under operating conditions)
	Measuring current	RTD input: 1.04 mA ±0.02 mA, current flow from terminal A (under operating conditions)
	Influence of wiring resistance	Thermocouple, DC voltage input: Changes in readout value at wiring resistance of 250 Ω at both ends are as follows by input conversion: <ul style="list-style-type: none"> • 0 to 10 mV, -10 to +10 mV: Within 35 μV • 0 to 100 mV: Within 60 μV • Other: Within 750 μV RTD input: ±0.01%FS/Ω max. in wiring resistance range 0 to 10 Ω Range of F01, F33, F38, P01, P33 and P38: ±0.02%FS/Ω max.
	RTD input allowable wiring resistance	<ul style="list-style-type: none"> • Allowable wiring resistance is 85 Ω max. (including Zener barrier resistance. When Zener barrier is used, this applies only to ranges other than F01, F33, F38, P01, P33 and P38. Note that site adjustment is required.) • Allowing wiring resistance is 10 Ω max. (This applies to ranges F01, F33, F38, P01, P33 and P38. Note that the Zener barrier cannot be used.)
	Allowable parallel resistance	Thermocouple disconnection detection allowable parallel resistance: 1 MΩ min.

Item		Specification
Input 1	Max. allowable input	Thermocouple, dc voltage input: -5 to +15 Vdc dc current input: 50 mA dc, 2.5 Vdc
	Burnout	Upscale and downscale can be internally selected. (dc current input and dc voltage input ranges of 1 V or more are only downscaled.)
	Over-range detection threshold	110%FS min.: Upscaled -10%FS max.: Downscaled (Note that F50 range is not downscaled. Lower readout limit of B18 range is 20°C.)
	Cold junction compensation accuracy	±0.5°C (under standard conditions)
	Influence of ambient temperature on cold junction compensation	±0.2°C (in range 0 to 50°C)
	Cold junction compensation system	Internal/external (0°C only) compensation selectable
	Scaling	-1999 to +9999U (settable by dc voltage and dc current. Reverse scaling and decimal point repositioning possible)
	Square root extraction	Dropout 0.1 to 10.0%, Possible by dc current and voltage ranges
	Linearization table approximation	12 (both line ends fixed, 11 points variable)
	Input bias	-1000 to +1000U variable
	Digital filter	0.0 to 120.0 seconds variable (filter OFF at 0.0)
Input 2	Input type	Thermocouple, resistance temperature detector, dc voltage, multi-range (See page 2-10.)
	Input readout accuracy	±0.2%FS±1U (varies according to standard conditions, display value conversion)
	Input sampling cycle	0.1 seconds
	Input bias current	Thermocouple: ±2.0 μA max. (under standard conditions) dc voltage input: ±5 μA max. (under standard conditions)
	Measuring current	RTD input: 0.64 mA ±0.02 mA, current flow from terminal A (under operating conditions)
	Influence of wiring resistance	Thermocouple, dc voltage input: Changes in readout value at wiring resistance of 250 Ω at both ends are as follows by input conversion: • RTD: Within 300 μV • DC voltage: Within 750 μV RTD input: ±0.01%FS/Ω max. in wiring resistance range 0 to 10 Ω Range of F01 and P01: ±0.02%FS/Ω max.
	RTD input allowable wiring resistance	• Allowable wiring resistance is 85 Ω max. (including Zener barrier resistance. When Zener barrier is used, this applies only to ranges other than F36 and P36. Note that site adjustment is required.) • Allowing wiring resistance is 10 Ω max. (This applies to ranges F01 and P01. Note that the Zener barrier cannot be used.)
	Allowable parallel resistance	Thermocouple disconnection detection allowable parallel resistance: 1 MΩ min.
	Max. allowable input	Thermocouple: -0.3 to +5 Vdc dc voltage input: -1 to +11 Vdc
	Burnout	Thermocouple, RTD: Upscaled dc voltage input: Downscaled
	Over-range detection threshold	110%FS min.: Upscaled -10%FS max.: Downscaled (Note that the range of L07 is downscaled at -1%FS or less.)
	Cold junction compensation accuracy	±0.7°C (under standard conditions)
	Influence of ambient temperature on cold junction compensation	±0.2°C (in range 0 to 50°C)
	Cold junction compensation system	Internal/external (0°C only) compensation selectable

Item		Specification
Input 2	Scaling	-1999 to +9999U (settable by dc voltage range. Reverse scaling and decimal point repositioning possible)
	Square root extraction	Dropout 0.1 to 10.0%, Possible by DC voltage range
	Linearization table approximation	12 (both line ends fixed, 11 points variable)
	Input bias	-1000 to +1000U variable
	Digital filter	0.0 to 120.0 seconds variable (filter OFF at 0.0)
External Switch (RSW) Input	Number of inputs	12
	Types of connectable outputs	Dry contacts (relay contact) and open-collector (current sink to ground)
	Terminal voltage (open)	10.4 to 12.6 V (under operating conditions) across common terminal (terminal ②) and each input terminal
	Terminal current (short-circuit)	5.0 mA +6.6 mA across each terminal (under operating conditions)
	Allowable contact resistance (dry contact)	ON: 700 Ω max. (under operating conditions) OFF: 10 kΩ min. (under operating conditions)
	Residual current (open-collector ON)	3 V max. (under operating conditions)
	Leakage current (open-collector OFF)	0.1 mA max. (under operating conditions)
	Parallel connection to other instruments	Can be connected to DCP301/302 series.
	Assignments (fixed)	RUN, HOLD, RESET, ADV, program No.
	Assignments (variable)	FAST, PV start, AT, AUTO/MANUAL, G.Soak cancel, reverse/direct action
	Input sampling cycle	0.1 seconds
	ON detection min. hold time	0.2 seconds (program No. 0.4 seconds)
Indication /Programmer	Upper display	Green 4-digit, 7-segment LED This normally displays PV values. Item codes are displayed in parameter setup.
	Lower display	Orange 4-digit, 7-segment LED This normally displays SP values and output value. Setting values are displayed in parameter setup.
	Program No. display	Green 2-digit, 7-segment LED This normally displays program No.
	Segment No. display	Green 2-digit, 7-segment LED This normally displays segment No. Item Nos. are displayed in parameter setup, and alarm No. is displayed when alarm occurs.
	Profile display	6 orange LEDs Displays program pattern rise, soak and fall tendencies.
	Status displays	24 round LEDs Modes: RUN, HLD, MAN, PRG (green) Display details: PV, SP, OUT, TM, CYC, CH1, CH2 (green) Battery voltage: BAT (red) (blinks at low voltage) Status: AT, OT1, OT2, OT3 (orange) Events: EV1, EV2, EV3, T1, T2, T3, T4, T5 (orange)
	Operation keys	13 rubber keys
	Loader connector port	1 (dedicated cable with stereo miniplugs)
Mode	Program operation mode	READY: Ready to run program (control stop/program No. selectable)
		RUN: Program run HOLD: Program hold FAST: Program fast-forward END: Program end AUTO: Automatic operation MANUAL: Manual operation (output controlled on console)

Item		Specification	
Mode	Constant-value operation mode	READY:	Ready to run program (control stop)
		RUN:	Program running
		AUTO:	Automatic operation
		MANUAL:	Manual operation (output controlled on console)
Control	PID control	Proportional band (P)	0.1 to 999.9%
		Rate time (I)	0 to 3600 seconds, PD control if set to 0
		Reset time (D)	0 to 1200 seconds, PI control if set to 0
		MV limit	Lower limit: -10.0 to upper limit % Upper limit: Lower limit to +110.0%
		Manual reset	0.0 to 100.0%
		Number of PID sets	8 sets for program operation + 1 set for constant-value operation
		PID set selection	Segment designation/automatic zone selection can be switched by program operation
		MV change limit	0.1 to 10.0%/0.01 seconds, no limit by 0.0
		Auto-tuning	Automatic setting of PID value by limit cycle system + Neuro & Fuzzy (2 degrees of freedom PID) and Smart systems (not possible on heat/cool channel)
		Position-proportional dead zone	0.5 to 25.0% (settable on 2G output model)
		Heat/cool dead zone	-100.0 to +50.0% (settable on 3D and 5K output models)
		3-position control	Deviation lower limit
	Deviation upper limit		(settable when 3-position control is selected on 3D output models)
	Deviation lower limit hysteresis		
	Deviation upper limit hysteresis		
	Reverse/direct action switching	Switchable	(output other than heat/cool)
	Programmer function	Switching	MV output can be switched to SP output (current output).
		Scaling	Supported
		Output resolution	1/10000
	Auxiliary output	Type	PV, SP, deviation, MV, MFB
Scaling		Supported	
Output resolution		1/10000	
Output	0D output 1 3D outputs 1, 2, 3	Relay contact output	Contact type: 1a1b Contact rating: 5A (30 Vdc, resistive load) 5A (120 Vac, resistive load) 4A (240 Vac, resistive load) Allowable contact voltage: 250 Vac, resistive load 125 Vdc, resistive load Max. switching power: 150 W, resistive load 960 VA, resistive load Life: 100,000 operations (resistive load at contact rating, frequency: 30 operations/minute) Min. switching voltage: 5 V Min. switching current: 100 mA Output resolution: 1/1000 Time-proportional cycle: 5 to 120 seconds

Item		Specification	
Output	2G output 1	M/M drive relay	<p>Contact type: 1a (2 circuits)</p> <p>Contact rating: 2.5A (30 Vdc, L/R=0.7 ms) 4A (120 Vac, cosϕ=0.4) 2A (240 Vac, cosϕ=0.4)</p> <p>Allowable contact voltage: 250 Vac, cosϕ=0.4 125 Vdc, L/R=0.7 ms</p> <p>Max. switching power: 75 W (L/R=0.7 ms) 480 VA (cosϕ=0.4)</p> <p>Life: 100,000 operations (cosϕ=0.4 at contact rating, frequency: 30 operations/minute)</p> <p>Min. switching voltage: 5 V</p> <p>Min. switching current: 100 mA</p> <p>MFB (motor feedback) input range: 100 to 2500 Ω</p> <p>Control at MFB (motor feedback) disconnection: ON/OFF for continuation of operation according to MFB estimated position can be selected.</p>
	5G outputs 1, 2 5K outputs 1, 2, 3 Auxiliary output	Current output	<p>Output current: 4 to 20 mA dc/0 to 20 mA dc</p> <p>Allowable load resistance: 600 Ω max. (under operating conditions)</p> <p>Output accuracy: \pm0.1%FS max. (under standard conditions) Note that output accuracy becomes \pm0.5%FS when 0 to 20 mA output is 5% or less.</p> <p>Output resolution: 1/10000</p> <p>Inrush current: 25 mA max for 50 ms max. (at 250 Ω load)</p> <p>Max. output current: 22.0 mA dc</p> <p>Min. output current: 0.0 mA dc</p> <p>Output updating cycle: 0.1 seconds</p> <p>Open terminal voltage: 25 V max. (output 1) 18 V max. (output 2, output 3, auxiliary output)</p>
	5G outputs 1, 2 5K outputs 1, 2, 3 (when current output is switched to voltage output)	Voltage output	<p>Allowable load resistance: 600 Ω max. (under operating conditions)</p> <p>Inrush current: 25 mA max for 50 ms max. (at 250 Ω load)</p> <p>Load current adjustment: 2 to 22 mA variable</p> <p>Open terminal voltage: 25 V max. (output 1) 18 V max. (output 2, output 3)</p> <p>OFF leakage current: 100 μA max.</p> <p>Output response time: At ON-OFF 600 Ω load: 0.5 ms max. At OFF-ON 600 Ω load: 1.0 ms max.</p> <p>Output resolution: 1/1000</p> <p>Time-proportional cycle: 1 to 60 seconds variable</p>
Event/ Time Event Output	Events 1, 2	Relay contact output	<p>Contact type: 1a</p> <p>Contact rating: 1A (240 Vac/30 Vdc, resistive load)</p> <p>Life: 100,000 operations (at rating)</p> <p>Min. switching voltage, current: 10 V, 10 mA</p>
	Event 3	Relay contact output	<p>Contact type: 1a1b</p> <p>Contact rating: 2A (240 Vac/30 Vdc, resistive load)</p> <p>Life: 100,000 operations (at rating)</p> <p>Min. switching voltage, current: 10 V, 10 mA</p>
	Time events 1 to 5	Open-collector output	<p>External supply voltage: 10 to 29 Vdc</p> <p>Max. load current: 70 mA/load</p> <p>OFF leakage current: 0.1 mA max.</p> <p>ON residual voltage: 1.6 V max.</p>

Item		Specification	
Event/ Time Event Output	Event 1 to 3 settings	Event type	PV type events: PV, deviation, absolute value deviation, SP, MV, MFB Controller status events: RUN+HOLD+FAST+END, READY, RUN, HOLD, FAST, END, G.Soak standby, MANUAL, auto-tuning executing, constant-value operation, MFB estimated position control, sum of all alarms, PV range alarm, controller alarms, low battery voltage, setting on console, ADV Time events
		Event standby	ON/OFF selectable
		Event hysteresis	0 to 200U (event types PV, deviation, absolute value deviation or SP) 0.0 to 20.0% (event types MV or MFB)
		Event ON delay	0 to 3600 seconds
	Time event 1 to 5 settings	Time event type	Time events, segment No. events
Communi- cations	Communications system	Communications standard	RS-485
		Network	Multidrop (DCP302 provided with only slave node functionality) 1 to 31 units max.
		Data flow	Half duplex
		Synchronization	Start-stop synchronization
	Interface system	Transmission system	Balanced (differential)
		Data line	Bit serial
		Signal line	5 transmit/receive lines (3-wire connection also possible)
		Transmission speed	4800, 9600 bps
		Transmission distance	500 m max. (total)
		Other	Conforming to RS-485
	Display characters	Char. bit count	11 bits/character
		Format	1 start bit, even parity, 1 stop bit; or 1 start bit, no parity, and 2 stop bits
		Data length	8 bits
	Isolation	All inputs and outputs are completely isolated.	
	RS-485 communications can be performed by connecting to a computer equipped with an RS-485 interface.		
General Specifi- cations	Memory backup	Memory Battery backed-up RAM	
		Battery life	Controller power OFF Approx. 3 years under standard conditions Controller power ON Approx. 10 years under standard conditions
	Rated power voltage	90 to 264 Vac, 50/60 Hz	
	Power consumption	30 VA max.	
Power ON rush current	15 A max., 10 ms (under operating conditions)		
	<p>⚠ Handling Precautions</p> <p>When starting up a number of DCP302s simultaneously, ensure ample power is supplied or stagger startup times. Otherwise, the controllers may not start normally due to inrush current induced-voltage drop. Voltage must stabilize within two seconds after power ON.</p>		

Item		Specification	
Event/ General Specifi- cations	Power ON operation	Reset time: 15 sec max. (time until normal operation possible under normal operating conditions)	
	Allowable transient power loss	20 ms max. (under operating conditions)	
	Insulation resistance	Min. 20 MΩ across power terminals 1 or 2 and ground terminal 3 (using a 500 Vdc megger)	
	Dielectric strength	1500 Vac 50/60 Hz for 1 minute across power terminal and ground terminal 1500 Vac 50/60 Hz for 1 minute across relay output and ground terminal 500 Vac 50/60 Hz for 1 minute across non-power terminal and ground terminal 500 Vac 50/60 Hz for 1 minute across isolated terminals	
	Standard conditions	Ambient temperature	23 ±2°C
		Ambient humidity	60 ±5%RH
		Rated power voltage	105 Vac ±1%
		Power frequency	50 ±1 Hz or 60 ±1 Hz
		Vibration resistance	0 m/s ²
		Impact resistance	0 m/s ²
		Mounting angle	Reference plane (vertical) ±3°
	Operating conditions	Ambient temperature range	0 to 50°C (temperature at case bottom when closely mounted)
		Ambient humidity range	10 to 90% RH (no condensation)
		Rated power voltage	90 to 264 Vac
		Power frequency	50 ±2 Hz or 60 ±2 Hz
		Vibration resistance	0 to 1.96 m/s ²
		Impact resistance	0 to 9.80 m/s ²
		Mounting angle	Reference plane (vertical) ±10°
	Installation types	Permanent connection type unit, indoor mounting, panel mounting	
	Applicable standards	EN61010-1, EN50081-2, EN50082-2 (CE Marking declaration)	
	Installation category	Category II (IEC664-1, EN61010-1)	
	Pollution degree	2	
	Fuse	Rating	IEC127
		Cutoff speed	Delayed operation type (T)
		Rated voltage	250 V
		Rated current	1 A
	Transport/storage conditions	Ambient temperature	-20 to +70°C
		Ambient humidity	10 to +95%RH (no condensation)
		Vibration resistance	0 to 4.90 m/s ² (10 to 60 Hz for 2 hours each in X, Y and Z directions)
		Impact resistance	0 to 490 m/s ² (3 times vertically)
Package drop test		Drop height: 60 cm (1 corner, 3 edges and 6 planes; free fall)	
Terminal screw	M3.5 self-tapping screw		
Terminal screws tightening torque	0.78 to 0.98 N•m		
Mask/case materials	Mask: Multilon Case: Polycarbonate		
Mask/case color	Mask: Dark gray (Munsell 5Y3.5/1) Case: Light gray (Munsell 2.5Y7.5/1)		
Installation	Specially designed mounting bracket		
Weight	Approx. 900 g		

■ Accessories/option list

	Item	Model No.	Q'ty
Standard accessories	Unit indicating label	N-3132	1
	Mounting bracket	81405411-001	1 set (2 brackets)
Options (sold separately)	Hard dust-proof cover set	81446083-001	—
	Soft dust-proof cover set	81446087-001	—
	Terminal cover set	81446084-001	—
	Lithium battery set	81446431-001	—
Related manuals	User's Manual	EN11-6215	—

10 - 2 External Dimensions

■ DCP302

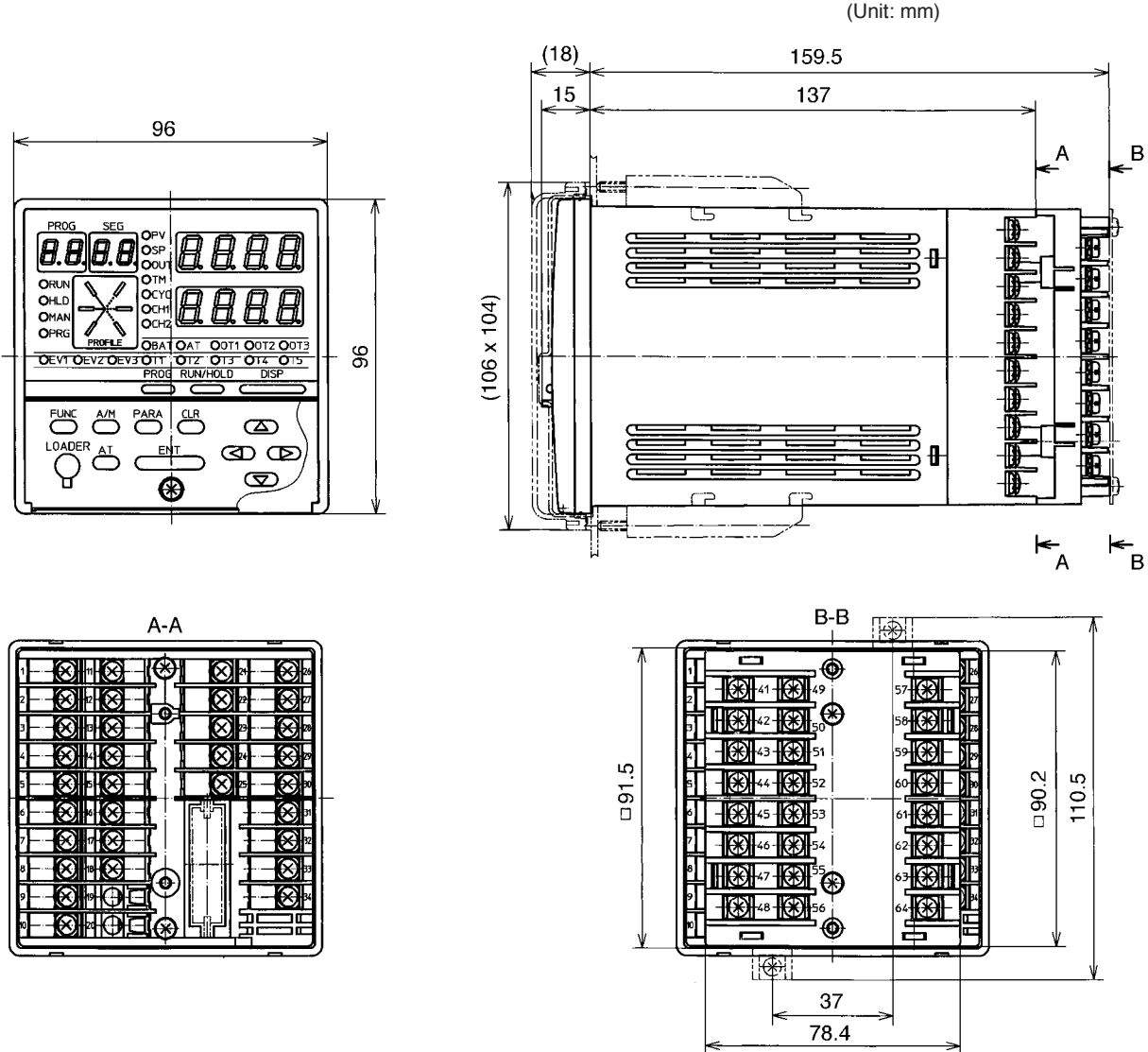

■ Soft dust-proof cover set (sold separately)
(transparent silicon rubber)

Model No.: 81446087-001

(Unit: mm)

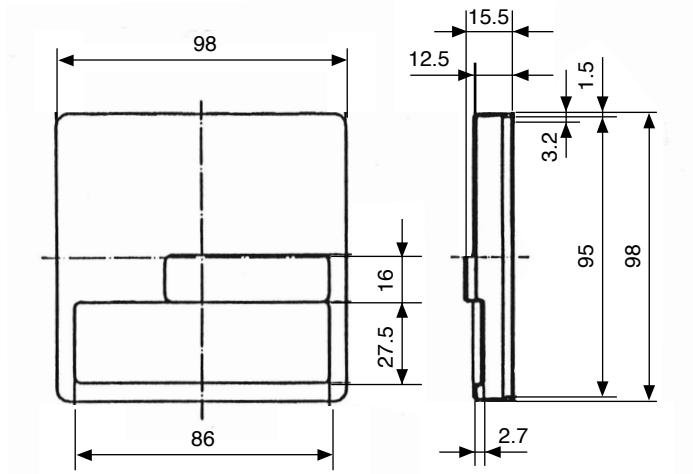

■ Hard dust-proof cover set (sold separately)
(transparent polycarbonate)

Model No.: 81446083-001

(Unit: mm)

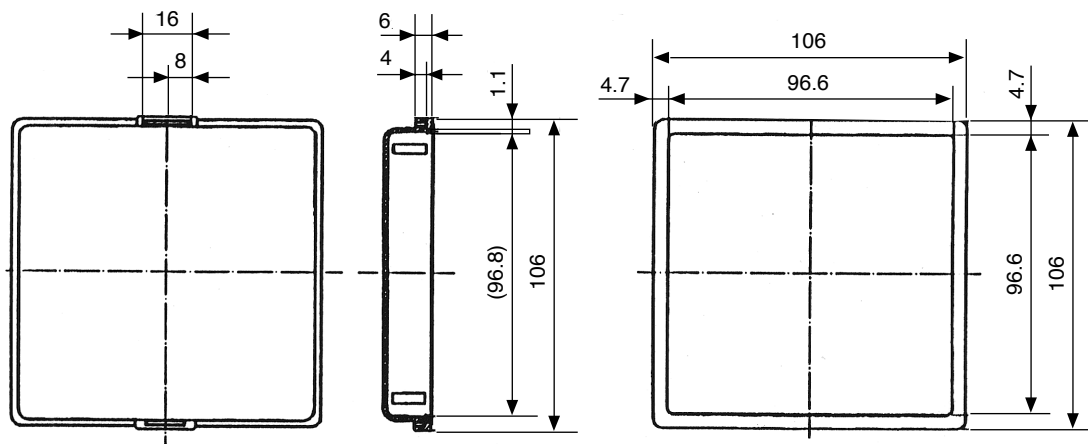

■ Terminal cover set (sold separately)
(gray non-flammable, heat-resistant PVC)

Model No.: 81446084-001

(Unit: mm)

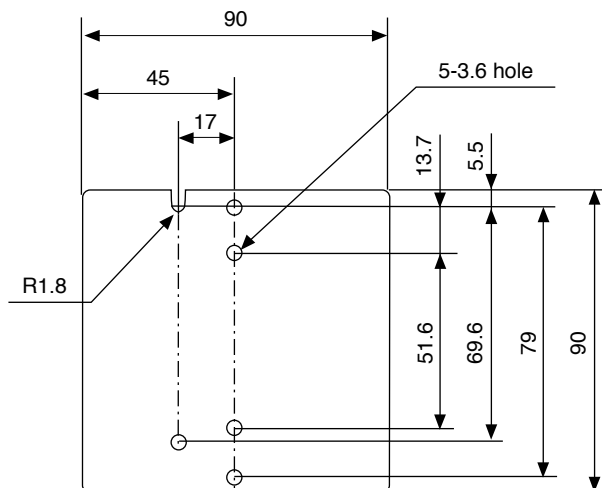

Can be attached to either of standard or add-on terminal base.

Chapter 11. CALIBRATION

This chapter covers the field calibrations procedures for the inputs, outputs and various functions of the DCP301 and DCP302 controller after shipment from the factory. When calibration is made in the field, the original factory data is erased, and so the specified input/output accuracies of the controller cannot be assured. This manual is for users who are conversant with DCP301 and DCP302 use and operation.

■ Precautions before calibration

Apply power and allow the controller to warm up for 2 hours before you calibrate the DCP301 and DCP302. Confirm that the test equipment needed for calibration has stabilized.

Factory calibration has been made at a stable temperature of 23.0°C ($\pm 2^\circ\text{C}$). Calibrate the DCP301 and DCP302 in this range, and where there are no significant fluctuations in air temperature.

If calibration equipment of a lower grade than specified below is used, calibration results may be unsatisfactory.

■ Equipment needed

- (1) Standard input source with $\pm 0.02\%$ accuracy (having more than 5 effective digits and capable of generating both voltage and current outputs)
- (2) Decade resistance box with $\pm 0.02\%$ accuracy (having a range of 10 to 500 Ω with a resolution of more than 0.01 Ω)
- (3) Digital ammeter with $\pm 0.02\%$ accuracy (measurable in the range of 4 to 20mA with assured resolution of more than 0.01mA)
- (4) Thermometer with $\pm 0.1^\circ\text{C}$ accuracy (resolution of more than 0.1 $^\circ\text{C}$)

11-1 Quick Reference Table for Calibration Items

DCP301 and DCP302 controllers are numbered using the following format. Format items may require different calibration procedures, as shown in Table 11-1.

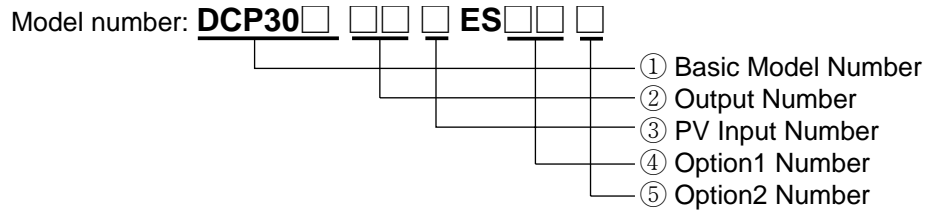

Table 11-1. Calibration Items for Each Model

Calibration & Test Item	Model	Basic Model: DCP302	Option2: 1, 2	Output and Option Model Number					
				Output:5G		Output:0D		Output:2G, 3D	Output:5K
				Option1:00	Option1:01	Option1:00	Option1:01	Option1:00	Option1:00
0 Function Test	Key Test	<input type="checkbox"/>							
	Indicator Test	<input type="checkbox"/>							
	DI Test(1 to 4)	<input type="checkbox"/>							
	DI Test(5 to 12)		<input type="checkbox"/>						
	DO Control Output Ch1 Test			<input type="checkbox"/>	<input type="checkbox"/>	<input type="checkbox"/>	<input type="checkbox"/>	<input type="checkbox"/>	<input type="checkbox"/>
	DO Control Output Ch2 Test			<input type="checkbox"/>	<input type="checkbox"/>	<input type="checkbox"/>	<input type="checkbox"/>	<input type="checkbox"/>	<input type="checkbox"/>
	DO Control Output Ch3 Test							<input type="checkbox"/>	<input type="checkbox"/>
	DO Test(1 to 3:Event)	<input type="checkbox"/>							
DO Test(4 to 8:Time Event)		<input type="checkbox"/>							
1 PV Input Calibration	Gain No.0 to 12	<input type="checkbox"/>							
	Gain No.16 to 20	<input type="checkbox"/>							
2 CJ Sensor Calibration		<input type="checkbox"/>							
4 Current Output Calibration	Output Ch1			<input type="checkbox"/>	<input type="checkbox"/>				<input type="checkbox"/>
	Output Ch2			<input type="checkbox"/>	<input type="checkbox"/>	<input type="checkbox"/>	<input type="checkbox"/>		<input type="checkbox"/>
	Output Ch3				<input type="checkbox"/>		<input type="checkbox"/>	<input type="checkbox"/>	<input type="checkbox"/>

Table 11-2. Item and Sub Item Table for Calibration

Item	Sub Item	Description	Upper Display Shows	Lower Display Shows
0	0	Item change code	<i>0.0.0.0.</i> etc.	<i>AdJS</i>
	1	Key test		
	2	Display test		
	3	Digital input test		
	4	Output test (control)		
	5	Output test (digital output)		
1	0	Item change code	<i>1.0.1.1.</i>	
	1	Gain No.		
	2	PV input 0%		
	3	PV input 100%		
2	0	Item change code	<i>2.0.2.2.</i>	<div style="border: 1px solid black; width: 20px; height: 20px; display: inline-block; vertical-align: middle;"></div> Previous adjustment value
	1	CJ input 0%		
	2	CJ count		
	3	CJ temperature		
4	0	Item change code	<i>4.0.4.4.</i>	<div style="border: 1px solid black; width: 20px; height: 20px; display: inline-block; vertical-align: middle;"></div> Previous adjustment value
	1	OUT ch1 4mA output		
	2	OUT ch1 20mA output		
	3	OUT ch2 4mA output		
	4	OUT ch2 20mA output		
	5	OUT ch3 4mA output		
	6	OUT ch3 20mA output		

- Notes:**
1. Items No. is shown on the PROG display.
 2. Sub item No. is shown on the SEG display.
 3. Item 0: Function check item
 4. Items 1, 2 and 6 : Calibration items

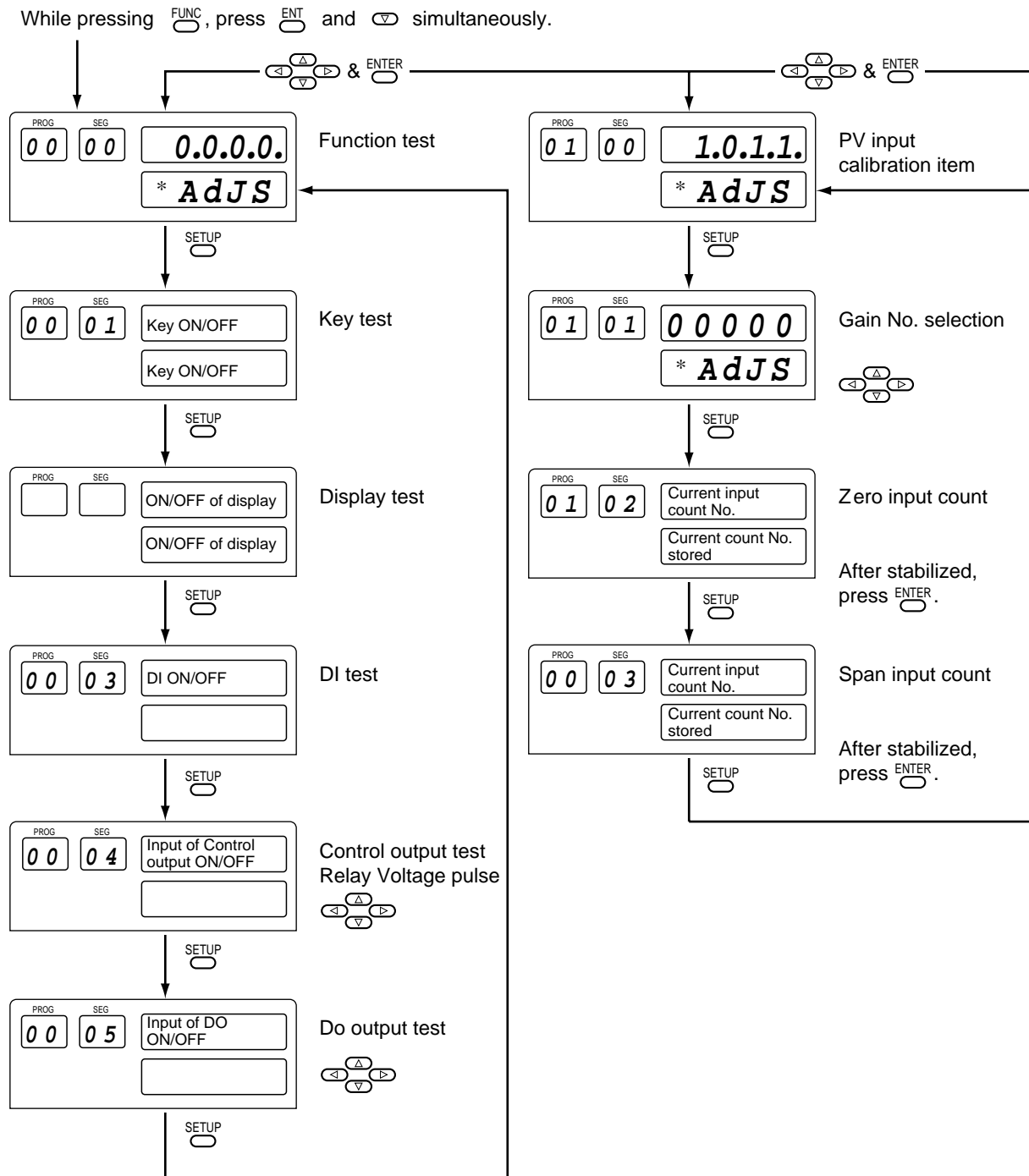

- Notes:** *; 1. This display shows the digits shown in the previous indication.
 2. If wrong key operation is made when moving from one to another item, the display is returned to the initial status of calibration mode. But, the mode is still in the calibration mode.

Figure 11-1. Calibration Flowchart (1/2)

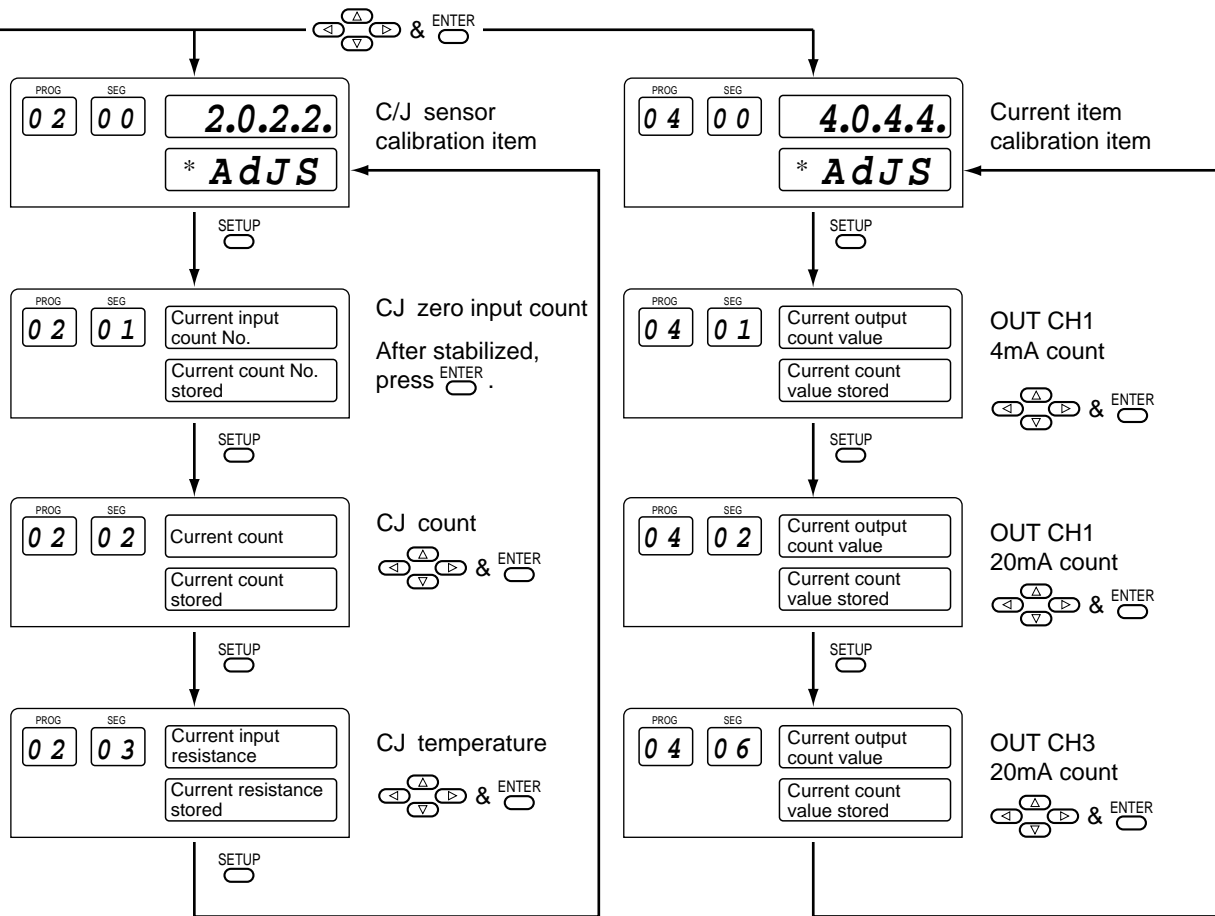

Figure 11-1. Calibration Flowchart (2/2)

11-2 Calibration Procedures

■ Enter calibration mode

1. Release keylock. (**PARA LoC=0** and **PrtC=0**)
2. Press **DISP key** to permit ordinary indication condition.
Change to READY (**RUN** and **HLD** are off) and AUTO (**MAN** off) modes.
The following LEDs will illuminate after the above operations.
RUN LED is OFF
HLD LED is OFF
MAN LED is OFF

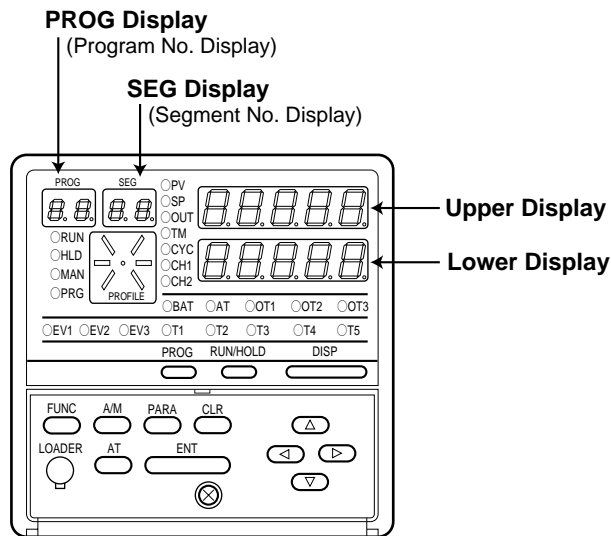

Figure 11-2.

3. To enter calibration mode, hold down the **FUNC key**, and press **ENT key** and **↓ key** simultaneously.
The display will show the symbols described in Figure 11-3. If the indication is different, repeat the above procedure after pushing **DISP key** to refresh the display.
4. To select individual calibration items, press **↑, ↓, ←, or → keys** to select the item by scrolling, then **PARA key**, and **ENT key**.
The order of calibration items is described in Table 11-2.

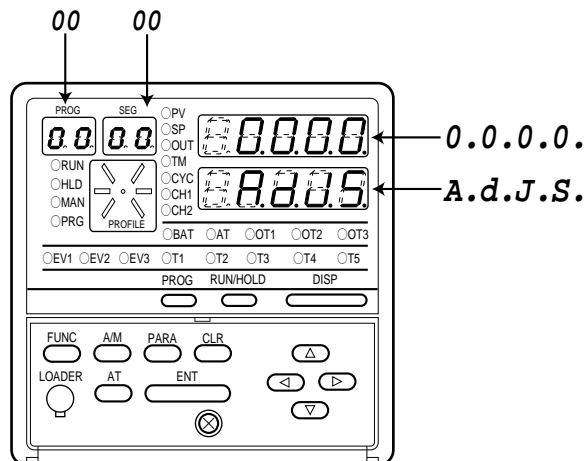

Figure 11-3.

■ Function test











Press \uparrow , \downarrow , \leftarrow , or \rightarrow **keys** to show (0.0.0.0) on upper display, then press **ENT key**.

● Key test (00-01)

Press **PARA key** until the PROG/SEG display shows (00-01).

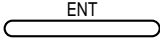
When you press each key, the data appears in the upper display (shown in Table 11-3).

Table 11-3. Upper Display

Key	Data	Key	Data
PROG 	0.0.4.0.	RUN/HOLD 	4.0.0.0.
FUNC 	0.0.2.0.	A/M 	0.0.0.1.
CLR 	0.0.0.4.	AT 	0.1.0.0.
	0.0.0.8.	ENT 	0.2.0.0.
	0.8.0.0.		0.0.1.0.
			1.0.0.0.

! HANDLING PRECAUTIONS

1. When you press **DISP key**, calibration mode will be exited.
2. When you press **PARA key**, the next calibration menu will be entered (Display test).

●Display test (00-02)

Press **PARA key** until the display test starts.
 Then, each 7-segment LED, LED indicators and LCD illuminates at every 0.5 sec.
 This is to check if each LED/LCD illuminates.

●Digital input test (00-03)

Press **PARA key** until the PROG/SEG display shows (00-03).
 When you turn on or off each remote switch, the upper display will show the data described in Table 11-4.

Table 11-4. DI

Upper Display \ DI Terminal Number	⑳	㉑	㉒	㉓	㉔	㉕	㉖	㉗	㉘	㉙	㉚	㉛	㉜
	↕	↕	↕	↕	↕	↕	↕	↕	↕	↕	↕	↕	↕
	㉝	㉝	㉝	㉝	㉝	㉝	㉝	㉝	㉝	㉝	㉝	㉝	㉝
0.0.0.0.	—	—	—	—	—	—	—	—	—	—	—	—	—
0.0.0.1.	ON	—	—	—	—	—	—	—	—	—	—	—	—
0.0.0.2.	—	ON	—	—	—	—	—	—	—	—	—	—	—
0.0.0.4.	—	—	ON	—	—	—	—	—	—	—	—	—	—
0.0.0.8.	—	—	—	ON	—	—	—	—	—	—	—	—	—
0.0.1.0.	—	—	—	—	ON	—	—	—	—	—	—	—	—
0.0.2.0.	—	—	—	—	—	ON	—	—	—	—	—	—	—
0.0.4.0.	—	—	—	—	—	—	ON	—	—	—	—	—	—
0.0.8.0.	—	—	—	—	—	—	—	ON	—	—	—	—	—
0.1.0.0.	—	—	—	—	—	—	—	—	ON	—	—	—	—
0.2.0.0.	—	—	—	—	—	—	—	—	—	ON	—	—	—
0.4.0.0.	—	—	—	—	—	—	—	—	—	—	ON	—	—
0.8.0.0.	—	—	—	—	—	—	—	—	—	—	—	ON	—

Notes: 1. "ON" means to short the terminals by a jumper.
 2. "—" means to open the terminals.

Example:



● Digital output test for control output (00-04)

Press **PARA key** until the PROG/SEG display shows (00-04).

When the digit of upper display is changed by ↑, ↓, ←, or → **keys**, the state of voltage pulse or relay control output is changed as shown in Table 11-5.

Since the 6D hardware is of voltage pulse output (0D and 2G hardware is of relay) specification, the ON/OFF check must be performed in meeting with the specification.

Table 11-5.

Upper Display	State
0.0.0.0.	All OFF
0.0.0.1.	6D, 0D, 2G output CH1 ON
0.0.0.2.	6D, 2G output CH2 ON
0.0.0.4.	6D output CH3 ON

● Digital output test for event (00-05)

Press **PARA key** until the PROG/SEG display shows (00-05).

Table 11-6. DO

Upper Display \ DO Terminal Number	④	⑥	⑧	④⑨	⑤⑩	⑤①	⑤②	⑤③
	⑤	⑦	⑨	⑤⑤	⑤⑤	⑤⑤	⑤⑤	⑤⑤
0.0.0.0.	—	—	—	—	—	—	—	—
0.0.0.1.	ON	—	—	—	—	—	—	—
0.0.0.2.	—	ON	—	—	—	—	—	—
0.0.0.4.	—	—	ON	—	—	—	—	—
0.0.0.8.	—	—	—	ON	—	—	—	—
0.0.1.0.	—	—	—	—	ON	—	—	—
0.0.2.0.	—	—	—	—	—	ON	—	—
0.0.4.0.	—	—	—	—	—	—	ON	—
0.0.8.0.	—	—	—	—	—	—	—	ON

Notes: 1. "—" in the table means "OFF".

2. Since the DO hardware is of open collector specification, the ON/OFF check must be performed in meeting with the specification.

■ PV calibration

Scroll \uparrow , \downarrow , \leftarrow , or \rightarrow **keys** to show (1.0.1.1.) on upper display, then press **ENT key**.

● Gain No. select

Press **PARA key** until the PROG/SEG display shows (01-01). Connect calibration device (See Section “11-3 Set Up”).

Input the gain number (See Table 11-9 and Table 11-10) by scrolling \uparrow , \downarrow , \leftarrow , or \rightarrow **keys** the upper display (**ENT key** not required).

● PV zero, span

1. PV zero adjustment

- Press **PARA key** until the PROG/SEG display shows (01-02).
- Adjust your calibration device to an output signal equal to the 0% range value (See Table 11-9), the signal need to be on the input for 10 to 15 seconds.
- Press **ENT key** after display stabilizes.

2. PV span adjustment

- Press **PARA key** until the PROG/SEG display shows (01-03).
- Adjust your calibration device to an output signal equal to the 100% range value (See Table 11-9 and table 11-10).
- Press **ENT key** after display stabilizes.

Table 11-9.

Gain No.	PV Input 0%	PV Input 100%	Connecting Position
0	-12.785mV	110.000mV	Between 34(+) and 33(-)
1	-8.565mV	53.303mV	Between 34(+) and 33(-)
2	-13.788mV	40.481mV	Between 34(+) and 33(-)
3	-12.000mV	23.300mV	Between 34(+) and 33(-)
4	-1.000mV	11.000mV	Between 34(+) and 33(-)
5	-0.100V	1.100V	Between 34(+) and 33(-)
6	-0.500V	5.500V	Between 34(+) and 33(-)
7	-1.000V	11.000V	Between 34(+) and 33(-)
8	0.000mA	20.000mA	Between 34(+) and 33(-)
9	10.000Ω	480.000Ω	Between 34 and 33
10	10.000Ω	178.000Ω	Between 34 and 33
11	0.000Ω	110.000Ω	Between 34 and 33
12	0.000Ω	45.000Ω	Between 34 and 33

Table 11-10.

Gain No.	PV Input 0%	PV Input 100%	Connecting Position
16	-8.000mV	20.000mV	Between 28(+) and 29(-)
17	-20.000mV	70.500mV	Between 28(+) and 29(-)
18	-1.000V	11.000V	Between 27(+) and 26(-)
19	10.000Ω	380.000Ω	Between 30 and 29
20	0.000Ω	110.000Ω	Between 30 and 29

Table 11-11.

Range Table of CH1 TC					Range Table of CH1 RTD					
Group	Type	Code	Range No.	Gain No.	Group	Type	Code	Range No.	Gain No.	
T/C	K (CA)	K09	0	1	RTD	J IS '89 Pt100 (IEC Pt100Ω)	F50	32	9	
	K (CA)	K08	1	2			F46	33	9	
	K (CA)	K04	2	3			F32	34	9	
	K (CA)	K29	3	1			F36	35	9	
	K (CA)	K44	4	3			F38	36	10	
	K (CA)	K46	5	3			F33	37	10	
	E (CRC)	E08	6	0			F05	38	9	
	J (IC)	J 08	7	1			F03	39	9	
	T (CC)	T44	8	3			F01	40	10	
	B (PR30-6)	B18	9	3			J IS '89 J Pt100	P50	48	9
	R (PR13)	R16	10	3		P46		49	9	
	S (PR10)	S16	11	3		P32		50	9	
	W (WRe5-26)	W23	12	2		P36		51	9	
	W (WRe5-26)	W14	13	2		P38		52	10	
	PR40-20	D19	14	4		P33		53	10	
	Ni-Ni-Mo	Z13	15	0		P05		54	9	
	N	U13	16	1		P03		55	9	
	PL II	Y13	17	1		P01		56	10	
	DIN U	Z08	18	2						
	DIN L	Z07	19	0						
Fe-Au-Cr	Z06	20	4							

Range Table of CH2 T/C				
Group	Type	Code	Range No.	Gain No.
T/C	K (CA)	K44	128	16
	K (CA)	K29	129	17

Range Table of CH2 RTD				
Group	Type	Code	Range No.	Gain No.
RTD	J IS '89 Pt100 (IEC Pt100Ω)	F36	160	19
		F01	161	19
	J IS '89 J Pt100	P36	176	19
		P01	177	19

Range Table of CH2 Linear				
Group	Type	Code	Range No.	Gain No.
Linear mA	4 to 20mA	C01	64	8
	0 to 20mA	C08	65	8
Linear mV	0 to 10mV	M01	66	4
	-10 to +10mV	L02	67	3
	0 to +100mV	L01	68	0
Linear V	0 to 1V	L04	69	5
	-1 to 1V	L08	70	5
	1 to 5V	V01	71	6
	0 to 5V	L05	72	6
	0 to 10V	L07	73	7

■ Cold junction sensor calibration

Scroll ↑, ↓, ←, or → **keys** to show (**2.0.2.2.**) on upper display, then press **ENT key**.

●The cold junction input 0%

1. Press **SETUP key** until the PROG/SEG display shows (**02-01**).
2. Press **ENT key** after display stabilizes, AD count is shown on lower display.

●The cold junction AD count data

1. Press **SETUP key** until the PROG/SEG display shows (**02-02**).
2. Press **ENT key** after display stabilizes, AD count is shown on lower display.

●The cold junction temperature data

1. Press **SETUP key** until the PROG/SEG display shows (**02-03**).
2. Connect the thermometer % 5.
3. Scroll ↑, ↓, ←, or → **keys** to set above temperature value(°C).
4. Press **ENT key**.

■ Current output calibration

Scroll ↑, ↓, ←, or → **keys** to show (**4.0.4.4.**) on the upper display, then press **ENT key**.

Connect the digital ammeter across terminals (See Figure 11-9).

●OUT CH1 output calibration

1. Press **PARA key** until the PROG/SEG display shows (**04-01**).
Scroll ↑, ↓, ←, or → **keys** until meter indicates 4.00mA, then press **ENT key**.
2. Press **PARA key** until the PROG/SEG display shows (**04-02**).
Scroll ↑, ↓, ←, or → **keys** until meter indicates 20.00mA, then press **ENT key**.

●OUT CH2 output calibration

1. Press **PARA key** until the PROG/SEG display shows (**06-03**).
Scroll ↑, ↓, ←, or → **keys** until meter indicates 4.00mA, then press **ENT key**.
2. Press **PARA key** until the PROG/SEG display shows (**06-04**).
Scroll ↑, ↓, ←, or → **keys** until meter indicates 20.00mA, then press **ENT key**.

●OUT CH1 output calibration

1. Press **PARA key** until the PROG/SEG display shows (**04-05**).
Scroll ↑, ↓, ←, or → **keys** until meter indicates 4.00mA, then press **ENT key**.
2. Press **PARA key** until the PROG/SEG display shows (**04-06**).
Scroll ↑, ↓, ←, or → **keys** until meter indicates 20.00mA, then press **ENT key**.

11-3 Set Up

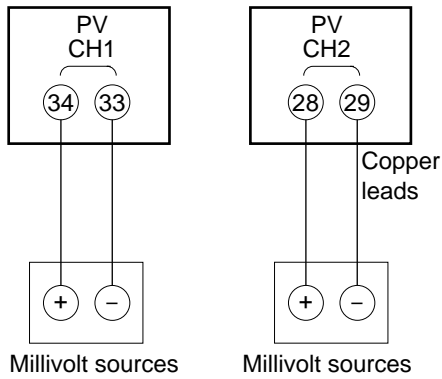

Gain No. 0 to 7

Gain No. 16 to 17

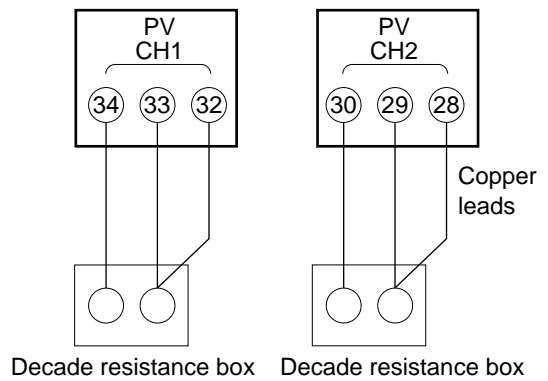

Gain No. 9 to 10

Gain No. 19

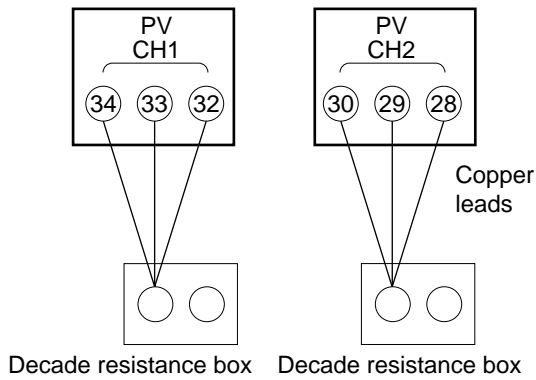

Gain No. 11 to 12(0%)

Gain No. 20(0%)

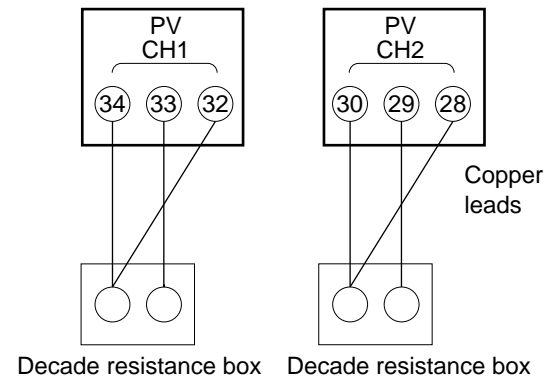

Gain No. 11 to 12(100%)

Gain No. 20(100%)

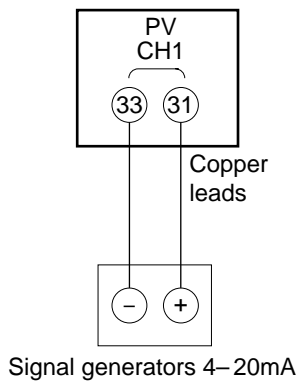

Gain No. 8

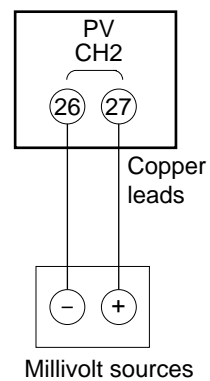

Gain No. 18

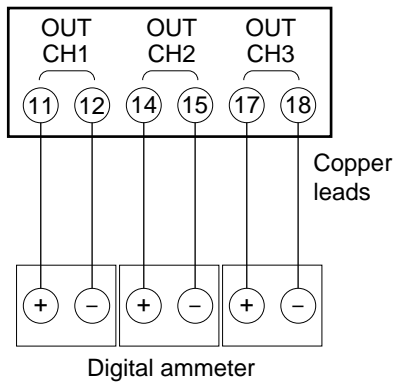

Figure 11-11. Current Outputs

SAFETY REQUIREMENTS

EN2I-6026



To reduce of electrical shock which could cause personal injury, all safety notices in this documentation.



This symbol warns the user of a potential shock hazardous live voltages may be accessible.

- If the equipment is used in a manner not specified by the manufacturer, the protection provided by the equipment must be impaired.
- Do not replace any component (or part) not explicitly specified as replaceable by your supplier.
- All wiring must be in accordance with local norms and carried out by authorized experienced personnel.
- The ground terminal must be connected before any other wiring (and disconnected last).
- A switch in the main supply is required near the equipment.
- Mains power supply wiring requires a (T) 1.0A, 250V fuse(s).(IEC127)

EQUIPMENT RATINGS

Supply voltages	100 to 240Vac (operation power voltages 90 to 264Vac)
Frequency	50/60Hz
Power or current ratings	30VA maximum

EQUIPMENT CONDITIONS

Do not operate the instrument in the presence of flammable liquids or vapors. Operation of any electrical instrument in such an environment constitutes a safety hazard.

Temperature	0 to 50°C
Humidity	10 to 90%RH
Vibration	Frequency 10 to 60Hz Acceleration 1.96m/s ² maximum
Installation category	Category II (IEC664-1, EN61010-1)
Pollution degree	2

EQUIPMENT INSTALLATION

The controller must be mounted into a panel to limit operator access to the rear terminal. Specification of common mode voltage; The common mode voltages of all I/O except for main supply and relay outputs are less than 30Vrms, 42.4V peak and 60Vdc.

APPLICABLE STANDARDS

EN61010-1, EN50081-2, EN50082-2

CAUTION

Danger of explosion if battery is incorrectly replaced.

Replace only with the same or equivalent type recommended by the manufacturer.
Dispose of used batteries according to the manufacturer's instructions.



Pour réduire tout risque de décharge électrique qui pourrait provoquer une lésion corporelle, respectez toutes les consignes de sécurité de cette documentation.



Ce symbole avertit l'utilisateur d'un risque électrique potentiel lorsqu'il peut avoir accès à des éléments sous tension.

- * Si l'équipement est utilisé dans un but non spécifié par le constructeur, la protection fournie avec cet équipement peut être affectée.
- * Aucun composant (ou pièce) ne doit être remplacé s'il n'est pas explicitement spécifié comme tel par le constructeur.
- * Tous les câblages doivent être conformes aux normes locales et doivent être réalisés par un personnel autorisé et expérimenté.
- * La borne de masse doit être raccordée avant tout autre câblage (et débranchée en dernier).
- * Il est obligatoire de connecter cet appareil sur une ligne possédant un moyen de coupure près de l'appareil, d'un accès facile pour l'utilisateur.
- * Le câblage de l'alimentation principale nécessite un ou des fusible(s) 1.0A(T), 250 V. (IEC127)

Catégorie d'installation : Catégorie II (IEC664-1, EN61010-1)

Spécification de tension en mode commun : les tensions en mode commun de toutes les entrées/sorties excepté pour l'alimentation principale et les sorties relais sont inférieures à 30 V eff., 42,4 V en crête et 60 Vcc.

CARACTÉRISTIQUES DE L'ÉQUIPEMENT

Tension d'alimentation 100-240V ~
Fréquence 50/60 Hz
Puissance ou courant 30 VA maximum

CONDITIONS AMBIANTES

Ne jamais utiliser cet équipement en présence de liquides ou de vapeurs inflammables. L'utilisation de tout instrument électrique dans un tel environnement pourrait présenter un risque pour la sécurité.

Température 0 à 50°C
Humidité 10 à 90 %
Vibration Fréquence 10 à 60 Hz
Accélération 1.96m/s² maximum

INSTALLATION DE L'ÉQUIPEMENT

Le contrôleur doit être monté dans un panneau pour limiter l'accès aux bornes arrières par l'opérateur.



Befolgen Sie alle Sicherheitshinweise in diesen Unterlagen, um das Risiko eines Stromschlags zu verringern, der zu Körperverletzung führen kann.



Dieses Symbol warnt den Benutzer vor eventueller Berührungsgefahr, wo lebensgefährliche Spannungen zugänglich sein können.

- * Bei Benutzung der Ausrüstungen auf nicht vom Hersteller angegebene Art und Weise kann der von der Ausrüstung gewährleistete Schutz beeinträchtigt werden.
- * Ersetzen Sie keine Komponente (oder Teil), die/das nicht ausdrücklich vom Lieferanten als ersetzbar angegeben ist.
- * Die gesamte Verkabelung muß den örtlichen Normen entsprechen und von zugelassenem, erfahrener Personal durchgeführt werden.
- * Die Erde muß vor allen anderen Kabeln angeschlossen (und zuletzt abgeklemmt) werden.
- * In der Nähe der Ausrüstung muß ein Schalter in der Hauptstromversorgung vorhanden sein. (vom Bediener leicht zu erreichen)
- * Für die Hauptstromversorgung sind 1.0A, 250 V Sicherungen (T) notwendig. (IEC127)

Installationskategorie : Kategorie II (IEC664-1, EN61010-1)

Spezifikation für Gleichaktspannungen : Die Gleichaktspannungen für alle E/A (Eingänge/Ausgänge) (außer für Spannungsversorgung und Relaisausgänge) sollen 30 V eff bzw, 42,4 V Spitzenspannung und 60 VGS nicht überschreiten.

AUSRÜSTUNGSDATEN

Netzspannung	100 bis 240V WS
Frequenz	50/60 Hz
Nennleistung	30 VA maximal

UMGEBUNGSBEDINGUNGEN

Betreiben Sie das Gerät nicht in Gegenwart entflammbarer Flüssigkeiten oder Dämpfe. Der Betrieb elektrischer Geräte in solchen Umgebungen stellt ein Sicherheitsrisiko dar.

Temperatur	0 bis 50° C
Feuchtigkeit	10 bis 90 %
Vibration	Frequenz 10 bis 60 Hz Beschleunigung 1.96m/s ² maximal

ANBRINGUNG DER AUSRÜSTUNGEN

Der Regler muß in ein Pult eingebaut sein, damit der Bediener nicht zu oft auf die hinteren Anschlüsse zugreifen muß.



Per ridurre il rischio di scossa elettrica con conseguente danno alle persone, seguire le norme di sicurezza indicate nella presente documentazione.



Questo simbolo avverte del pericolo di scossa elettrica nelle aree in cui sono accessibili conduttori sotto tensione.

- * Se si utilizza l'apparecchio in modo diverso da quello specificato dalla ditta produttrice, è possibile che venga danneggiata la protezione fornita dall'apparecchio stesso.
- * Non sostituire alcun componente, o parte, che non sia stato espressamente definito "sostituibile" dal fornitore.
- * Tutti i collegamenti elettrici devono essere conformi alle norme locali ed effettuati da personale autorizzato.
- * Il terminale di terra deve essere collegato prima degli altri cavi e scollegato per ultimo.
- * È necessario che sia presente un interruttore nell'alimentazione principale accanto all'apparecchio, a portata dell'operatore.
- * Il cablaggio di alimentazione rete richiede (T)1.0A, fusibili 250 V. (IEC127)

Categoria de installazione : Categoria II (IEC664-1, EN61010-1)

Specificazione dei voltaggi nel modo comune : I voltaggi nel modo comune de todos los ingresos/uscite eccetto per l'alimentazione principale e le uscite relé sono inferiores a 30 V eff., 42,4 V picco e 60 Vdc.

DATI NOMINALI

Voltaggio	100 a 240 V~
Frequenza	50/60 Hz
Potenza o potenza nominale corrente	30 VA massimo

CONDIZIONI AMBIENTALI

Non far funzionare l'apparecchio in presenza di liquidi o gas infiammabili, in quanto questo potrebbe essere estremamente pericoloso.

Temperatura	Da 10 a 50° C
Umidità	Dal 10 al 90%
Vibrazioni	Frequenza 10 a 60 Hz Accelerazione 1.96m/s ² massimo

INSTALLAZIONE DELL'APPARECCHIO

Il dispositivo di controllo deve essere montato su un pannello per limitare l'accesso ai terminali posteriori.



Teneinde het gevaar voor elektrische schokken die verwondingen kunnen veroorzaken te verminderen, alle instructies van deze documentatie navolgen.



Dit symbool waarschuwt de gebruiker voor een potentieel schokgevaar wanneer toegang bestaat tot onderdelen die onder gevaarlijke spanning staan.

- * Wanneer de apparatuur op een manier wordt gebruikt die niet door de fabrikant is aanbevolen kan de beveiliging van de apparatuur haar doeltreffendheid verliezen.
- * Geen onderdelen vervangen die niet als vervangbaar zijn aangeduid door onze leverancier.
- * Alle bedrading dient conform te zijn aan lokale normen en te worden aangelegd door bevoegd ervaren personeel.
- * De beaarding dient vóór elke andere bedrading te worden aangesloten (en als laatste te worden ontkoppeld).
- * Een hoofdnetschakelaar, gemakkelijk bereikbaar door de operateur, is in de nabijheid van deze apparatuur vereist.
- * Een zekering (T)1.0A,250 V, is vereist voor de bedrading van het voedingsnet. (IEC127)

Installatie Categorie : categorie II (IEC664-1, EN61010-1)

Specificatie van de spanningen in algemene mode : De algemene mode spanningen voor alle I/O behalve de netvoeding en de relais uitgangen zijn van minder als 30V r.m.s., 42,4V spanningspiek en 60V gelijkstroom.

TECHNISCHE GEGEVENS

Voedingsspanning	100/240 V~
Frequentie	50/60 Hz
Vermogen of stroomvermogen	max. 30 VA

OMGEVING

Gebruik het apparaat niet bij brandbare vloeistoffen of dampen. Het gebruik van elektrische apparatuur in zo'n omgeving is gevaarlijk.

Omgevingstemperatuur	0 tot 50°C
Vochtigheidsgraad	10 tot 90%
Trilling	Frequentie 10 tot 60 Hz
	Acceleratie 1.96m/s ² max.

INSTALLATIE VAN DE APPARATUUR

De controle-eenheid dient op een paneel te worden gemonteerd om toegang door de operateur tot de achteraanluitklemmen te verhinderen.



Para reducir el riesgo de una descarga eléctrica que podría ocasionar daños personales siga atentamente las instrucciones de esta documentación.



Este símbolo previene al usuario de un riesgo potencial de descarga cuando se puede acceder a corrientes de tensión peligrosas.

- * Si el equipo se utiliza de manera distinta a la especificada por el fabricante, la protección procurada por el equipo puede verse perturbada.
- * No sustituya ningún componente (o parte de él) que no esté señalado como reemplazable de manera específica por su proveedor.
- * Todos los cables deben estar en conformidad con las normas locales y ser instalados por un personal autorizado y competente.
- * El borne de tierra debe conectarse antes que cualquier otro cable (y ser desconectado en último lugar).
- * Debe haber un interruptor en la red principal cerca del equipo. (Fácil acceso para el operador)
- * Los cables de suministro de la red eléctrica requieren fusibles (T) 1.0A, 250V. (IEC127)

Categoría de instalación : Categoría II (IEC664-1, EN61010-1)

Especificación de los voltajes en el modo común : los voltajes en el modo común de las entradas/salidas salvo para la red principal y las salidas de relé son inferiores a 30 V eff., 42,4 V pico y 60 Vcc.

CONDICIONES DE FUNCIONAMIENTO DEL EQUIPO

Tensión de suministro : 100 a 240 V~
Frecuencia : 50/60 HZ
Potencia o corriente: 30 VA máximo

CONDICIONES DEL ENTORNO

No utilice el instrumento en presencia de líquidos o gases inflamables. La utilización de cualquier instrumento eléctrico en tal entorno constituye un riesgo para la seguridad.

Temperatura: 0 a 50°C
Humedad : 10 a 90 %
Vibración : frecuencia 10 a 60 Hz
 aceleración 1.96m/s² máximo

INSTALACIÓN DEL EQUIPO

El controlador debe ser montado en un tablero, para limitar el acceso del operador a los bornes traseros.



Para reduzir o risco de choque eléctrico que pode causar danos físicos, siga todas as instruções de segurança contidas nesta documentação.



Este símbolo avisa o utilizador sobre um eventual perigo de choque quando são acessíveis voltagens sob tensão perigosas.

- * Se o equipamento for utilizado de uma forma não especificada pelo fabricante, a protecção normalmente facultada pode falhar.
- * Não se deve substituir qualquer componente (ou peça) que não seja explicitamente especificado como substituível pelo nosso revendedor.
- * Todos os fios devem estar em conformidade com as normas locais e instalados por profissionais autorizados.
- * O terminal de terra deve ser ligado antes de qualquer outro fio (e desligado em último lugar).
- * É necessário um interruptor na alimentação principal perto do equipamento ao alcance do operador.
- * Os fios de alimentação principal necessitam de fusíveis (T) 1.0A; 250V. (IEC127)

Categoria de instalação: categoria II (IEC664-1, EN61010-1).

Especificação respeitante às tensões ordinárias: as tensões ordinárias de quaisquer entradas/saídas, exceptada a alimentação dos sectores e das saídas relés, são inferiores a 30V r.m.s. (valor eficaz), 42,4V tensão máxima e 60 V dc (corrente contínua).

ESPECIFICAÇÕES DO EQUIPAMENTO

Voltagem	100/240 V~
Frequência	50/60 Hz
Potência	30 VA máximo

CONDIÇÕES DO MEIO AMBIENTE

Não colocar o equipamento em funcionamento na presença de líquidos ou vapores inflamáveis. A utilização de qualquer equipamento eléctrico num ambiente deste tipo comporta riscos de segurança.

Temperatura	0 a 50°C
Humidade	10 a 90%
Vibração	Frequência 10 a 60 Hz
	Acceleração 1.96m/s ² máximo

INSTALAÇÃO DO EQUIPAMENTO

O controlador deve ser montado num painel para limitar o acesso do operador aos terminais traseiros.



Για να αποφύγετε τον κίνδυνο ηλεκτροπληξίας που μπορεί να προκαλέσει τραυματισμό ατόμων, ακολουθήστε όλες τις οδηγίες ασφαλείας του φυλλαδίου.



Αυτό το σύμβολο προειδοποιεί το χρήστη για μία δυνατότητα κινδύνου ηλεκτροπληξίας όταν μπορεί να υπάρχει πρόσβαση σε επικίνδυνες τάσεις.

- * Εάν ο εξοπλισμός χρησιμοποιείται κατά τρόπο που δεν περιγράφεται από τον κατασκευαστή, η προστασία που προσφέρεται από το προϊόν μπορεί να αλλοιωθεί.
- * Μην αλλάζετε κανένα ανταλλακτικό (ή μέρος) που δεν αναφέρεται καθαρά ότι μπορεί να αντικατασταθεί από τον προμηθευτή μας.
- * Όλες οι καλωδιώσεις πρέπει να είναι σύμφωνες με τις τοπικές προδιαγραφές και να γίνονται από ειδικευμένο έμπειρο προσωπικό.
- * Η γείωση πρέπει να συνδεθεί πριν από οποιοδήποτε άλλο καλώδιο (και να αποσυνδέεται τελευταίο).
- * Ένας διακόπτης στην κεντρική τροφοδοσία είναι απαραίτητος κοντά στον εξοπλισμό, εύκολης πρόσβασης για τον χειριστή.
- * Η τροφοδοσία σε ρεύμα απαιτεί μία ασφάλεια (T) 1.0A, 250V. (IEC127)

Κατηγορία Εγκατάστασης : Κατηγορία II (IEC664-1, EN61010-1)

Προδιαγραφή τάσεων κοινής διακυμανσης: Οι τάσεις κοινής διακυμανσης όλων των εισόδων και εξόδων (I/O), εκτός από την κυρία τροφοδοσία και τις εξόδους ρελε είναι λιγότερο από τα 30V r.m.s., 42.4V μέγιστη στιγμιαία τάση (peak) και 60V συνεχούς τάσης (DC).

ΧΑΡΑΚΤΗΡΙΣΤΙΚΑ ΕΞΟΠΛΙΣΜΟΥ

Τάση τροφοδοσίας	100/240 V~
Συχνότητα	50/60 Hz
Ισχύς ρεύματος	30 VA μέγιστη

ΣΥΝΘΗΚΕΣ ΠΕΡΙΒΑΛΛΟΝΤΟΣ

Μη βάζετε σε λειτουργία το όργανο σε παρουσία εύφλεκτων υγρών ή ατμών. Λειτουργία σε τέτοιο περιβάλλον είναι επικίνδυνο για την ασφαλεία.

Θερμοκρασία	0 έως 50° C
Υγρασία	10 έως 90%
Δονήσεις	Συχνότητα 10 έως 60 Hz Επιτάχυνση 1.96m/s ² μέγιστη

ΕΓΚΑΤΑΣΤΑΣΗ ΕΞΟΠΛΙΣΜΟΥ

Ο ελεγκτής πρέπει να συναρμολογηθεί σε πίνακα για να περιορισθεί η πρόσβαση του χειριστή στους πίσω ακροδέκτες.



For at reducere risikoen for elektrisk stød og dermed forbundet personskade er det nødvendigt at følge sikkerhedsforskrifterne i følgende dokumentation.



Dette symbol advarer brugeren om en potentiel berøringsfare, såfremt der kan være adgang til den livsfarlige netspænding.

- * Såfremt udstyret anvendes på anden måde end den, producenten har angivet, kan det betyde en forringelse af udstyrets sikkerhed.
- * Udskift ikke nogen komponent (eller del), som leverandøren ikke specifikt har angivet er udskiftelig.
- * Al ledningsføring skal være i overensstemmelse med nationale standarder og skal udføres af autoriseret personale med behørig erfaring.
- * Jordklemmen skal tilsluttes inden andre ledninger (og skal afmonteres sidst).
- * Det er nødvendigt med en afbryder til strømforsyningen nær udstyret og i umiddelbar nærhed af operatøren.
- * Tilslutning til strømforsyning kræver en (T) 1.0A, 250V sikring. (IEC127)

Installationskategori: kategori II (IEC664-1, EN61010-1)

Specifikation af almindelige spændinger: De almindelige spændinger over alle I/O undtagen netspændingen og relæudgangene er mindre end 30 V r.m.s., 42,4 V spids og 60 V jævnstrøm.

UDSTYRETS MÆRKEVÆRDIER

Netspænding	100/240 V~
Frekvens	50/60 Hz
Nominel effekt	30 VA maksimum

MILJØFORHOLD

Brug ikke instrumentet i nærheden af brandfarlige væsker eller dampe. Anvendelse af elektriske instrumenter i et sådant miljø udgør en sikkerhedsrisiko.

Temperatur	0 til 50° C
Fugtighed	10 til 90 %
Vibration	Frekvens 10 til 60 Hz
	Acceleration 1.96m/s ² maksimum

INSTALLATION AF UDSTYR

Styreenheden skal monteres i en plade eller et panel for at begrænse operatørens adgang til de bageste klemmer.



Följ noga handbokens samtliga säkerhetsföreskrifter för att undvika elstötar och åtföljande personsador.



Denna symbol varnar användaren för risk för elchock vid tillfällig åtkomst av spänningsförande del.

- * Om utrustningen används på ett sätt som ej förutsetts av tillverkaren kan säkerhetsskyddet visa sig vara otillräckligt.
- * Byt inte ut någon komponent (eller del) om denna inte klart angivits som utbytbar av tillverkaren.
- * All kabeldragning skall följa de lokala föreskrifterna och utföras av en kompetent och erfaren fackman.
- * Jorduttaget måste anslutas innan all annan kabeldragning (och kopplas från sist).
- * En nätströmbrytare skall finnas i närheten av utrustningen, inom bekvämt räckhåll för operatören.
- * Huvudnätets kabeldragning kräver (T) 1.0A, 250V säkring(ar). (IEC127)

Installationskategori: kategori II, (IEC664-1, EN61010-1)

Specifikationer för vanliga nätspänningar: De vanliga nätspänningarna för alla I/O utom för huvudströmsförsörjningen och reläuttagen är mindre än 30V sinuseffekt (r.m.s), 42.4V maximibelastning och 60V dc (likström).

UTRUSTNINGENS MÄRKDATA

Nätspänning	100 till 240 V~
Frekvens	50/60 Hz
Effekt eller märkström	30 VA maximum

MILJÖVILLKOR

Använd inte utrustningen i närheten av lättantändliga vätskor eller ångor. Drift av elektriska instrument i en sådan omgivning är att leka med säkerheten.

Temperatur	0 till 50°C
Fuktighet	10 till 90 %
Vibration	Frekvens 10 till 60 Hz
	Acceleration 1.96m/s ² maximum

INSTALLERING AV UTRUSTNING

Kontrollern skall monteras i en panel för att minska operatörens åtkomst till de bakre terminalerna.



Noudata kaikkia näitä turvaohjeita vammoja aiheuttavien sähköiskujen välttämiseksi



Tämä merkki varoittaa käyttäjää sähköiskun vaarasta paikassa, missä voi koskettaa vaarallisia jännitteitä.

- * Laitteeseen kuuluva suojaus voi heikentyä, jos sitä käytetään valmistajan osoittaman tavan vastaisesti
- * Älä korvaa mitään komponenttia (tai osaa), ellei jälleenmyyjä ole ilmoittanut sen korvauskelpoisuutta.
- * Kaikkien johdotusten on oltava paikallisten standardien mukaiset ja kokeneen, valtuutetun asentajan tekemät.
- * Maadoituspiste on kytkettävä ensimmäisenä ennen muita kytkentöjä (ja irrotettava viimeisenä).
- * Käyttövirran pääkatkaisijan on oltava laitteen lähellä helposti käyttökäytön ulottuvilla.
- * Käyttövirralle tarvitaan 1.0A(T), 250 V sulakkeet. (IEC127)

Laitosluokka : luokka II (IEC664-1, EN61010-1)

Yhteismuotojännitteiden määrittäminen : Kaikien syöttöjen ja antojen yhteismuotojännitteet paitsi pääsyötön ja releantojen yhteismuotojännitteet ovat alle 30 V tehollisjännite, alle 42.4 V huippujännite ja alle 60 V tasavirtajännite.

LAITTEEN NIMELLISARVOT

Käyttöjännite	100/240 V~
Taajuus	50/60 Hz
Teho	30 VA maksimi

KÄYTTÖOLOSUHTEET

Älä käytä laitetta tulenarkojen nesteiden tai kaasujen lähistöllä. Jokainen sähkölaite muodostaa vaaratekijän sellaisessa ympäristössä.

Lämpötila	0 - +50°C
Kosteus	10 - 90%
Tärinä	Taajuus 10 - 60 Hz
	Iihtyvyys 1.96m/s ² maksimi

LAITTEEN ASENNUS

Säätötoiminnot on asennettava paneelille, jotta käyttäjällä olisi rajoitettu pääsy taustakytkentöihin.

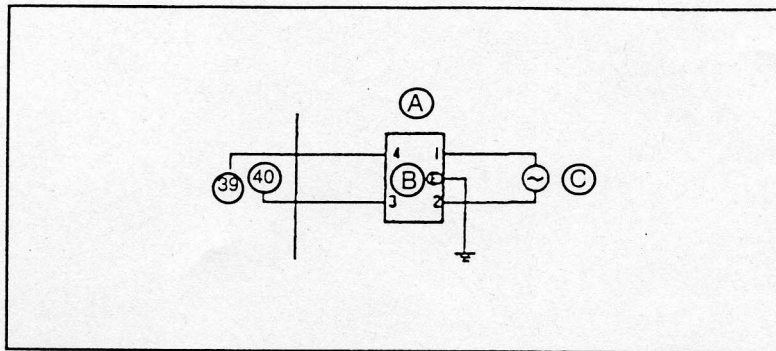

	(A)	(B)	(C)
FR	Filtre antiparasite	Masse	Alimentation de l'appareil 90 à 264 V CA
GE	Störschutzfilter	Erde	Instrumentenstromversorgung 90 bis 264 V Wechselstrom
IT	Filtro rumore	Terra	Alimentazione strumenti 90-264 V CA
SP	Filtro de ruido	Tierra	Tablero suministro de corriente 90 a 264 V corriente alterna
SW	Ljudfilter	Jord	Instrumentkraftuttag 90 till 264 V AC
GR	Φίλτρο θορύβου	Γη	Παροχή Ισχύος για τα Όργανα / 90 με 264 V AC
PO	Filtro de ruído	Terra	Alimentação de instrumento 90 a 264 V AC
DA	Støjfilter	Jord	Strøm til instrumenter 90 - 264 V AC
NL	Geluidsfilter	Aarde	Stroomtoevoer instrumenten Wisselstroom 90 t/m 264 V
FI	Kohinasuodatin	Maadoitus	Instrumentin virtalähde 90 - 264 V vaihtovirtaa
EN	Noise Filter	GND	Instrument power supply 90-264VAC

Index

2 degrees of freedom selection7-11, 7-17
3-lead RS-485 mutual connection4-21
3-position control deviation lower limit7-13
3-position control deviation upper limit7-13
3-position control lower limit hysteresis7-13
3-position control upper limit hysteresis7-13
5-lead RS-485 mutual connection4-20

[A]

ADV (advance)5-15
AUTO5-13, 5-15
Accessories10-8
Add-on terminal base2-1
Add-on terminal layout4-7
Alarm code9-3
Auto-tuning (AT)6-14
Auxiliary output5-30
Auxiliary output (output 3), Connecting4-14
Auxiliary output lower limit7-39
Auxiliary output upper limit7-39

[B]

BAT LED9-13
BAT LED blinking9-11
Basic display state2-2, 2-6
Basic display, Switching the6-2
Basic function1-2
Basic indicator LED lamps2-2, 2-3
Battery replacement procedure9-14
Body2-1

[C]

CCW9-11
CPL communications1-4
CR filter3-2
CW9-11
Cable4-3
Case2-1
Cold junction compensation7-40
Communications, Connecting for4-19
Console2-1, 2-2
Constant-value operation5-12, 5-14
Constant-value operation data7-1
Control output CH15-21
Control outputs (output 1, 2, 3), Connecting4-10
Control/output state LED2-2, 2-3

Controller5-17
Controller status events5-5
Crimped terminal4-4
Current output (5G)4-10
Cycle5-10, 8-14

[D]

DC current2-9, 2-10, 4-8
DC voltage2-9, 2-10, 4-8
Data structure1-3
Data types5-1
Direct motor rotation, Wiring for9-11
Display2-2
Dust-proof cover3-2

[E]

END5-13
Event 1 standby7-24
Event 2 ON delay time7-24
Event 2 standby7-24
Event 3 ON delay time7-24
Event 3 standby7-24
Event LED2-2, 2-4
Event ON delay time7-24
Event configuration data7-1
Event configuration data settings7-18
Event output (relay output), Connecting4-15
Events 1 to 35-3, 8-6
External dimensions10-9
External switch (RSW) input, Connecting4-17
External switch (RSW) operation6-11
External switch inputs6-11

[F]

FAST5-13, 5-15
Feedback resistance4-11
Functions using two or more keys2-7

[G]

G.SOAK5-9, 8-11, 8-12
General reset2-7, 8-20
Ground4-6

[H]

HOLD5-13, 5-15
Hard dust-proof cover10-8, 10-10

Heat/cool output (3D).....4-12
 Heat/cool output (5K).....4-13

[I]

Input 1 square root extraction dropout.....7-38
 Input 1, Connecting4-8
 Input 2 square root extraction dropout.....7-38
 Input 2, Connecting4-8
 Input processing functions.....5-18
 Input type2-9
 Inputs (analog inputs), Connecting.....4-8
 Inputs and outputs, Isolating.....4-22

[K]

Key cover.....2-1
 Key lock.....7-9
 Keys2-5

[L]

Line filter4-6
 Loader jack.....2-5, 2-8
 Lock screw.....2-1
 Low battery voltage LED2-2, 2-3
 Lower display2-2, 2-3

[M]

MANUAL5-13, 5-15
 MANUAL operation.....6-14
 MV change limit.....7-10
 Maintenance.....9-1
 Mode indicator LED lamps2-2, 2-3
 Mode transition.....5-14
 Mode transition operation.....5-15
 Mode types.....5-12
 Model numbers1-5
 Motor adjustment is impossible.....9-11
 Motor control method selection.....7-14
 Motor valve opening adjustment fully open/closed
 time7-15
 Motor valve opening automatic adjustment7-15
 Mounting bracket3-4, 10-8
 Mounting locations3-1
 Mounting method.....3-4

[N]

Noise3-2

[O]

Option10-8
 Output processing functions5-20
 Outputs.....5-29

[P]

PARA key, How to use the.....7-4
 PID operation initial MV7-10
 PID operation initialization.....7-10
 PID parameters 17-1
 PID parameters 1 settings7-25
 PID parameters 27-1
 PID parameters 2 settings7-28
 PID set8-10
 PID set No.....8-9
 PID set auto-switching.....5-8
 PID set selection5-8
 PV display.....7-39
 PV start.....5-10, 8-13
 PV type events5-3
 Panel cut dimensions3-3
 Parameter setup2-6, 7-1, 7-6
 Parameters.....1-3
 Pattern.....5-2, 8-5
 Pattern link5-11, 8-15
 Position-proportional control dead zone.....7-12
 Position-proportional output (2G)4-11
 Power ON, Turning the.....6-1
 Power supply4-6
 Profile display.....2-2, 2-4
 Program.....1-3
 Program No. display2-2
 Program copy2-7, 8-19
 Program end.....5-15
 Program operation5-12
 Program patterns5-2
 Program protect7-9
 Program selection.....6-10, 6-12
 Program No. selection6-10
 Program setup.....2-7, 8-1
 Programmer5-17
 Programming map8-4

Programs, Deleting8-16

[R]

READY5-12
RESET5-15
RS-4854-19
RUN.....5-13, 5-15
Range No.2-9
Relative humidity calculation5-19
Relay output (OD)4-10
Replacing the battery9-13
Resistance temperature detector.....2-9, 2-10, 4-8
Reverse motor rotation, Wiring for9-11

[S]

SP1 limit7-38
SP2 limit7-38
Segment No. display2-2
Segment, Deleting.....8-17
Segment, Inserting8-17
Self-diagnostics.....9-2
Setup data.....7-1
Setup data settings7-31
Smart-tuning method selection.....7-10, 7-17
Soft dust-proof cover.....10-8, 10-10
Specifications.....10-1
Standard terminal base.....2-1
Standard terminal layout.....4-7
System configuration1-4

[T]

Table data.....7-1
Tag5-11
Terminal connections.....4-4
Terminal cover10-8, 10-10
Terminal, Layout of4-5
Thermocouple2-9, 2-10, 4-8
Time display7-39
Time event 1 to 5.....5-6, 8-8
Time event output (open collector), Connecting ..4-16
Time events5-5, 5-6
Trouble during key entry9-5

[U]

Upper display2-2, 2-3

[V]

Variable parameters7-1
Variable parameters 27-1
Variable parameters 2 settings.....7-16
Variable parameters settings.....7-7
Varistor3-2
Voltage output 1 adjustment7-40
Voltage output 2 adjustment.....7-40
Voltage output 3 adjustment7-40
Voltage time-proportional output system7-40

[W]

When to replace the battery9-16
Wiring4-1

[Z]

Zener barrier adjustment.....7-43

HONEYWELL SERVICE CENTERS

NETHERLANDS

HONEYWELL BV
Laaderhoogtweg 18
NL-1101 EA AMSTERDAM ZO
THE NETHERLANDS
Tel.:31 20 56 56 911

POLAND

HONEYWELL Ltd
Ul Augustowka 3
PL-02981 WARSAW
POLAND
Tel.:48 2 642 25 70

REPUBLIC OF IRELAND

HONEYWELL
Unit 5
Long Mile Road
DUBLIN 12
Republic of Ireland
Tel.:353 1 565944

RUSSIA

HONEYWELL INC
Tryokhprundny Pereulok 11.13
SU 10 3001 MOSCOW
Tel.:7095 29 92 531

SOUTH AFRICA

HONEYWELL LTD
34 Harry Street
Robertsham
JOHANNESBURG 2001
REPUBLIC OF SOUTH AFRICA
Tel.:27 11 680 3440

SWEDEN

HONEYWELL A.B.
Storsatragrand 5
S-127 86 STOCKHOLM
SWEDEN
Tel.:46 8 775 55 00

UNITED KINGDOM

HONEYWELL HOUSE
Charles Square
BRACKNELL, BERKS. RG12 1EB
UNITED KINGDOM
Tel.:44 344 424 555

VENEZUELA

HONEYWELL CA
APARTADO 61314
1060 CARACAS
VENEZUELA
Tel.:58 2 239 7533

NORWAY

HONEYWELL A/S
Askerveien 61
PO Box 263
N-1371 ASKER
NORWAY
Tel.:47 66 90 20 30

PORTUGAL

HONEYWELL PORTUGAL LDA
Edificio Suecia II
Av.do Forte nr 3-Piso 3
CARNAXIDE
2795 LINDA A VELHA
PORTUGAL
Tel.:351 4172 602

REP.OF SINGAPORE

HONEYWELL PTE LTD.
BLOCK 750E CHAI CHEE ROAD
06-01 CHAI CHEE IND.PARK
1646 SINGAPORE
REP OF SINGAPORE
Tel.:65 449 7609

SLOVAK REPUBLIC

HONEYWELL
Trnavska 3
831 04 BRATISLAVA
SLOVAKIA
Tel.:42 7 601 23

SPAIN

HONEYWELL
Josefa Valcarcel, 24
PO Box 29106
28080 MADRID
SPAIN
Tel.:34 1 32 02 112

SWITZERLAND

HONEYWELL A.G.
Hertistrasse 2
8304 WALLISELLEN
SWITZERLAND
Tel.:41 1 839 2525

U.S.A

HONEYWELL INC
INDUSTRIAL CONTROLS DIV.
1100 VIRGINIA DRIVE
PA 19034-3260 FT.WASHINGTON
U.S.A
Tel.:215 641 3000

HONEYWELL SERVICE CENTERS

ARGENTINA

HONEYWELL S.A.I.C.
BELGRANO 1156
BUENOS AIRES
ARGENTINA
Tel.:54 1 383 9290

AUSTRALIA

HONEYWELL LIMITED
5 Thomas Holt Drive
North Ryde Sydney
NSW AUSTRALIA 2113
Tel.:61 2 353 7000

BELGIUM

HONEYWELL S.A.
Avenue de Schipol, 3
1140 BRUSSELS
BELGIUM
Tel.:32 2 728 27 11

CANADA

HONEYWELL LIMITED
THE HONEYWELL CENTRE
155 GORDON BAKER RD
M2H 3N7 NORTH YORK, ONTARIO
CANADA
Tel.:416 499 6111

DENMARK

HONEYWELL A/S
Lyngby Hovedgade 98
2800 LYNGBY
DENMARK
Tel.:45 45 93 56 56

FRANCE

HONEYWELL S.A.
4, Avenue Ampere
MONTIGNY LE BRETONNEUX
F-78886 ST QUENTIN EN YVELINES
FRANCE
Tel.:(1) 30 58 80 00

HUNGARY

HONEYWELL Kft
Volgy U 30
H-1026 BUDAPEST
HUNGARY
Tel.:36 1 116 76 59

JAPAN

YAMATAKE Corporation
1-12-2, Kawana
Fujisawa, Kanagawa, 251-8522
Japan
Tel.:81-466-20-2187

ASIA PACIFIC

HONEYWELL ASIA PACIFIC Inc.
Room 3213-3225
Sun Kung Kai Centre
No 30 Harbour Road
WANCHAI
HONG KONG
Tel.:852 829 82 98

AUSTRIA

HONEYWELL AUSTRIA G.m.b.H.
Handelskai 388
A1020 VIENNA
AUSTRIA
Tel.:43 1 213 300

BRAZIL

HONEYWELL DO BRAZIL AND CIA
Rua Jose Alves Da Chunha
Lima 172
BUTANTA
05360 SAO PAULO SP
BRAZIL
Tel.:55 11 819 3755

CZECHIA

HONEYWELL PRAGUE
Krocínovska 3
CS16000 PRAGUE 6
CZECHIA
Tel.:422 243 10 754

FINLAND

HONEYWELL OY
Ruukintie 8
SF-02320 ESPOO
FINLAND
Tel.:358 0 80101

GERMANY

HONEYWELL AG
Kaiserleistrasse 39
Postfach 10 08 65
D-63067 OFFENBACH/MAIN
GERMANY
Tel.:49 69 80 640

ITALY

HONEYWELL S.p.A.
Via Vittor Pisani, 13
20124 MILANO
ITALY
Tel.:39 2 67 731

MEXICO

HONEYWELL S.A.DE CV
AV. CONSTITUYENTES 900
COL. LOMAS ALTAS
11950 MEXICO CITY
MEXICO
Tel.:52 5 259 1966

