

DCP552 Digital Control Programmer

Specification

The DCP552 is a high-function programmer/controller supporting two channels (up to 49 program patterns per channel) to which thermocouple, resistance temperature detector (RTD), DC voltage, DC current and other signals can be input.

The DCP552 supports a memory card interface, 16 event outputs, 16 external switch inputs and a wide range of other functions as part of the standard specification.

FEATURES

- Accuracy of $\pm 0.1\%FS$. Easy-to-view large display characters. Compact design
- Any input type can be selected by console key operation.
- Easy operation aided by guidance messages
- Up to 49 program patterns can be stored to each channel and up to 99 segments can be programmed to each pattern.
- Program patterns can be saved or loaded using the Smart Proximity Card (sold separately).
- The Smart Proximity Card uses highly durable and non-contact type cards

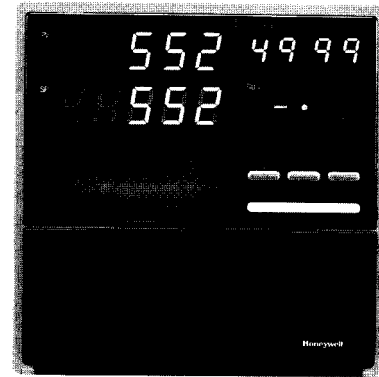

- Any event can be selected to each channel and set for the 16 event outputs, and code events comprising a combination of two or more points can be set.
- 16 external switch inputs allow the control of remote selection of program Nos. or operation on each channel separately or both channels simultaneously
- CE marking-compatible

Applicable standards: EN610 10-1, EN5008 1-2, EN50082-2

BASIC FUNCTION BLOCKS of DCP552

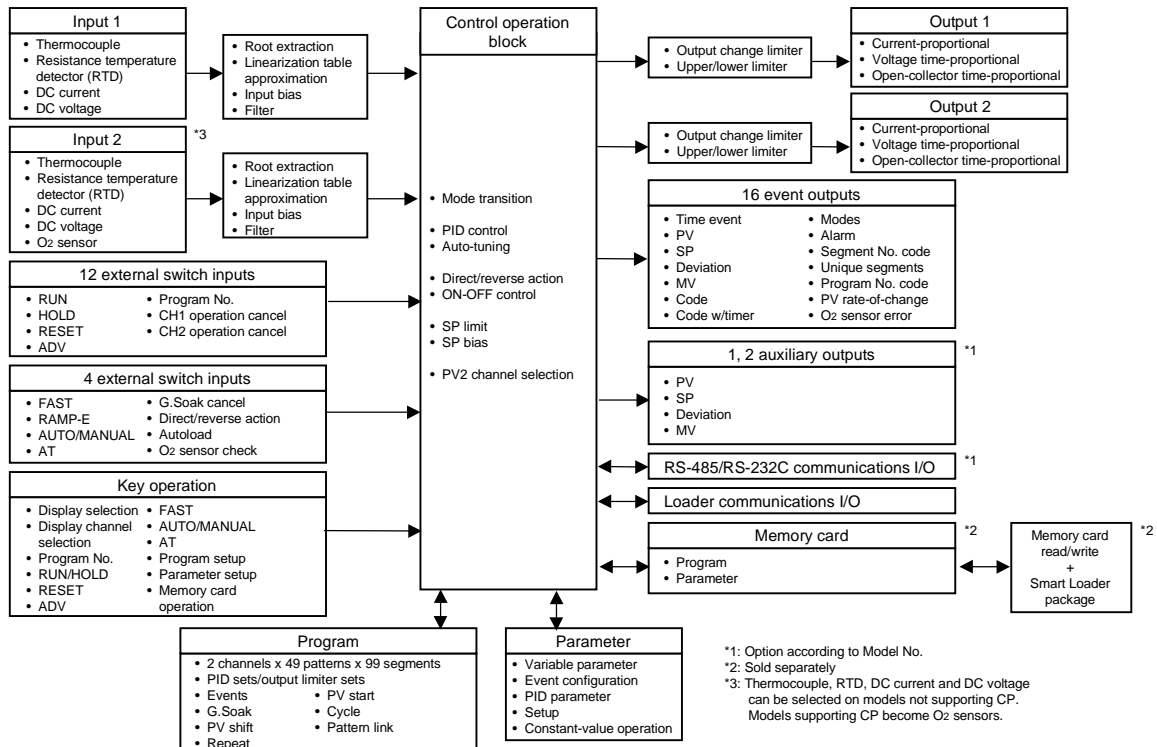

Program	Number of programs	49 programs x 2 channels
	Number of segments	99 per program, total 2000
	Segment setting system	RAMP-X: Set by set points (SP) and time. RAMP-T: Set by set points (SP) and ramp (13) RAMP-E: Set by set points (SP) and ASP per external switch input 1 pulse
	Segment time	0 to 500 hours 0 minute, 0 to 500 minutes 0 second, 0.0 to 3000.0 seconds (time unit selectable)
	Segment ramp	1 to 10000 U/hour, 1 to 10000 U/minute, 1 to 10000 U/second (time unit selectable)
	Segment ASP	1 to 10000 U/l pulse
	Number of sub-functions	4000
	Sub-function action	Events, PID set, output limiter set, G. Soak, PV shift, repeat
	Eventa (16)	Set operating point corresponding to event type
	PID set No.	Set 0 (continuation of previous segment), 1 to 9, A set (automatically switched) and ON-OFF control
	Output limiter aet	Set 0 (continuation of previous segment), 1 to 9
	G.Seek	Set type (start/end points and overall) and G.Soak width 0 to 1000 U.
	PV shift	-10000 to +10000 U
	Repeat	Set return destination segment No. and repeat count.
	PV start	Set type (rising/falling or both) for each program.
	Cycle	Set cycle count for each program.
	Pattern link	Set program No.0 to 49 (0: no link) for each program.
	Tag	Set 8 alphanumeric or symbols for each program.
	Basic time accuracy	±0.01% (segment time setting = 0, with 0.1 second delay for each repeat and cycle)
Inputs	Input type	Thermocouple, resistance temperature detector (RTD), DC voltage, DC current multi-range (See pages 6, 7.)
	Sampling cycle	0.1 seconds
	Input bias current	Thermocouple, DC voltage input: Max. ±1.3 uA (at peak value and reference conditions) 1 V or higher range: Max. -3 µA
	Input impedance	DC current input: approx. 50 Ω (under operating conditions)
	Measuring current	RTD input: Approx. 1 mA current flow from terminal A (under operating conditions)
	Influence of wiring resistance	Thermocouple, DC voltage input: Thermocouple: 0.5 µV/Ω DC voltage (max. 1 V range): 0.5 µV/Ω DC voltage (5 V range): 3 µV/Ω DC voltage (10 V range): 6 µV/Ω RTD input: Max. ±0.01%FS/Ω in wiring resistance range 0 to 10 Ω Range of F01, F33, P01 and P33: ±0.02%FS/Ω max.
	RTD input allowable wiring resistance	• Ranges other than F01, F33, P01 and P33: 85 Ω max. (including Zener barrier resistance. Note that site adjustment is required.) . Ranges of F01, F33, P01 and P33: 10 Ω max. (Zener barrier cannot be used.)
	Allowable parallel resistance	Thermocouple disconnection detection allowable parallel resistance: 1 MΩ min.
	Max. allowable Input	Thermocouple, DC voltage input: -5 to+15V dc DC current input: 50 mA dc, 2.5V dc
	Burnout	Detection selectable
	Over-range detection threshold	110%FS min.: Upscaled -10%FS max.: Downscaled (Note that F50 range is not downscaled.)
	Cold-junction compensation accuracy	±0.5°C (under standard conditions)
	Cold- junction compensation system	Internal/external (0°C only) compensation selectable
	Scaling	-19999 to +20000 U (possible in case of linear input only. Inverse scaling possible. Decimal point position settable at any point)
	Square root extraction	Possible. Dropout: 0.2 to 10.0% in case of DC current or DC voltage range
	PV equalizer (linearization table approximation)	PV1: 9 segments (1 0 points set) PV2: 9 segments (1 0 points set) CP: 9 segments (1 0 points set)
	Input bias	-1000 to +1000 U variable
	Digital filter	0.0 to 120.0 seconds variable (0.0: filter OFF)

external switch inputs	Number of inputs	16	
	Types of connect-able outputs	Dry contacts (relay contact) and open-collector (current sink to ground)	
	Terminal voltage (open)	8.5 V \pm 0.5 V between common terminals (terminals 12, 40) and each input terminal (under operating conditions)	
	Terminal current (short-circuit)	Approx. 6 mA between each terminal (under operating conditions)	
	Allowable contact resistance (dry contact)	ON: 250 ohm max. (under operating conditions) OFF: 100 kohm min. (under operating conditions)	
	Voltage drop (at open-collector ON)	2 V max. (under operating conditions)	
	Leakage current (at open-collector OFF)	0.1 mA max. (under operating conditions)	
	Assignments (fixed)	RUN, HOLD, RESET, ADV, program No., CH1 operation cancel, CH2 operation cancel	
	Assignments (variable)	RAMP-E, FAST, AT, AUTO/MANUAL, G.Soak cancel, auto-load, O ₂ sensor check	
	Input sampling cycle	0.1 seconds	
	ON detection min. hold time	0.2 seconds (0.4 seconds for program No.)	
Indication/programmer	Upper display	Green 5-digit, 7-segment LED This displays PV values in the basic display state. Item codes are displayed in the parameter setup.	
	Lower display	Orange 5-digit, 7-segment LED This displays SP and output % in the basic display state. Setting values are displayed in the parameter setup.	
	Program No. display	Green 2-digit, 7-segment LED This displays program No. in the basic display state.	
	Segment No. display	Green 2-digit, 7-segment LED This displays segment No. in the basic display state. Item Nos. are displayed in parameter setup, and alarm No. is displayed when alarm occurs.	
	Message display	This displays output graph, deviation graph, event state and tags in the basic display state. This displays reference messages in the parameter setup and program setup. This displays operation details and operation results of memory card operation.	
	Profile display	7 orange LEDs Displays program pattern rise, soak and fall trends.	
	Status displays	22 round LEDs Modes: RUN, HLD, MAN, PRG (green) Display details: PV, SP, OUT, TM, CYC, SYN, DEV (green), EG1, EG2 (red) Battery voltage: BAT (red) (blinks at low voltage) Status: AT (green)	
	Operation keys	18 rubber keys	
	Loader connector port	1 (dedicated cable with stereo miniplugs)	
Modes	Progrsm operation modes	READY:	Ready to run program (control stop/program No. selectable)
		RUN:	Program run
	Constant-value operation modes	HOLD:	Program hold
		FAST:	Program, fast-forward
Controller	PID controls	END:	Program end
		READY FAST:	Ready to run and fast-forward program
		AUTO:	Automatic operation
		MANUAL:	Manual operation (output can be controlled on console)
		MANUAL	Manual operation (output can be controlled on console)
Controller	PID controls	Proportional band (P)	0.0 to 1000.0% (0.0: ON-OFF control)
		Reset time (I)	0 to 3600 seconds. 0 seconds: PD control
		Rste time (D)	0 to 1200 seconds. 0 seconds: PI control
		MV limit	Lower limit: -5.0 to upper limit % Upper limit: Lower limit to +105.0%
		Manual reset	0.0 to 100.0%

Controller	PID controls	Number of PID sets	16 sets for program operation (9 segment unique sets + 7 sets for automatic zone selection)	
		PID set selection	Segment designation/automatic zone selection can be switched by program operation.	
		MV change	0.1 to 110.0%/0.1 seconds	
		Auto-tuning	Automatic setting of PiD value by limit cycle system	
		ON-OFF control differential	0 to 1000 U	
	Direct/reverse action switching	Possible		
Outputs	Auxiliary output	Output types	SP1, PV1, deviation 1, MV1, SP2, PV2, deviation 2, O ₂ sensor mV value	
		Scaling	Possible	
	Current output (SG) CH1, CH2 auxiliary outputs CH1, CH2	Output current:	4 to 20 mA dc	
		Allowable load resistance:	600 ohm max. (under operating conditions)	
		Output accuracy:	±0.1%FS max. (under standard conditions)	
Output resolution:		1/10000		
	Max. output current:	21.6 mA dc		
	Min. output current:	2.4 mA dc		
	Output updating cycle:	0.1 seconds		
	Open terminal voltage:	25 V max.		
	Voltage output (6D) CH1, CH2	Allowable load resistance:	600Ω max. (under operating conditions)	
		Load current adjustment:	2 to 22 mA variable	
		Variable open terminal voltage:	25 V max.	
		OFF leakage current:	100 PA max.	
		Output response time:	At ON-OFF 600 Ω load: 0.5 ms max. At OFF-ON 600 Ω load: 0.5 ms max.	
		Output resolution:	1/1000	
		Time-proportional cycle:	1 to 240 seconds variable	
	Open-collector output (8D) CH1 CH2	External supply voltage:	12 to 24 Vdc	
		Max. load current	100 mA/load	
		OFF leakage current:	0.1 mA max.	
		ON residual voltage:	2 V max.	
		Time-proportional cycle:	1 to 240 seconds variable	
Event outputs	Open-collector	External supply voltage:	12 to 24V dc	
		Max. load current:	70 mA/load	
		Max. common current:	500 mA	
		OFF leakage current:	0.1 mA max.	
		ON residual voltage	2 V max.	
	Event types	PV type	PV, deviation, w/deviation standby, absolute value deviation, w/absolute deviation standby, PV rate-of-change, SP, MV, G.Soak absolute value w/G.Soak absolute value deviation standby, PV1 constant operation, PV2 constant operation	
		Time type	Time events, RAMP-E time monitor, segment time, program time	
Code type		Code event, code event w/ timer, program No. binary code, segment No. binary code, program No. BCD code, segment No. BCD code		
Mode type		Unique segment, RUN+HOLD+END+FAST, HOLD, READY+READY FAST, END G.Soak standby, MANUAL, AT executing, FAST+ READY FAST, console operation in progress, RUN, advance, all alarms, PV range alarm, controller alarm, O ₂ sensor error, low battery voltage		
Event hysteresis	In case of PV type set, 0 to 1000 U			
Event ON delay	0.0 to 3000.0 can be set to four events			
Communications	RS-485	Network	Multidrop This controller is provided with only slave instrument functionality except connected to ST221 (dedicated display device). 1 to 16 units max. (DIM) 1 to 31 units max. (CMA, SCM)	
		Data flow	Half duplex	
		Synchronization	Start-stop synchronization	
		Transmission system	Balanced (differential)	
		Data line	Bit serial	
		Signal line	5 transmit/receive lines (3-wire connection also possible)	
		Transmission speed	1200, 2400, 4800, 9600 bps	
		Transmission distance	500 m max. (total) (300 m max. for MA500 DIM connection)	
		Other	Conforming to RS-485 interface specifications	

Communications	RS-485		Char. bit count	11 bits/character		
			Format	1 start bit, even parity, 1 stop bit; or 1 start bit, no parity, and 2 stop bits		
			Data length	8 bits		
			Isolation	All inputs and outputs are completely isolated except external switch inputs.		
	RS-485 communications can be performed by connecting to a computer equipped with an RS-485 interface.					
	RS-232C		Network	1:1 Connected, This controller is provided with only slave instrument functionality.		
			Data flow	Half duplex		
			Synchronization	Start-stop synchronization		
			Transmission system	Unbalanced type		
			Data line	Bit serial		
			Signal line	3 transmit/receive lines		
			Transmission speed	1200, 2400, 4800, 9600 bps		
			Transmission distance	15 m max.		
			Other	Conforming to RS-232C interface specifications		
Char. bit count			11 bits/character			
Format			1 start bit, even parity, 1 stop bit; or 1 start bit, no parity, and 2 stop bits			
Data length			8 bits			
Isolation			All inputs and outputs are completely isolated except external switch inputs.			
Program, PiD, various parameters (SETUP, PARA, event) and other data can be saved and loaded to and from memory card (sold separately).						
Save (SAVE)		Function for copying DCP552 data to memory card.				
Load (LOAD)		Function for copying memory card data to DCP552.				
Memory card (sold separately)						
Memory card	Model No.	Memory Type	Size (bytes)	Number of Programs	Battery Replacement	Parameters
	SKM008A	RAM	7.00 K	Max. 10	Not possible	Setup data
	SKM018A	RAM	14.50 K	Max. 26	Not possible	Variable parameters
	SKM064A	RAM	61.75 K	Max. 49	Not possible	PID parameters
<ul style="list-style-type: none"> • Number of bytes per program is 26 + (5x number of segments) + (5x number of sub-functions). • Number of bytes per parameter <ul style="list-style-type: none"> Setup data: 217 bytes (17+2x100) Variable parameters: 257 bytes (17+2x120) PID parameters+ constant-value operation data: 565 bytes (17+2x2x8x16+2x2x9) Event configuration data: 209 bytes (17+2x3x32) 						
General specifications	Memory backup	Memory	Battery backed up RAM			
	Battery life		Controller power OFF: Approx. 5 years under standard conditions			
			Controller power ON: Approx. 10 years under standard conditions			
	Rated power voltage	100 to 240V ac, 50/60 Hz				
	Power consumption	25 VA max.				
	Power ON rush current	50A max.				
	Power ON operation	Reset time: 10 seconds max. (time until normal operation is possible under normal operating conditions)				
	Allowable transient power loss	20 ms max. (under operating conditions)				
	Insulation resistance	Min. 50 MΩ across power terminal 39 or 40 and FG terminal 52 or 53 (by 500V dc megger)				
	Dielectric strength	1500V ac 50/60 Hz for 1 minute between power terminal and FG terminal Note) The primary side and secondary side capacities are joined inside the product. For this reason, when carrying out a withstand voltage test, disconnect the wiring of the grounded secondary side terminals (e.g. when grounding type thermocouple is used) from the terminal. if the test is carried out with the wiring as it is, this might result in malfunction,				
	Standard conditions	Ambient temperature	23±2°C			
Ambient humidity		60±5%RH				
Rated power voltage		105V ac±1%				
Power frequency		50±1 Hz, or 60±1Hz				
Vibration resistance		0 m/s ²				
Shock resistance		0 m/s ²				
Mounting angle		Reference plane(vertical)±3°				

General specifications	Operating conditions	Ambient temperature range	0 to 50°C (ambient temperature at the bottom side of case when gang-mounted)		
		Ambient humidity range	10 to 90%RH (condensation not allowed)		
		Rated power voltage	100 to 240V ac		
		Allowable power voltage	90 to 264V ac		
		Power frequency	50±2 Hz, or 60±2 Hz		
		Vibration resistance	0 to 1.96 m/s ²		
		Shock resistance	0 to 9.80 m/s ²		
		Mounting angle	Reference plane (vertical) ±10 degrees		
	Transport/storage conditions	Ambient temperature range	-20 to +70°C		
		Ambient humidity range	10 to 95%RH (condensation not allowed)		
		Vibration resistance	0 to 4.90 m/s ² (1 0 to 60 Hz for 2 hours each in X, Y and Z directions)		
		Shock resistance	0 to 490 m/s ² (3 times vertically)		
		Package drop test	Drop height: 60 cm (1 angle, 3 edges and 6 planes; free fall)		
	Terminal ecrew	M3.5 self-tapping screws			
	Terminal screw tightening torque	0.76 to 0.98 N·m			
Mask/case materials	Mask Multilon	Case: Multilon			
Mask/case color	Mask: Dark gray (Munsell5Y3.5/1)	Case: Light gray (Munsell2.5Y7.5/1)			
Installation	Specially designed mounting bracket				
Weight	Approx. 1.5 kg				
Standard accessories	Item	Model No.	Q'ty		
	Unit indicating label	—	1		
	Mounting bracket	81446044-001	1 set (2 p'ces)		
	User's Manual	CP-UM-5017E	1		
	Auxiliary parts (sold separately)	Item	Model No.	Q'ty	
Soft dust-proof cover		61446141-001	—		
Lithium battery set		81448140-001	Approx. 200 g		
Memory csrd (RAM, battery replacement not possible)		SKM008A SKM016A SKM064A	Approx. 30 g		

Table 1 Input Types and Ranges (selectable in setup)

● Thermocouple

Input Type			Input Range (FS)		Accuracy (under standard conditions)	
Symbol	Code	Range No.	°C	°F		
K (CA)	K46	16	-200.0 to +200.0	-300.0 to +400.0	±0.1%FS	
K (CA)	K09	0	0.0 to 1200.0	0 to 2400	±0.1%FS	
K (CA)	K08	1	0.0 to 800.0	0 to 1600	±0.1%FS	
K (CA)	K04	2	0.0 to 400.0	0 to 750	±0.1%FS	
E (CRC)	E08	3	0.0 to 800.0	0 to 1800	±0.1%FS	
J (IC)	J08	4	0.0 to 800.0	0 to 1600	±0.1%FS	
T (CC)	T44	5	-200.0 to +300.0	-300 to +700	±0.1%FS	±0.3%FS between -200°C to -45°C
B (PR30-6)	B18	6	0.0 to 1800.0	0 to 3300	±0.1%FS	±4.0%FS between 0 to 260°C, ±0.15%FS between 260 to 800°C
R (PR13)	R16	7	0.0 to 1600.0	0 to 3100	±0.1%FS	
S (PR10)	S16	8	0.0 to 1600.0	0 to 3100	±0.1%FS	
W (WRe5-26)	W23	9	0.0 to 2300.0	0 to 4200	±0.1%FS	
W (WRe5-26)	W14	10	0.0 to 1400.0	0 to 2552	±0.1%FS	
PR40-20	D19	11	0.0 to 1900.0	0 to 3400	±0.2%FS	±0.9%FS between 0 to 300°C, ±0.5%FS between 300 to 800°C
N	U13	12	0.0 to 1300.0	32 to 2372	±0.1%FS	
PLII	Y13	13	0.0 to 1300.0	32 to 2372	±0.1%FS	
Ni-Ni-Mo	Z13	14	0.0 to 1300.0	32 to 2372	±0.1%FS	
Golden iron chromel	206	15	0.0 to 300.0 K (K: Kelvin)		±0.4%FS	

● Resistance temperature detector (RTD)

Input Type			Input Range (FS)		Accuracy (under standard conditions)	
Symbol	Code	Range No.	°C	'F		
JIS'89Pt100 (IEC Pt100 Ω)	F50	64	-200.0 to +500.0	-300.0 to +900.0	±0.1%FS	
	F46	65	-200.0 to +200.0	-300.0 to +400.0	±0.1%FS	
	F32	66	-100.0 to +150.0	-150.0 to +300.0	±0.1%FS	
	F36	67	-50.0 to +200.0	-50.0 to +400.0	±0.1%FS	
	F33	68	-40.0 to +60.0	-40.0 to +140.0	±0.15%FS	
	F01	69	0,0 to 100.0	0.0 to 200.0	±0.15%FS	
	F03	70	0.0 to 300.0	0.0 to 500.0	±0.1%FS	
	F05	71	0,0 to 500.0	0.0 to 900.0	±0.1%FS	
JIS'89JPt100	P50	96	-200.0 to +500.0	-300.0 to +900.0	±0.1%FS	
	P46	97	-200.0 to +200.0	-300.0 to +400.0	±0.1%FS	
	P32	98	-100.0 to +150.0	-150,0 to +300.0	±0.1%FS	
	P36	99	-50.0 to +200.0	-50.0 to +400.0	±0.1%FS	
	P33	100	-40.0 to +60.0	-40.0 to +140.0	±0.15%FS	
	P01	101	0.0 to 100.0	0.0 to 200.0	±0.15%FS	
	P03	102	0.0 to 300.0	0.0 to 500,0	±0.1%FS	
	P05	103	0,0 to 500,0	0.0 to 900,0	±0.1%FS	

● DC current, DC voltage

Input Type			Input Range (FS)		Accuracy (under standard conditions)	
Symbol	Code	Range No.				
mA (linear)	C01	48	4 to 20 mA	Programmable range -19999 to +20000 (decimal point position can be changed)	±0.1%FS	
	Z51	52	2.4 to 20 mA		±0.1%FS	
mV (linear)	M01	49	0 to 10 mV	(decimal point position can be changed)	±0.1%FS	
	L02	50	-10 to +10 mV		±0.1%FS	
	—	51	0 to 100 mV		±0.15%FS	
mA (linear)	C01	128	4 to 20 mA	Programmable range -19999 to +20000 (decimal point position can be changed)	±0.15%FS	
	Z51	134	2.4 to 20 mA		±0.1%FS	
V (linear)	—	129	0 to 1 V	(decimal point position can be changed)	±0.1%FS	
	—	130	-1 to +1 V		±0.1%FS	
	Vol	131	1 to 5 V		±0.1%FS	
	—	132	0 to 5V		±0.1%FS	
	—	133	0 to 10 V		±0.1%FS	
O ₂ sensor*	—	135	0 to 1250 mV Carbon potential (CP value) indication range: 0.000 to 4.000% C (Note that PID control is calculated in input range 0.000 to 2.000% C.) O ₂ partial pressure (PO ₂) indication range: 0.000 to 1.500 x 10 ⁻²⁰ atm	±0.1%FS	When converted to mV value	

- * Any O₂ sensor made by Marathon Monitors, Cambridge, Corning, AACC (Advanced Atmosphere Control Corporation), and Furnace Control can be used.
- PV2 is fixed for the O₂ sensor in the case of models supporting carbon potential.

! Handling Precautions

- The unit of code Z06 is Kelvin (K).
- The PV lower limit alarm does not occur with codes F50 and P50.
- The number of digits past the decimal point for DC current and DC voltage is programmable within the range 0 to 4.
- The PV upper limit alarm is output by the O₂ sensor when the voltage exceeds 1375 mV. The PV lower limit alarm, however, is not output.

MODEL SELECTION GUIDE

Key # - I - II - III - IV - V

Key No.	I	II	III	IV	V	Specifications
	—	Number of PV inputs	Carbon Potential	Option	Additions	
DCP552						Digital Programmable Controller (2-loop model)
	E					Universal Output
		2				Two Inputs
			0			None
			1			Oxygen Sensor Input for Carbon Potential
				0		None
				1		1 Auxiliary output
				2		2 Auxiliary outputs, Communications
					00	None

EXTERNAL DIMENSIONS

(Unit: mm)

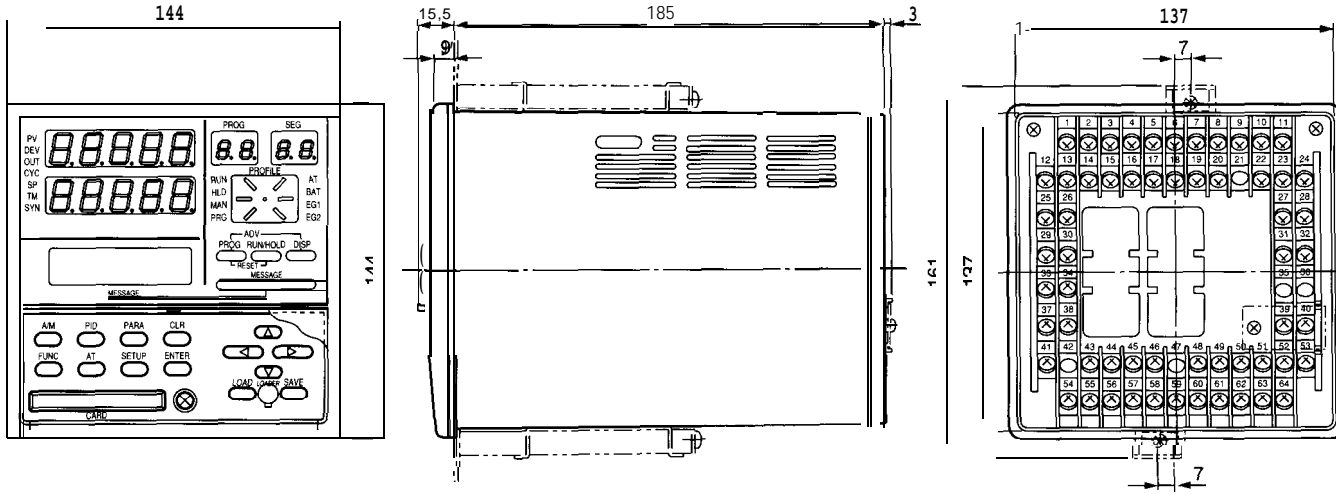

PANEL CUTOUT

(Unit: mm)

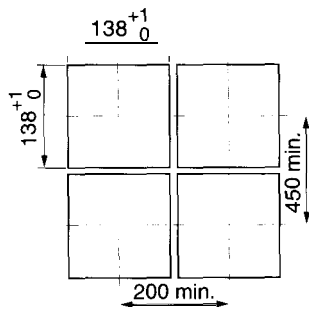

WIRING

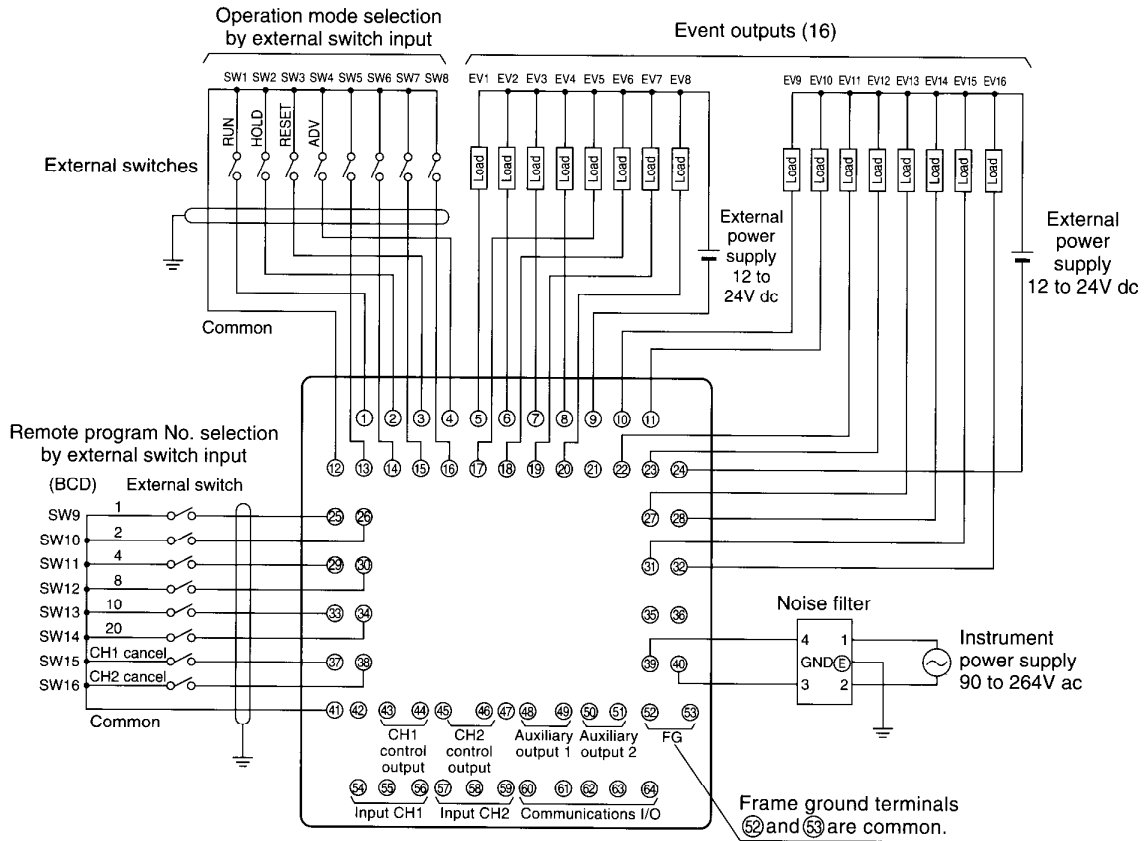

Input

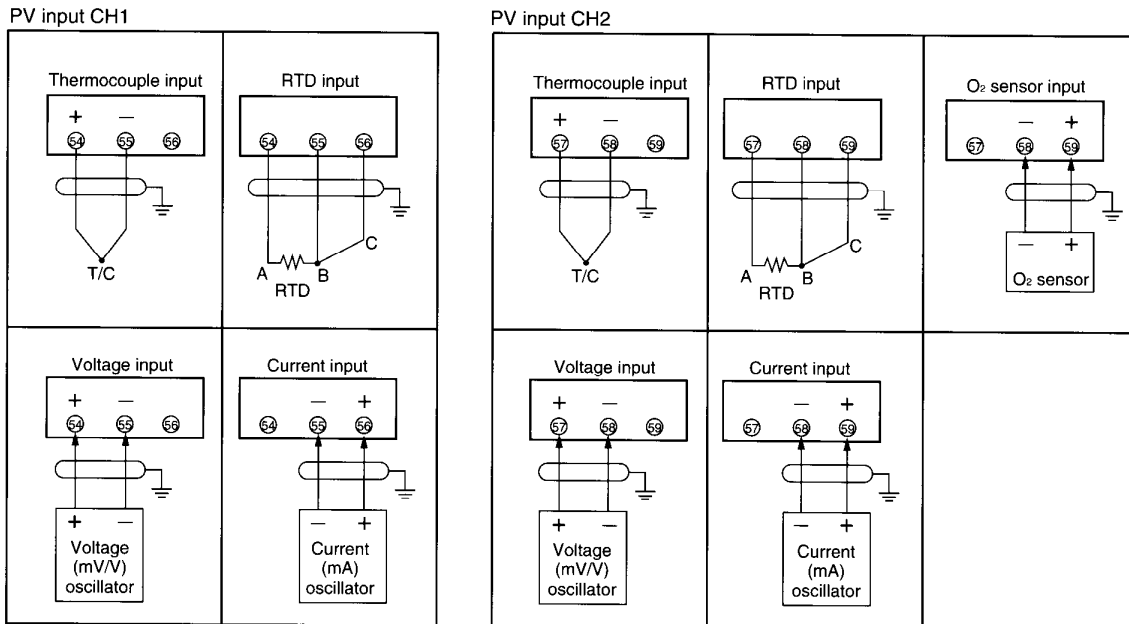

Note: If voltage mode signals are input to PV input CH1 (terminal Nos. 55, 56) and input CH2 (terminal Nos. 58, 59) for current input by mistake, a large current might flow and cause the controller to malfunction. Before wiring to the current input terminals on the DCP552, make sure that current input signals are output correctly within the range 4 to 20 mA.

CONTROL OUTPUT AND AUXILIARY OUTPUT

Control output

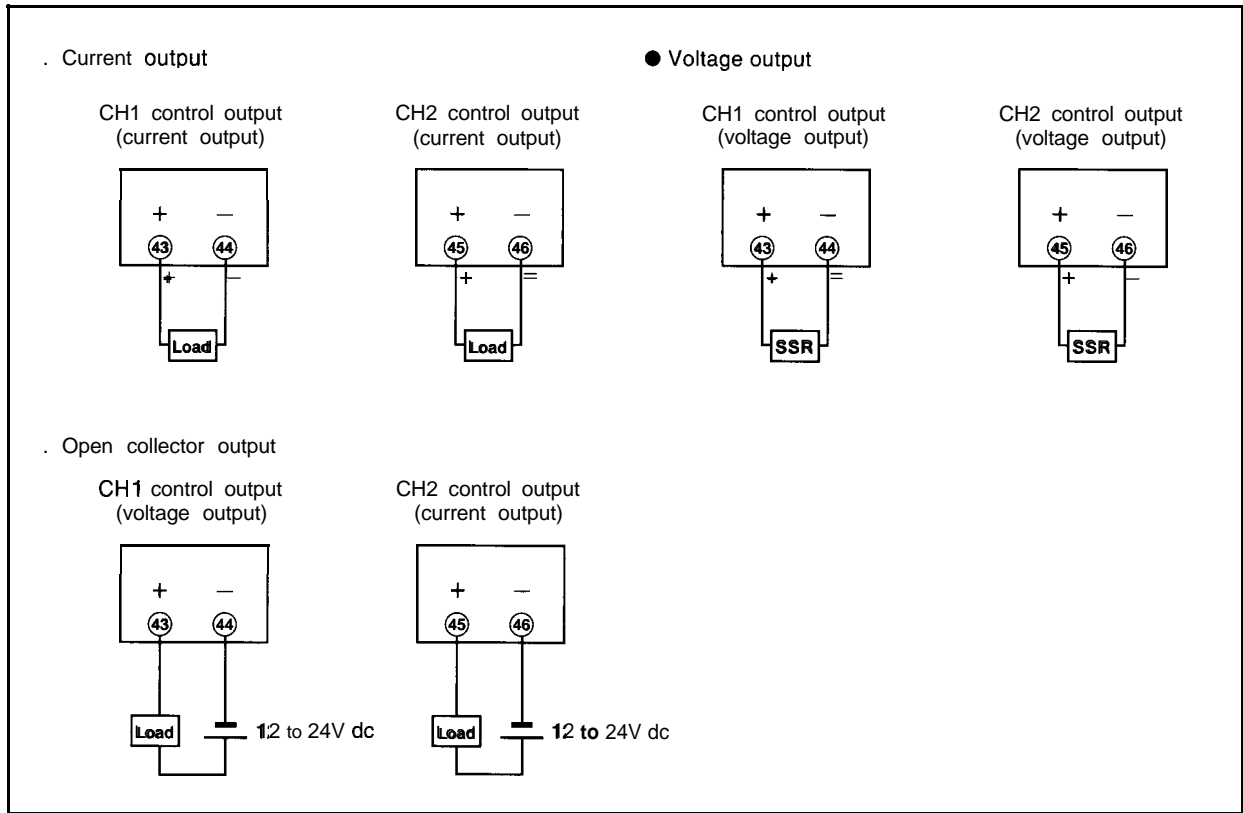

Auxiliary output

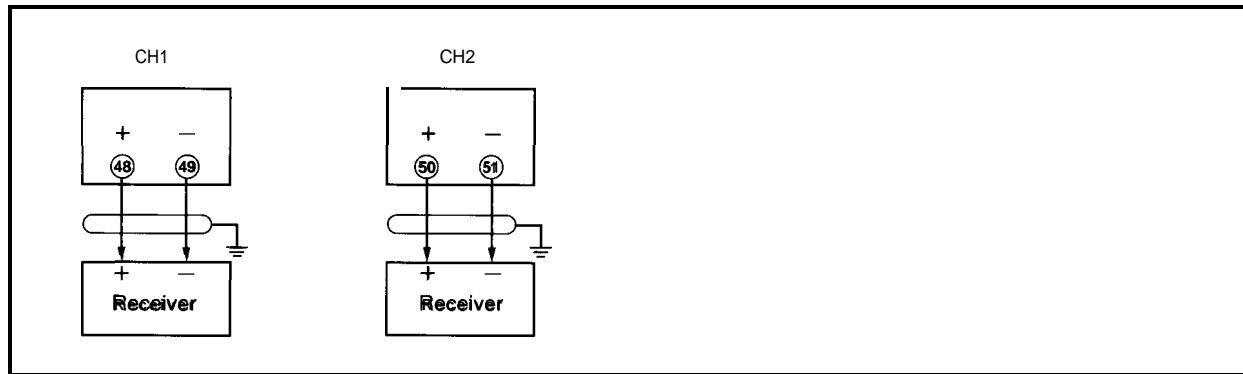

INTERNAL CIRCUIT OF EXTERNAL SWITCH INPUT

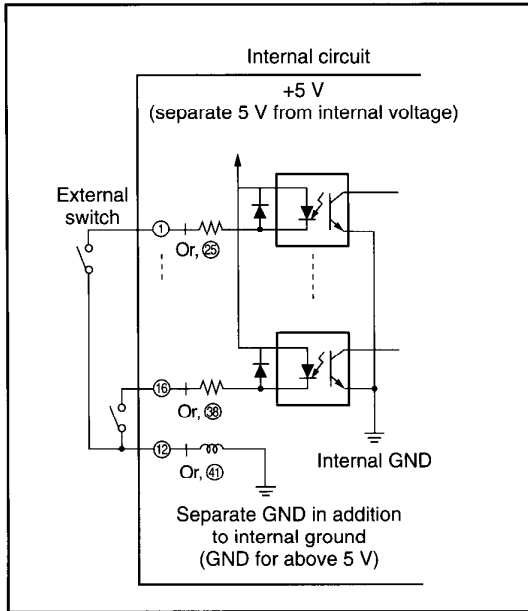

COMMUNICATIONS I/O (OPTION)

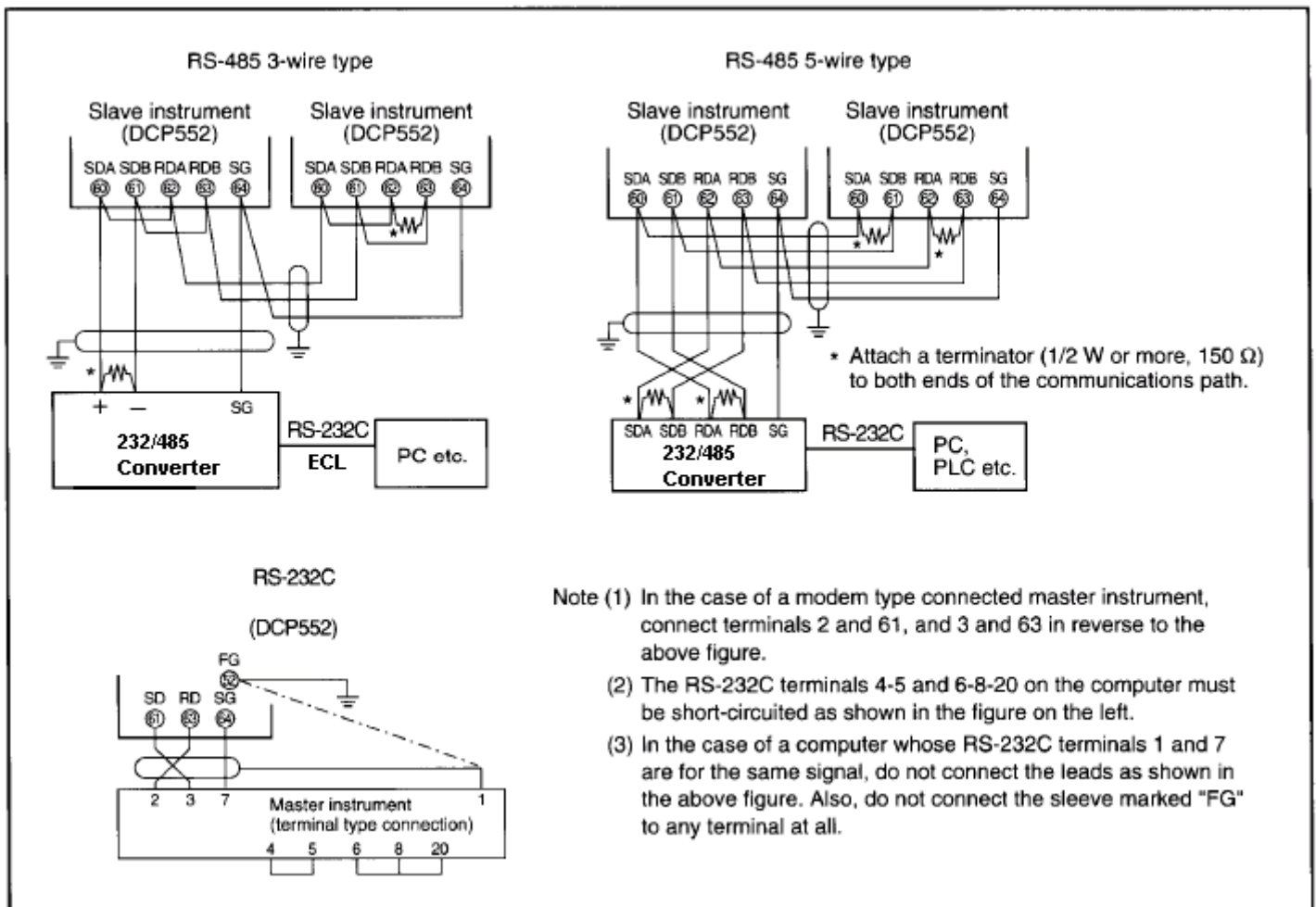

Note (1) In the case of a modem type connected master instrument, connect terminals 2 and 61, and 3 and 63 in reverse to the above figure.

(2) The RS-232C terminals 4-5 and 6-8-20 on the computer must be short-circuited as shown in the figure on the left.

(3) In the case of a computer whose RS-232C terminals 1 and 7 are for the same signal, do not connect the leads as shown in the above figure. Also, do not connect the sleeve marked "FG" to any terminal at all.

WIRING PRECAUTIONS

1. Isolating Inputs and Outputs Inside the Controller

Solid lines ——— show isolated items.
Dotted lines - - - - show non-isolated items.

PV input CH1	Digital circuit	Control output CH1
PV input CH2		Auxiliary output CH1
Loader communications		Control output CH2
External switch input		Auxiliary output CH2
Communications		
Memory card input		Event output

2. Noise Countermeasures for Instrument Power Supplies

(1) Reducing noise

Connect the DCP552 to a single-phase power supply for instruments, and take measures to prevent the influence of electrical noise.

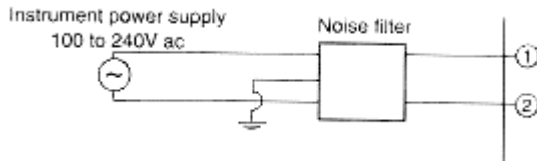

(2) When there is a lot of noise

If there is a lot of electrical noise, we recommend inserting an insulating transformer in the power circuit and using a line filter.

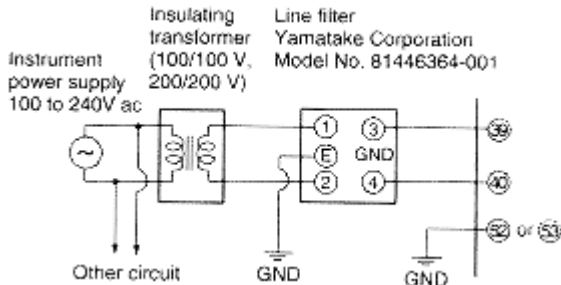

3. Noise Generating Sources and Countermeasures

Generally, the following generate electrical noise:

Relays and contacts, electromagnetic coils, solenoid valves, power lines (in particular, 90 Vac min.) induction loads, inverters, motor

WARRANTY / REMEDY

Honeywell warrants goods of its manufacture as being free of defective materials and faulty workmanship. Contact your local sales office for warranty information. If warranted goods are returned to Honeywell during the period of coverage, Honeywell will repair or replace without charge those items it finds defective. The foregoing is Buyer's sole remedy and is in lieu of all other warranties, expressed or implied, including those of merchantability

commutators, phase angle control SCR, radio communications equipment, welding equipment, high-voltage ignition equipment.

(1) Fast-rising noise

CR filters are effective in countering fast-rising noise.

Recommended CR filter:

Yamatake Corporation Model No. 81446365-001

(2) Noise with a high wave height

Varistors are effective in countering noise with a high wave height. However, note that the varistor may become short-circuited when trouble occurs. Pay attention to this when providing a varistor on a controller.

Recommended varistor:

Yamatake Corporation Model No. 81446366-001 (for 100 Vac)

81446367-001 (for 200 Vac)

4. Ground

Use only the FG terminal 52 or 53 on the DCP552 for grounding. Do not ground across other terminals. When it is difficult to ground shielded cable, prepare a separate GND terminal plate (earth bar).

Ground type: 100 Ω max.

Ground cable: 2 mm² min. annealed-copper wire (AWG14)

Cable length: Max. 20 m

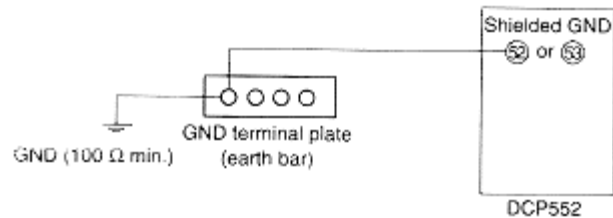

5. Precautions During Wiring

- After providing anti-noise measures, do not bundle primary and secondary power leads together, or pass them through the same piping or wiring duct.
- Maintain a distance of at least 50 cm between **I/O signal leads or communications leads** and the power lead. Also, do not pass these leads through the same piping or wiring duct.

6. Inspection After Wiring

After wiring is completed, be sure to inspect and check the wiring state. Wrong wiring may cause controller malfunction or accidents.

and fitness for a particular purpose. Specifications may change without notice. The information we supply is believed to be accurate and reliable as of this printing. However, we assume no responsibility for its use.

While we provide application assistance personally, through our literature and the Honeywell web site, it is up to the customer to determine the suitability of the product in the application.

Honeywell

Sensing and Control

Honeywell Inc.
11 West Spring Street
Freeport, IL 61032

www.honeywell.com/sensing